

# OPTOELECTRONICS HANDBOOK

---

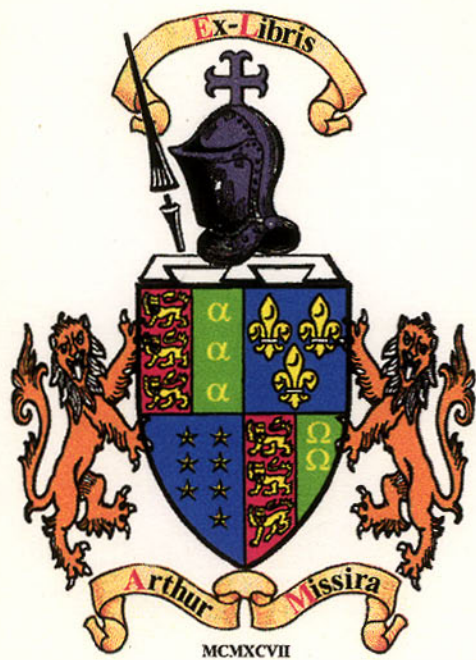
NATIONAL  
SEMICONDUCTOR



1979

OPTOELECTRONICS HANDBOOK

National Semiconductor

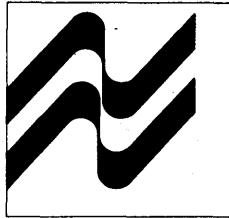


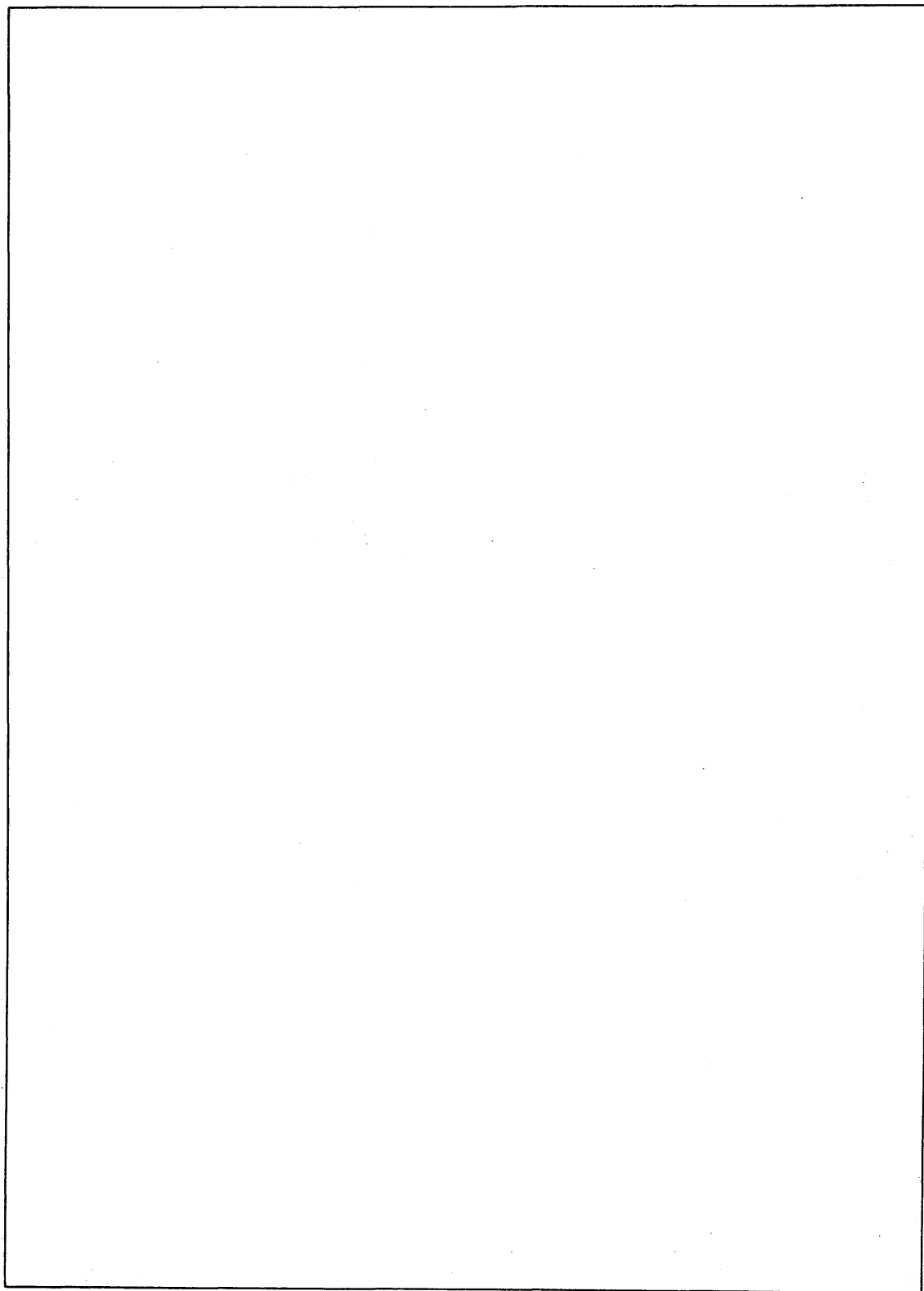
MCMXCVII

# OPTOELECTRONICS HANDBOOK

---

NATIONAL  
SEMICONDUCTOR





# Table of Contents

<b>Introduction</b> .....	1
 <b>Discrete LED Lamps</b>	
Introduction .....	3
Quick Selection Matrix .....	3
Lamp Selection Guide .....	4
LED Lamp Package Outlines .....	5
Mounting Techniques .....	7
LED Lamp Cross Reference .....	8
NSL4944 Current Regulated, Universal LED Lamp .....	12
NSL5020 Series Red LED Lamps .....	14
NSL5040 Series Red LED Lamps .....	16
NSL5050 Series Red LED Lamps .....	18
NSL5058 Red Diffused Lens LED Lamp .....	20
NSL5070 Series T-1 Size Red LED Lamps .....	22
NSL5080 T-1 Size Red LED Lamps .....	24
NSL5250 Series Green LED Lamps .....	26
NSL5274 T-1 Size Green LED Lamp .....	28
NSL5350 Series Yellow LED Lamps .....	29
NSL5374 T-1 Size Yellow LED Lamp .....	31
NSL5750 Series High Efficiency Red LED Lamps .....	32
NSL5774 T-1 Size High Efficiency Red LED Lamp .....	34
NSL52124 0.220" Green Rectangular Legend Lamp .....	35-1
NSL53124 0.220" Yellow Rectangular Legend Lamp .....	
NSL57124 0.220" High Efficiency Red Rectangular Legend Lamp .....	
NSL6050 Water-Clear Lens .....	35-3
NSL6051 Milk-White Diffused Lens .....	
NSL6052 Red Transparent Lens .....	
NSL6053 Light Red Diffused Lens .....	
NSL6055 Red Diffused Lens, Wide Viewing Angle .....	
NSL6056 Dark Red Diffused Lens .....	
NSL6152 Orange Emitter, Transparent Orange Lens .....	35-5
NSL6252 Green Emitter, Transparent Green Lens .....	
NSL6352 Yellow Emitter, Transparent Yellow Lens .....	
NSL6752 Orange-Red Emitter, Transparent Red Lens .....	
NSL6153 Orange Emitter — Diffused Orange Lens .....	35-7
NSL6154 Orange Emitter — Lightly Diffused Orange Lens .....	
NSL6253 Green Emitter — Diffused Green Lens .....	
NSL6254 Green Emitter — Lightly Diffused Green Lens .....	
NSL6353 Yellow Emitter — Diffused Yellow Lens .....	
NSL6354 Yellow Emitter — Lightly Diffused Yellow Lens .....	
NSL6753 Orange-Red Emitter — Diffused Red Lens .....	
NSL6754 Orange-Red Emitter — Lightly Diffused Red Lens .....	
MV5050 Water-Clear Lens .....	35-9
MV5051 Milk-White Diffused Lens .....	
MV5052 Red Transparent Lens .....	
MV5053 Light Red Diffused Lens .....	
MV5055 Red Diffused Lens, Wide Viewing Angle .....	

## Table of Contents (Continued)

MV5056 Dark Red Diffused Lens .....	
MV5152 Orange Emitter, Transparent Orange Lens .....	35-11
MV5252 Green Emitter, Transparent Green Lens .....	
MV5352 Yellow Emitter, Transparent Yellow Lens .....	
MV5752 Orange-Red Emitter, Transparent Red Lens .....	
MV5153 Orange Emitter — Diffused Orange Lens .....	35-13
MV5154 Orange Emitter — Lightly Diffused Orange Lens .....	
MV5253 Green Emitter — Diffused Green Lens .....	
MV5254 Green Emitter — Lightly Diffused Green Lens .....	
MV5353 Yellow Emitter — Diffused Yellow Lens .....	
MV5354 Yellow Emitter — Lightly Diffused Yellow Lens .....	
MV5753 Orange-Red Emitter — Diffused Red Lens .....	
MV5754 Orange-Red Emitter — Lightly Diffused Red Lens .....	
MV52124 0.220" Green Rectangular Legend Lamp .....	35-15
MV53124 0.220" Yellow Rectangular Legend Lamp .....	
MV57124 0.220" High Efficiency Red Rectangular Legend Lamp .....	
AN-153 Constant Current LED .....	37

### LED Numeric Arrays

Introduction .....	41
LED Numeric Array Selection Guide .....	42
LED Numeric Array Cross Reference .....	43
NSA0028, NSA0038 0.100 Inch (2.54 mm) LED Numeric Arrays .....	44
NSA500 Series 0.100 Inch (2.54 mm) LED Numeric Arrays .....	46
NSA1100 Series 0.100 Inch (2.54 mm) 9-Digit LED Numeric Arrays .....	50
NSA1298A 0.110 Inch (2.794 mm) 9-Digit LED Numeric Array .....	54
NSA1541A 0.140 Inch (3.556 mm) 4-Digit LED Numeric Array .....	56
NSA1588A 0.140 Inch (3.556 mm) 8-Digit LED Numeric Array .....	58
NSA5140A 0.110 Inch (2.79 mm) 14-Digit LED Numeric Array .....	60
NSA7120 0.110 Inch (2.794 mm) 12-Digit LED Numeric Array .....	62

### Multidigit LED Numeric Displays

Introduction .....	65
Multidigit LED Numeric Display Selection Guide .....	66
Multidigit LED Numeric Display Cross Reference .....	67
NSB5388 3 1/2-Digit 0.5 Inch (12.70 mm) DVM Display .....	68
NSB5415 4 1/2-Digit 0.5 Inch (12.70 mm) DVM Display .....	72
NSB5917, NSB5921, NSB5922 0.5 Inch (12.70 mm) 5 Digit Numeric Displays .....	75
NSB5918 3 3/4-Digit 0.5 Inch (12.70 mm) LED Display .....	77
NSB5931 0.5 Inch (12.70 mm) 6-Digit Common Cathode GaAsP Display .....	81
NSB7400, NSB7401, NSB7402, NSB7403, NSB7404, NSB7405 0.7 Inch 4-Digit LED Duplex Clock Displays .....	83
NSN3XX, NSB3XXX 0.3" Multidigit LED Numeric Display Series .....	87
NSN5XX, NSB5XXX 0.5" Multidigit LED Numeric Display Series .....	93
NSN7XX, NSB7XXX 0.7" Multidigit LED Numeric Display Series .....	99
AN-170 Mounting Techniques for Multidigit LED Numeric Displays .....	105

# Table of Contents (Continued)

## Integrated Displays

Introduction.....	111
NSM3914, NSM3915, NSM3916 End Stackable LED Bar Graph Array with Driver.....	112
NSM4000A LED Display with Driver.....	116

## Interface

User Guide-Array Drivers.....	121
User Guide-Display Drivers.....	121
ADD3501 3 1/2-Digit DVM with Multiplexed 7-Segment Output.....	122
ADD3701 3 3/4-Digit DVM with Multiplexed 7-Segment Output.....	123
CD4511BM/CD4511BC BCD-to-7-Segment Latch/Decoder/Driver.....	124
DM5446A/DM7446A, DM5447A/DM7447A, DM54LS47/DM74LS47, DM54LS48/DM74LS48, DM54LS49/DM74LS49 BCD/7-Segment Decoders/Drivers.....	125
DS75491 MOS-to-LED Quad Segment Driver.....	126
DS75492 MOS-to-LED Hex Digit Driver.....	126
DS55493/DS75493 Quad LED Segment Driver.....	127
DS8669 2-Digit BCD-to-7-Segment Decoder/Driver.....	128
DS8692, DS8693, DS8694 Printing Calculator Interface Set.....	129
DS7856/DS8856, DS8857, DS7858/DS8858 BCD-to-7-Segment LED Drivers.....	130
DS8859, DS8869 Open Collector Hex Latch LED Drivers.....	131
DS8861 MOS-to-LED 5-Segment Driver.....	132
DS8863 MOS-to-LED 8-Digit Driver.....	132
DS8867 8-Segment Constant Current Driver.....	133
DS8871, DS8872, DS8873, DS8920, DS8977 Saturating LED Cathode Drivers.....	134
DS8877 6-Digit LED Driver.....	135
DS8963 MOS-to-LED 8-Digit Driver.....	132
DS8973, DS8974, DS8975, DS8976, DS8978 9-Digit LED Drivers.....	136
LM3909 LED Flasher/Oscillator.....	137
LM3914 Dot/Bar Display Driver.....	138
LM3915 Dot/Bar Display Driver.....	139
MM5421, MM5422 Digital Alarm Clocks.....	140
MM5450, MM5451, LED Display Drivers.....	141
MM5455 Digital Alarm Clock.....	142
MM5456, MM5457, Digital Alarm Clocks.....	143
MM54C48/MM74C48 BCD-to-7-Segment Decoder.....	144
MM54C901/MM74C901 Hex Inverting TTL Buffer.....	145
MM54C902/MM74C902 Hex Non-Inverting TTL Buffer.....	145
MM54C903/MM74C903 Hex Inverting CMOS Buffer.....	145
MM54C904/MM74C904 Hex Non-Inverting TTL Buffer.....	145

# Alpha-Numerical Index

MV5050 Water-Clear Lens .....	35-9
MV5051 Milk-White Diffused Lens .....	
MV5052 Red Transparent Lens .....	
MV5053 Light Red Diffused Lens .....	
MV5055 Red Diffused Lens, Wide Viewing Angle .....	
MV5056 Dark Red Diffused Lens .....	
MV5152 Orange Emitter, Transparent Orange Lens .....	35-11
MV5153 Orange Emitter — Diffused Orange Lens .....	35-13
MV5154 Orange Emitter — Lightly Diffused Orange Lens .....	
MV5252 Green Emitter, Transparent Green Lens .....	35-11
MV5253 Green Emitter — Diffused Green Lens .....	35-13
MV5254 Green Emitter — Lightly Diffused Green Lens .....	
MV5352 Yellow Emitter, Transparent Yellow Lens .....	35-11
MV5353 Yellow Emitter — Diffused Yellow Lens .....	35-13
MV5354 Yellow Emitter — Lightly Diffused Yellow Lens .....	
MV5752 Orange-Red Emitter, Transparent Red Lens .....	35-11
MV5753 Orange-Red Emitter — Diffused Red Lens .....	35-13
MV5754 Orange-Red Emitter — Lightly Diffused Red Lens .....	
MV52124 0.220" Green Rectangular Legend Lamp .....	35-15
MV53124 0.220" Yellow Rectangular Legend Lamp .....	
MV57124 0.220" High Efficiency Red Rectangular Legend Lamp .....	
NSA0028 0.100 Inch (2.54 mm) LED Numeric Array .....	44
NSA0038 0.100 Inch (2.54 mm) LED Numeric Array .....	44
NSA500 Series 0.100 Inch (2.54 mm) LED Numeric Arrays .....	46
NSA598 0.100 Inch (2.54 mm) LED Numeric Array .....	46
NSA1100 Series 0.100 Inch (2.54 mm) 9-Digit LED Numeric Arrays .....	50
NSA1188 0.100 Inch (2.54 mm) LED Numeric Array .....	50
NSA1198 0.100 Inch (2.54 mm) LED Numeric Array .....	50
NSA1298A 0.110 Inch (2.794 mm) 9-Digit LED Numeric Array .....	54
NSA1541A 0.140 Inch (3.556 mm) 4-Digit LED Numeric Array .....	56
NSA1588A 0.140 Inch (3.556 mm) 8-Digit LED Numeric Array .....	58
NSA5140A 0.110 Inch (2.79 mm) 14-Digit LED Numeric Array .....	60
NSA7120 0.110 Inch (2.794 mm) 12-Digit LED Numeric Array .....	62
NSB3382 0.3" Multidigit LED Numeric Display .....	87
NSB3881 0.3" Multidigit LED Numeric Display .....	87
NSB3882 0.3" Multidigit LED Numeric Display .....	87
NSB5382 0.5" Multidigit LED Numeric Display .....	93
NSB5388 3 1/2-Digit 0.5 Inch (12.70 mm) LED Display .....	68
NSB5415 4 1/2-Digit 0.5 Inch (12.70 mm) LED Display .....	72
NSB5881 0.5" Multidigit LED Numeric Display .....	93
NSB5882 0.5" Multidigit LED Numeric Display .....	93
NSB5917 0.5 Inch (12.70 mm) 5 Digit Numeric Display .....	75
NSB5918 3 3/4-Digit 0.5 Inch (12.70 mm) LED Display .....	77
NSB5921 0.5 Inch (12.70 mm) 5-Digit Numeric Display .....	75
NSB5922 0.5 Inch (12.70 mm) 5-Digit Numeric Display .....	75
NSB5931 0.5 Inch (12.70 mm) 6-Digit Common Cathode GaAsP Display .....	81
NSB7400 0.7 Inch 4-Digit LED Duplex Clock Display .....	83
NSB7401 0.7 Inch 4-Digit LED Duplex Clock Display .....	83



# Alpha-Numerical Index (Continued)

NSB7402 0.7 Inch 4-Digit LED Duplex Clock Display.....	83
NSB7403 0.7 Inch 4-Digit LED Duplex Clock Display.....	83
NSB7404 0.7 Inch 4-Digit LED Duplex Clock Display.....	83
NSB7405 0.7 Inch 4-Digit LED Duplex Clock Display.....	83
NSC001 Mounting Clip for NSL5040 Series Lamps.....	7
NSC002 Clip and Ring for NSL5020 Series Lamps.....	7
NSC003 Clip and Ring for T1 3/4 Size Lamps.....	7
NSL4944 Current Regulated, Universal LED Lamp.....	12
NSL5020 Series Red LED Lamps.....	14
NSL5022 Red LED Lamp.....	14
NSL5023 Red LED Lamp.....	14
NSL5024 Red LED Lamp.....	14
NSL5026 Red LED Lamp.....	14
NSL5027 Red LED Lamp.....	14
NSL5040 Series Red LED Lamps.....	16
NSL5041 Red LED Lamp.....	16
NSL5042 Red LED Lamp.....	16
NSL5043 Red LED Lamp.....	16
NSL5046 Red LED Lamp.....	16
NSL5050 Series Red LED Lamps.....	18
NSL5052 Red LED Lamp.....	18
NSL5053 Red LED Lamp.....	18
NSL5056 Red LED Lamp.....	18
NSL5057 Red LED Lamp.....	18
NSL5058 Red Diffused Lens LED Lamp.....	20
NSL5070 Series T-1 Size Red LED Lamps.....	22
NSL5072A T-1 Size Red LED Lamp.....	22
NSL5076A T-1 Size Red LED Lamp.....	22
NSL5077A T-1 Size Red LED Lamp.....	22
NSL5080 Series T-1 Size Red LED Lamps.....	24
NSL5081 T-1 Size Red LED Lamp.....	24
NSL5082 T-1 Size Red LED Lamp.....	24
NSL5086 T-1 Size Red LED Lamp.....	24
NSL5250 Series Green LED Lamps.....	26
NSL5252A Green LED Lamp.....	26
NSL5253A Green LED Lamp.....	26
NSL5274 T-1 Size Green LED Lamp.....	28
NSL5350 Series Yellow LED Lamps.....	29
NSL5352A Yellow LED Lamp.....	29
NSL5353A Yellow LED Lamp.....	29
NSL5374 T-1 Size Yellow LED Lamp.....	31
NSL5750 Series High Efficiency Red LED Lamps.....	32
NSL5752 High Efficiency Red LED Lamp.....	32
NSL5753 High Efficiency Red LED Lamp.....	32
NSL5774 T-1 Size High Efficiency Red LED Lamp.....	34

# Alpha-Numerical Index of Interface Devices (Continued)

NSL6050 Water-Clear Lens .....	35-3
NSL6051 Milk-White Diffused Lens .....	
NSL6052 Red Transparent Lens .....	
NSL6053 Light Red Diffused Lens .....	
NSL6055 Red Diffused Lens, Wide Viewing Angle .....	
NSL6056 Dark Red Diffused Lens .....	
NSL6152 Orange Emitter, Transparent Orange Lens .....	35-5
NSL6153 Orange Emitter — Diffused Orange Lens .....	35-7
NSL6154 Orange Emitter — Lightly Diffused Orange Lens .....	
NSL6252 Green Emitter, Transparent Green Lens .....	35-5
NSL6253 Green Emitter — Diffused Green Lens .....	35-7
NSL6254 Green Emitter — Lightly Diffused Green Lens .....	
NSL6352 Yellow Emitter, Transparent Yellow Lens .....	35-5
NSL6353 Yellow Emitter — Diffused Yellow Lens .....	35-7
NSL6354 Yellow Emitter — Lightly Diffused Yellow Lens .....	
NSL6752 Orange-Red Emitter, Transparent Red Lens .....	35-5
NSL6753 Orange-Red Emitter — Diffused Red Lens .....	35-7
NSL6754 Orange-Red Emitter — Lightly Diffused Red Lens .....	
NSL52124 0.220" Green Rectangular Legend Lamp .....	35-1
NSL53124 0.220" Yellow Rectangular Legend Lamp .....	
NSL57124 0.220" High Efficiency Red Rectangular Legend Lamp .....	
NSM3914 .....	112
NSM3915 .....	112
NSM3916 .....	112
NSM4000A LED Display with Driver .....	116
NSN334 0.3" Multidigit LED Numeric Display .....	87
NSN373 0.3" Multidigit LED Numeric Display .....	87
NSN374 0.3" Multidigit LED Numeric Display .....	87
NSN381 0.3" Multidigit LED Numeric Display .....	87
NSN382 0.3" Multidigit LED Numeric Display .....	87
NSN534 0.5" Multidigit LED Numeric Display .....	93
NSN581 0.5" Multidigit LED Numeric Display .....	93
NSN582 0.5" Multidigit LED Numeric Display .....	93
NSN583 0.5" Multidigit LED Numeric Display .....	93
NSN584 0.5" Multidigit LED Numeric Display .....	93
NSN734 0.7" Multidigit LED Numeric Display .....	99
NSN781 0.7" Multidigit LED Numeric Display .....	99
NSN782 0.7" Multidigit LED Numeric Display .....	99
NSN783 0.7" Multidigit LED Numeric Display .....	99
NSN784 0.7" Multidigit LED Numeric Display .....	99

# Alpha-Numerical Index of Interface Devices

ADD3501 3 1/2-Digit DVM with Multiplexed 7-Segment Output.....	122
ADD3701 3 3/4-Digit DVM with Multiplexed 7-Segment Output.....	123
CD4511BC BCD-to-7-Segment Latch/Decoder/Driver.....	124
CD4511BM BCD-to-7-Segment Latch/Decoder/Driver.....	124
DM5446A BCD/7-Segment Decoder/Driver.....	125
DM5447A BCD/7-Segment Decoder/Driver.....	125
DM54LS47 BCD/7-Segment Decoder/Driver.....	125
DM54LS48 BCD/7-Segment Decoder/Driver.....	125
DM54LS49 BCD/7-Segment Decoder/Driver.....	125
DM7446A BCD/7-Segment Decoder/Driver.....	125
DM7447A BCD/7-Segment Decoder/Driver.....	125
DM74LS47 BCD/7-Segment Decoder/Driver.....	125
DM74LS48 BCD/7-Segment Decoder/Driver.....	125
DM74LS49 BCD/7-Segment Decoder/Driver.....	125
DS55493 Quad LED Segment Driver.....	127
DS75491 MOS-to-LED Quad Segment Driver.....	126
DS75492 MOS-to-LED Hex Digit Driver.....	126
DS75493 Quad LED Segment Driver.....	127
DS7856 BCD-to-7-Segment LED Driver.....	130
DS7858 BCD-to-7-Segment LED Driver.....	130
DS8669 2-Digit BCD-to-7-Segment Decoder/Driver.....	131
DS8692 Printing Calculator Interface Set.....	129
DS8693 Printing Calculator Interface Set.....	129
DS8694 Printing Calculator Interface Set.....	129
DS8856 BCD-to-7-Segment LED Driver.....	130
DS8857 BCD-to-7-Segment LED Driver.....	130
DS8858 BCD-to-7-Segment LED Driver.....	130
DS8859 Open Collector Hex Latch LED Driver.....	131
DS8861 MOS-to-LED 5-Segment Driver.....	132
DS8863 MOS-to-LED 8-Digit Driver.....	132
DS8867 8-Segment Constant Current Driver.....	133
DS8871 Saturating LED Cathode Driver.....	134
DS8872 Saturating LED Cathode Driver.....	134
DS8873 Saturating LED Cathode Driver.....	134
DS8920 Saturating LED Cathode Driver.....	134
DS8877 6-Digit LED Driver.....	134
DS8963 MOS-to-LED 8-Digit Driver.....	132
DS8973 9-Digit LED Driver.....	136
DS8974 9-Digit LED Driver.....	136
DS8975 9-Digit LED Driver.....	136
DS8976 9-Digit LED Driver.....	136
DS8978 9-Digit LED Driver.....	136

## Alpha-Numerical Index of Interface Devices (Continued)

LM3909 LED Flasher/Oscillator.....	137
LM3914 Dot/Bar Display Driver.....	138
LM3915 Dot/Bar Display Driver.....	139
MM5421 Digital Alarm Clock.....	140
MM5422 Digital Alarm Clock.....	140
MM5450 LED Display Driver.....	141
MM5451 LED Display Driver.....	141
MM5455 Digital Alarm Clock.....	142
MM5456 Digital Alarm Clock.....	143
MM5457 Digital Alarm Clock.....	143
MM54C48 BCD-to-7-Segment Decoder.....	144
MM54C901 Hex Inverting TTL Buffer.....	145
MM54C902 Hex Non-Inverting TTL Buffer.....	145
MM54C903 Hex Inverting CMOS Buffer.....	145
MM54C904 Hex Non-Inverting CMOS Buffer.....	145
MM74C48 BCD-to-7-Segment Decoder.....	145
MM74C901 Hex Inverting TTL Buffer.....	145
MM74C902 Hex Non-Inverting TTL Buffer.....	145
MM74C903 Hex Inverting CMOS Buffer.....	145
MM74C904 Hex Non-Inverting CMOS Buffer.....	145

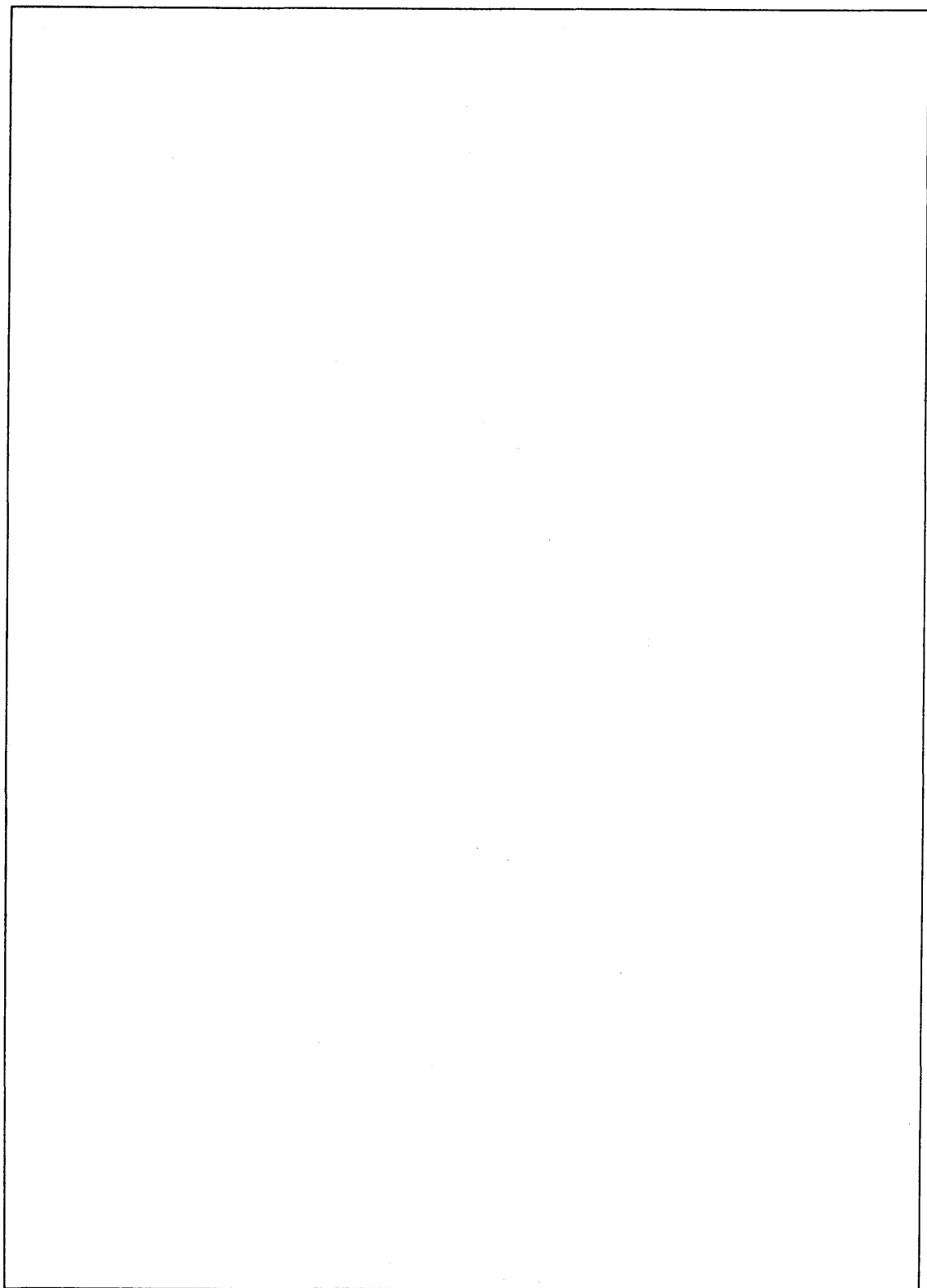


## **Introduction**

---

**Optoelectronics at National Semiconductor means visible light emitting diodes: discrete LED lamps, multidigit LED numeric arrays and displays, and various custom LED arrays and components.**

**National's broad line of LED devices offers the customer high quality, economical solutions to most design needs.**





## Discrete LED Lamps

National produces a broad line of discrete visible light emitting diodes which offer the customer a wide selection of packages, colors, lens effects, brightness and other characteristics for a multitude of applications. All LED lamps manufactured by National have the prefix NSL.

### QUICK SELECTION MATRIX

Lens	T1 Size	T1½ Size	Flangeless T1¼ Size	T1¼ Size	Rectangular
Water clear	NSL5080	NSL5020	NSL5040	NSL5050	
White diffused	NSL5081		NSL5041		
Red transparent	NSL5072A* NSL5082	NSL5022	NSL5042	NSL5052 NSL5752	
Red semi-diffused			NSL5043		
Light red diffused		NSL5024 NSL5027		NSL5057	
Red diffused	NSL5076A NSL5077A* NSL5086 NSL5774	NSL5023 NSL5026	NSL5046	NSL4944 NSL5053 NSL5056 NSL5058 NSL5753	NSL57124
Green transparent				NSL5252A	
Green diffused	NSL5274			NSL5253A	
Yellow transparent				NSL5352A	
Yellow diffused	NSL5374			NSL5353A	

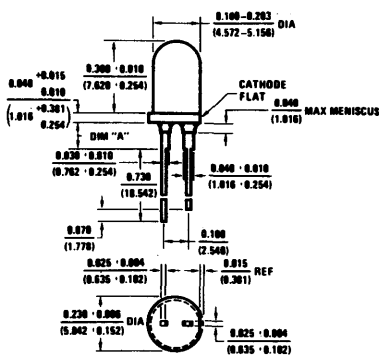
\*side viewing

# Lamp Selection Guide

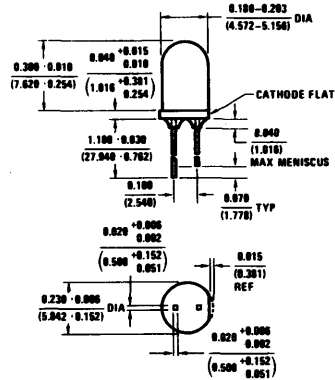
Device No.	Package Type	Color/Wavelength	Lens Type	Typical Luminous Intensity @20 mA	Viewing Angle off Axis	Typical Forward Voltage @20 mA	Mounting Hardware	Features	Data Sheet Page No.	Package Outline
NSL4944	Standard T1 1/2	Red/660 nm	red, diffused	0.8 mcd@25V	55	5V@13 mA	NSC003	Constant-current (10-18 mA)		A
NSL5020	T1 1/2	Red/660 nm	water clear	1.0 mcd	40	1.8	NSC002	Tapered lens		D
NSL5022	T1 1/2	Red/660 nm	red, transparent	1.0	40	1.8	NSC002	Tapered lens		D
NSL5023	T1 1/2	Red/660 nm	red, diffused	1.0	50	1.8	NSC002	Tapered lens		D
NSL5024	T1 1/2	Red/660 nm	light red, diffused	1.5	22	1.8	NSC002	Tapered lens		D
NSL5026	T1 1/2	Red/660 nm	red, diffused	1.5	30	1.8	NSC002	Tapered lens		D
NSL5027	T1 1/2	Red/660 nm	light red, diffused	8.0	15	1.8	NSC002	Tapered lens		D
NSL5040	T1 1/2, flangeless	Red/660 nm	water clear	1.0	60	1.8	NSC001	Special lens height (0.25")		C
NSL5041	T1 1/2, flangeless	Red/660 nm	white, diffused	1.5	50	1.8	NSC001	Special lens height (0.25")		C
NSL5042	T1 1/2, flangeless	Red/660 nm	red, transparent	1.0	60	1.8	NSC001	Special lens height (0.25")		C
NSL5043	T1 1/2, flangeless	Red/660 nm	red, semi-diffused	1.0	60	1.8	NSC001	Special lens height (0.25")		C
NSL5046	T1 1/2, flangeless	Red/660 nm	red, diffused	1.5	50	1.8	NSC001	Special lens height (0.25")		C
NSL5050	Standard T1 1/2	Red/660 nm	water clear	1.8	50	1.8	NSC003	—		A
NSL5052	Standard T1 1/2	Red/660 nm	red, transparent	1.3	50	1.8	NSC003	—		A
NSL5053	Standard T1 1/2	Red/660 nm	red, diffused	0.8	65	1.8	NSC003	—		A
NSL5056	Standard T1 1/2	Red/660 nm	red, diffused	1.3	55	1.8	NSC003	—		A
NSL5057	Standard T1 1/2	Red/660 nm	light red, diffused	2.0	10	1.8	NSC003	—		A
NSL5058	Standard T1 1/2	Red/660 nm	red, diffused	1.8	50	1.8	NSC003	One-inch leads		B
NSL5072A	Special T1	Red/660 nm	red, transparent	0.35	60	1.8	—	Side-view lamp		G
NSL5076A	Special T1	Red/660 nm	red, diffused	1.0	60	1.8	—	—		H
NSL5077A	Special T1	Red/660 nm	red, diffused	0.35	50	1.8	—	Side-view lamp		I
NSL5080	Standard T1	Red/660 nm	water clear	1.2	50	1.8	—	Small size		E
NSL5081	Standard T1	Red/660 nm	white, diffused	2.4	60	1.8	—	Small size		E
NSL5082	Standard T1	Red/660 nm	red, transparent	1.2	50	1.8	—	Small size		E
NSL5086	Standard T1	Red/660 nm	red, diffused	2.4	60	1.8	—	Small size		E
NSL5252A	Standard T1 1/2	Green/565 nm	green, transparent	15.0	15	2.2	NSC003	—		B
NSL5253A	Standard T1 1/2	Green/565 nm	green, diffused	1.5	30	2.2	NSC003	—		B
NSL5274	T1	Green/565 nm	green, diffused	1.0	45	2.2	—	—		F
NSL5352A	Standard T1 1/2	Yellow/585 nm	yellow, transparent	45.0	15	2.3	NSC003	—		B
NSL5353A	Standard T1 1/2	Yellow/585 nm	yellow, diffused	6.0	30	2.3	NSC003	—		B
NSL5374	T1	Yellow/585 nm	yellow, diffused	4.0	45	2.3	—	—		F
NSL5752	Standard T1 1/2	Red/635 nm	red, transparent	40.0	15	2.1	NSC003	High Efficiency Light Source		B
NSL5753	Standard T1 1/2	Red/635 nm	red, diffused	6.0	30	2.1	NSC003	High Efficiency Light Source		B
NSL5774	T1	Red/635 nm	red, diffused	5.0	45	2.1	—	High Efficiency Light Source		F
NSL5712A	Rectangular	Red/635 nm	red, diffused	4.0	55	2.1	—	Rectangular Lamp		J



# LED Lamp Package Outlines Inches (millimeters)

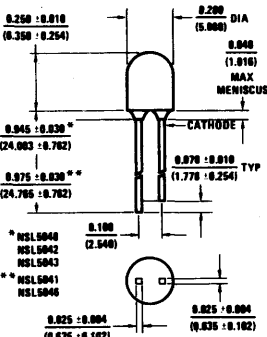


Package A

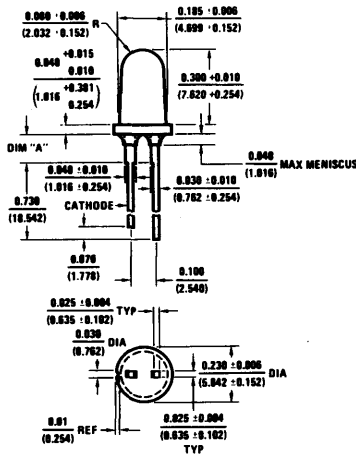


Package B

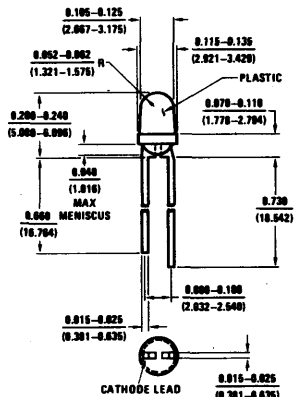
DIM "A"	LAMP TYPE
0.110 ± 0.015 (2.79 ± 0.38)	NSL5050, uncolored point source
0.110 ± 0.015 (2.79 ± 0.38)	NSL5052, red point source
0.110 ± 0.015 (2.79 ± 0.38)	NSL5053, red diffused
0.140 ± 0.015 (3.56 ± 0.38)	NSL5056, red diffused
0.195 ± 0.015 (4.95 ± 0.38)	NSL5057, light red high intensity diffused



Package C



Package D

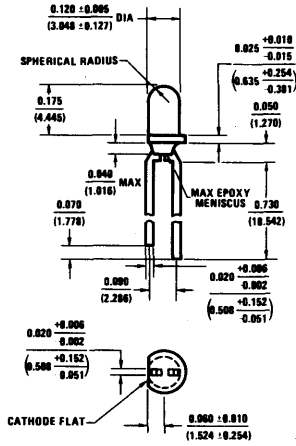


Package E

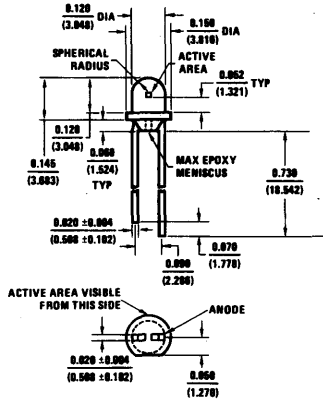
DIM "A"	LAMP TYPE
0.110 ± 0.015 (2.79 ± 0.38)	NSL5020, uncolored, transparent lens
0.110 ± 0.015 (2.79 ± 0.38)	NSL5022, red, transparent lens
0.110 ± 0.015 (2.79 ± 0.38)	NSL5023, red, diffused lens
0.140 ± 0.015 (3.56 ± 0.38)	NSL5024, light-red, diffused lens narrow angle
0.140 ± 0.015 (3.56 ± 0.38)	NSL5026, red, diffused lens narrow angle
0.195 ± 0.015 (4.95 ± 0.38)	NSL5027, red, diffused lens narrow angle

Note: ± 0.015(0.381) tolerance on all dimensions unless otherwise specified.

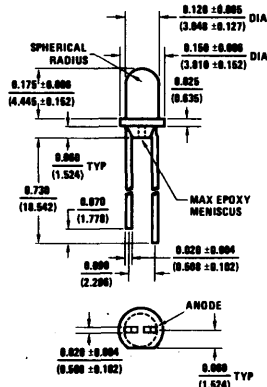
# LED Lamp Package Outlines (Continued) Inches (millimeters)



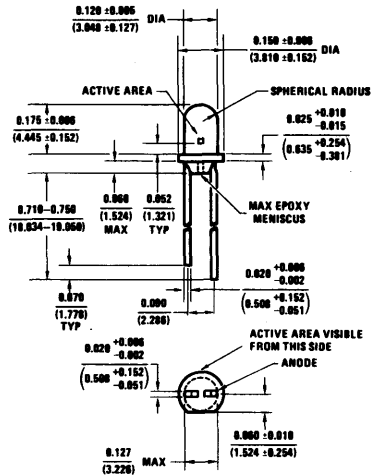
Package F



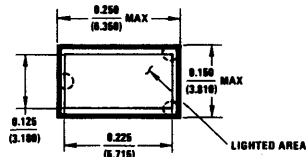
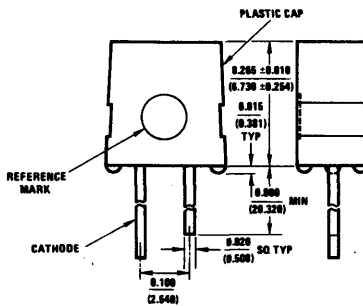
Package G



Package H



Package I

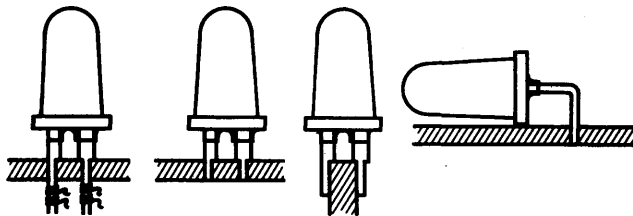


Package J

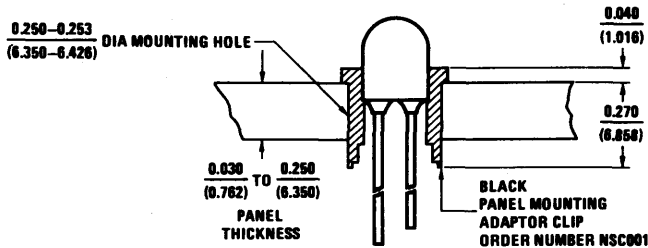
Note: ± 0.015(0.381) tolerance on all dimensions unless otherwise specified.

# Mounting Techniques

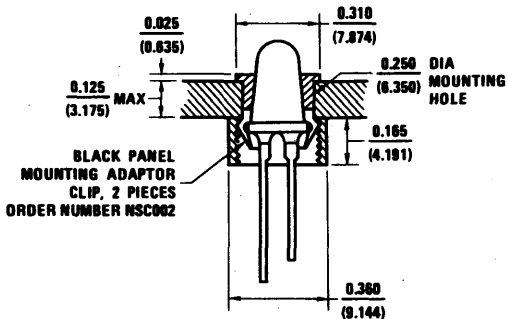
## P.C. Board Mounting



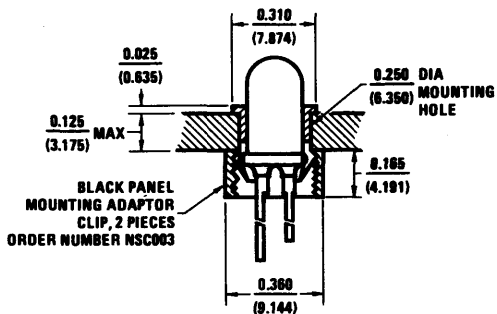
## Panel Mounting inches (millimeters)



NSC001 Clip



NSC002 Clip + Ring



NSC003 Clip + Ring

See individual data sheets for correct clip/lamp combination

## LED Lamp Cross Reference

Part Number	Description	NSC Device	Notes
<b>Hewlett-Packard</b>			
HLMP-1300	Red Diffused T1	NSL5774	B, C
HLMP-1301	Red Diffused T1	NSL5774	B, C
HLMP-1302	Red Diffused T1	NSL5774	B, C
HLMP-1400	Yellow Diffused T1	NSL5374	C
HLMP-1401	Yellow Diffused T1	NSL5374	C
HLMP-1402	Yellow Diffused T1	NSL5374	C
HLMP-1500	Green Diffused T1	NSL5274	B, C
HLMP-1501	Green Diffused T1	NSL5274	B, C
HLMP-1502	Green Diffused T1	NSL5274	B, C
5082-4403	Red Diffused T1 ¾	NSL5056	C
5082-4440	Red Diffused T1 ¾	NSL5056	C
5082-4480	Red Diffused T1	NSL5086	A
5082-4483	White Diffused Red T1	NSL5081	A
5082-4484	Red Diffused T1	NSL5086	A
5082-4486	Water Clear Red T1	NSL5080	A
5082-4487	Low Profile Water Clear Red T1	NSL5080	C
5082-4488	Low Profile Water Clear Red T1	NSL5080	C
5082-4494	Red Diffused T1	NSL5086	A
5082-4550	Yellow Diffused T1 ¾	NSL5353A	A
5082-4555	Yellow Diffused T1 ¾	NSL5353A	A
5082-4557	Yellow Transparent T1 ¾	NSL5352A	A
5082-4558	Yellow Transparent T1 ¾	NSL5352A	A
5082-4584	Yellow Diffused T1	NSL5374	C
5082-4650	Red Diffused T1 ¾	NSL5753	B
5082-4655	Red Diffused T1 ¾	NSL5753	B
5082-4657	Red Transparent T1 ¾	NSL5752	B
5082-4658	Red Transparent T1 ¾	NSL5752	B
5082-4684	Red Diffused T1	NSL5774	B, C
5082-4790	Low Profile Red Diffused T1 ¾	NSL5046	C
5082-4791	Low Profile Red Diffused T1 ¾	NSL5043	B, C
5082-4850	Red Diffused T1 ¾	NSL5053	A
5082-4855	Red Diffused T1 ¾	NSL5056	A
5082-4860	Red Current Regulating T1 ¾	NSL4944	B, C
5082-4880	Red Diffused T1 ¾	NSL5056	C
5082-4881	Red Diffused T1 ¾	NSL5057	C
5082-4882	Red Diffused T1 ¾	NSL5057	B, C
5082-4883	Water Clear Red T1 ¾	NSL5050	C
5082-4884	Water Clear Red T1 ¾	NSL5050	B, C
5082-4885	Water Clear Red T1 ¾	NSL5050	B, C

Notes: A—Direct replacement  
 B—Minor electrical or optical difference  
 C—Minor mechanical difference  
 D—Major electrical or optical difference  
 E—Major mechanical difference

## LED Lamp Cross Reference (Continued)

Part Number	Description	NSC Device	Notes
<b>Hewlett-Packard (Continued)</b>			
5082-4886	White Diffused Red T1 ¾	NSL5041	E
5082-4887	White Diffused Red T1 ¾	NSL5041	B, E
5082-4888	White Diffused Red T1 ¾	NSL5041	B, E
5082-4950	Green Diffused T1 ¾	NSL5253A	A
5082-4955	Green Diffused T1 ¾	NSL5253A	A
5082-4957	Green Transparent T1 ¾	NSL5252A	A
5082-4958	Green Transparent T1 ¾	NSL5252A	A
5082-4984	Green Diffused T1	NSL5274	B, C
<b>Monsanto</b>			
MV5020	Water Clear Red T1 ½	NSL5020	A
MV5022	Red Transparent T1 ½	NSL5022	A
MV5023	Red Diffused T1 ½	NSL5023	A
MV5024	Red Diffused T1 ½	NSL5024	A
MV5025	Red Diffused T1 ½	NSL5023	B
MV5026	Red Diffused T1 ½	NSL5026	A
MV5050	Water Clear Red T1 ¾	NSL5050	A
MV5052	Red Transparent T1 ¾	NSL5052	A
MV5053	Red Diffused T1 ¾	NSL5053	A
MV5054-1	Red Diffused T1 ¾	NSL5057	A
MV5054-2	Red Diffused T1 ¾	NSL5057	B
MV5054-3	Red Diffused T1 ¾	NSL5057	D
MV5055	Red Diffused T1 ¾	NSL5053	B, C
MV5056	Red Diffused T1 ¾	NSL5056	B, C
MV5074B	Red Diffused T1	NSL5086 or NSL5076A	C
MV5075B	Red Diffused T1	NSL5086 or NSL5076A	B, C
MV5077B	Low Profile Red Diffused T1	NSL5086	B, C
MV5252	Green Transparent T1 ¾	NSL5252A	A
MV5253	Green Diffused T1 ¾	NSL5253A	A
MV5254	Green Diffused T1 ¾	NSL5253A	B
MV5274B	Green Diffused T1	NSL5274	C
MV5352	Yellow Transparent T1 ¾	NSL5352A	A
MV5353	Yellow Diffused T1 ¾	NSL5353A	A
MV5354	Yellow Diffused T1 ¾	NSL5353A	B
MV5374B	Yellow Diffused T1	NSL5374	C
MV57124	Red Rectangular	NSL57124	A
MV5752	Red Transparent T1 ¾	NSL5752	A

Notes: A—Direct replacement  
 B—Minor electrical or optical difference  
 C—Minor mechanical difference  
 D—Major electrical or optical difference  
 E—Major mechanical difference

## LED Lamp Cross Reference (Continued)

Part Number	Description	NSC Device	Notes
<b>Monsanto (Continued)</b>			
MV5753	Red Diffused T1 ¼	NSL5753	A
MV5754	Red Diffused T1 ¼	NSL5753	B
MV5774B	Red Diffused T1	NSL5774	C
<b>Texas Instruments</b>			
TIL209A	Red Diffused T1	NSL5086 or NSL5076A	C
TIL211	Green Diffused T1	NSL5274	C
TIL213	Yellow Diffused T1	NSL5374	C
TIL220	Red Diffused T1 ¼	NSL5056	A
TIL221	Water Clear Red T1 ¼	NSL5050	A
TIL222	Green Diffused T1 ¼	NSL5253A	A
<b>Fairchild</b>			
FLV104A	Narrow Beam Red T1 ½	NSL5027	C, D
FLV110	Medium Profile Red Diffused T1 ¼	NSL5046	E
FLV111	Medium Profile Water Clear Red T1 ¼	NSL5040	E
FLV112	Medium Profile White Diffused Red T1 ¼	NSL5041	E
FLV117	Medium Profile Red Diffused T1 ¼	NSL5046	E
FLV118	Medium Profile Water Clear Red T1 ¼	NSL5040	E
FLV140	Low Profile Red Diffused T1 ¼	NSL5046	C
FLV141	Low Profile Red Transparent T1 ¼	NSL5042	C
FLV150	Red Diffused T1 ¼	NSL5056	C
FLV151	Red Transparent T1 ¼	NSL5052	C
FLV160	Red Diffused T1 ¼	NSL5057	A
FLV161	Red Transparent T1 ¼	NSL5052	A
FLV310	Medium Profile Green Diffused T1 ¼	NSL5253A	E
FLV311	Medium Profile Green Transparent T1 ¼	NSL5252A	E
FLV340	Low Profile Green Diffused T1 ¼	NSL5253A	E
FLV341	Low Profile Green Transparent T1 ¼	NSL5252A	E
FLV350	Green Diffused T1 ¼	NSL5253A	C
FLV351	Green Transparent T1 ¼	NSL5252A	C
FLV360	Green Diffused T1 ¼	NSL5253A	A
FLV361	Green Transparent T1 ¼	NSL5252A	A
FLV410	Medium Profile Yellow Diffused T1 ¼	NSL5353A	E
FLV411	Medium Profile Yellow Transparent T1 ¼	NSL5352A	E
FLV440	Low Profile Yellow Diffused T1 ¼	NSL5353A	E
FLV441	Low Profile Yellow Transparent T1 ¼	NSL5352A	E
FLV450	Yellow Diffused T1 ¼	NSL5353A	C

Notes: A—Direct replacement  
 B—Minor electrical or optical difference  
 C—Minor mechanical difference  
 D—Major electrical or optical difference  
 E—Major mechanical difference

## LED Lamp Cross Reference (Continued)

Part Number	Description	NSC Device	Notes
<b>Fairchild (Continued)</b>			
FLV451	Yellow Transparent T1 ¾	NSL5352A	C
FLV480	Yellow Diffused T1 ¾	NSL5353A	A
FLV461	Yellow Transparent T1 ¾	NSL5352A	A
FLV510	Medium Profile Red Diffused T1 ¾	NSL5753	E
FLV540	Low Profile Red Diffused T1 ¾	NSL5753	E
FLV550	Red Diffused T1 ¾	NSL5753	C
FLV560	Red Diffused T1 ¾	NSL5753	A
<b>Liteonix</b>			
GL4484	Green Diffused T1	NSL5274	C
GL4850	Green Diffused T1 ¾	NSL5253A	A
RLC200	Red Current Regulating T1 ¾	NSL4944	A
RLC201	Red Current Regulating T1 ¾	NSL4944	B
RL-20	Red Diffused T1 ¾	NSL5056	A
RL-20-02	Red Transparent T1 ¾	NSL5052	A
RL-20-04	Water Clear Red T1 ¾	NSL5050	A
RL-2000	Red Diffused T1 ¾	NSL5057	B
RL-209	Red Diffused T1	NSL5086	C
RL-209A	Red Diffused T1	NSL5086	C
RL-209-1	Red Diffused T1	NSL5086	B, C
RL-209-2	Red Diffused T1	NSL5086	C, D
RL-209-02	Red Transparent T1	NSL5082	C
RL-209-03	White Diffused Red T1	NSL5081	C
RL-209-04	Water Clear Red T1	NSL5080	C
RL-21	Red Diffused T1 ¾	NSL5056	A
RL-21-02	Red Transparent T1 ¾	NSL5052	A
RL-21-04	Water Clear Red T1 ¾	NSL5050	A
RL4403	Red Diffused T1 ¾	NSL5056	A
RL4480	Red Diffused T1	NSL5086	C
RL4480-1	Red Diffused T1	NSL5086	B, C
RL4480-2	Red Diffused T1	NSL5086	C, D
RL4480-5	Red Diffused T1	NSL5086	C
RL4484	Red Diffused T1	NSL5086	C
RL4850	Red Diffused T1 ¾	NSL5053	A
RL5054-1	Red Diffused T1 ¾	NSL5057	A
RL5054-2	Red Diffused T1 ¾	NSL5057	B
RL5054-5	Red Diffused T1 ¾	NSL5057	A
YL4484	Yellow Diffused T1	NSL5374	C
YL4850	Yellow Diffused T1 ¾	NSL5353A	A

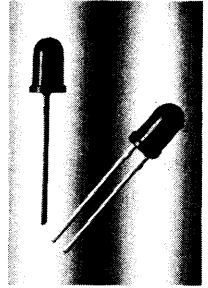
Notes: A—Direct replacement

B—Minor electrical or optical difference

C—Minor mechanical difference

D—Major electrical or optical difference

E—Major mechanical difference



# NSL4944 Current Regulated, Universal LED Lamp

## General Description

The NSL4944 lamp is a GaAsP red diffused solid-state high intensity LED encapsulated in a plastic package containing a current regulating IC that provides constant intensity over a wide voltage range. For applications information, see AN-153.

## Applications

- Indicator lamps for back-lit panels
- Optical coupling
- Front-viewed pilot lights
- Back-lit switches
- Annunciators
- AC indicator lamps
- Battery charging circuits

- 18V forward voltage
- 18V reverse voltage
- Very low turn-on voltage
- AC or DC operation
- Very wide useful voltage range
- Long life
- Wide angle view
- T1 3/4 size

## Features

- 2V startup
- No series resistor required

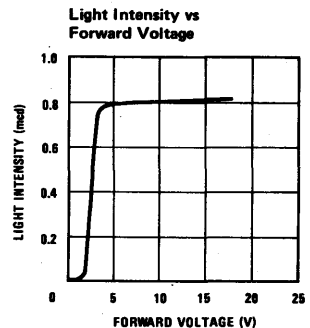
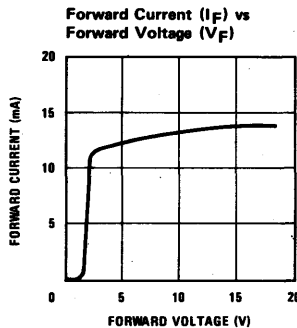
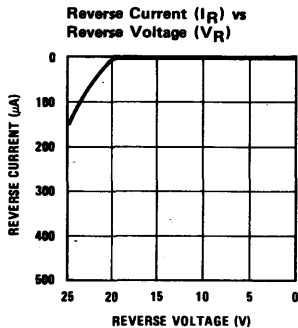
## Maximum Ratings

Forward Voltage @ 25°C	18V
Derate voltage linearly from 25°C	0.125V/°C
Reverse Voltage	18.0V
Power Dissipation @ 25°C	300 mW
Operating and Storage Temperature	-55 to +100°C
Lead Temperature (Soldering, 5 seconds)	260°C

## Electrical and Optical Characteristics (25°C)

PARAMETER	CONDITIONS	MIN	TYP	MAX	UNITS
Forward Current ( $I_F$ )	$2.4V \leq V_F \leq 18V$	10	13	18	mA
Light Intensity (I)	$V_F = 5V$	0.2	0.8		mcd
Reverse Breakdown Voltage ( $BV_R$ )	$I_R = 100\mu A$	18.0			V
Peak Wavelength ( $\lambda_{pk}$ )	$V_F = 10V$		660		nm
Spectral Width	$V_F = 10V$		40		nm
Angle of Half Intensity	$V_F = 10V$		55		degrees
Minimum Operational Voltage	$I_F = 10 mA$		1.9	2.4	V

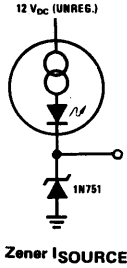
## Typical Performance Characteristics (25°C)



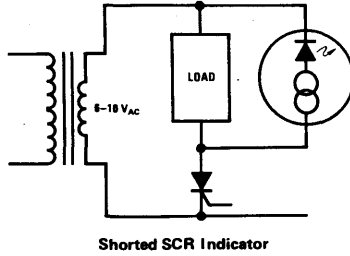


**Application Circuits** Note: Free indicator with every circuit.

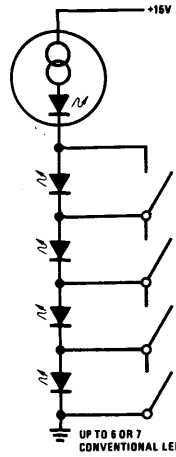
For complete application information, see AN-153.



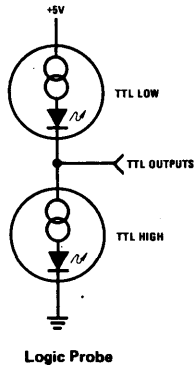
Zener ISOURCE



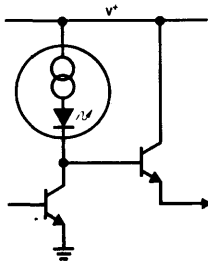
Shorted SCR Indicator



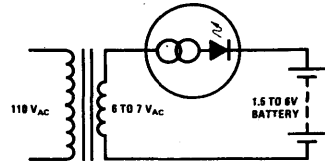
UP TO 6 OR 7 CONVENTIONAL LEDS  
Switch or Circuit Breaker or Relay Closure Indicator



Logic Probe



Replacing Amplifier Pull-up Resistor



Small Battery Trickle Charger

Order Number NSL4944 or NSL4944 + NSC003  
See Package Outline A Page 5



## NSL5020 Series Red LED Lamps

NSL5020 Uncolored, Transparent-Lens Red LED Lamp

NSL5022 Red, Transparent-Lens Red LED Lamp

NSL5023 Red, Diffused-Lens Red LED Lamp

NSL5024 Light-Red, Diffused-Lens Narrow Angle Red LED Lamp

NSL5026 Red, Diffused-Lens Narrow Angle Red LED Lamp

NSL5027 Light-Red, Diffused-Lens Narrow Angle Red LED Lamp

### General Description

The NSL5020 series lamps are GaAsP solid-state LEDs encapsulated in a plastic package. They are electrically identical but optically different owing to different lens designs. These devices may be panel mounted with plastic adaptor clip NSC002. They may be directly soldered into a printed circuit board or the leads may be wire-wrapped.

### Features

- High intensity
- Wide viewing angle
- Wire wrap or solder leads
- IC compatible
- T1 1/2 size

### Applications

- Pilot lights
- Indicator lights
- Non-visual, e.g., film annotation, optical coupling

### Absolute Maximum Ratings

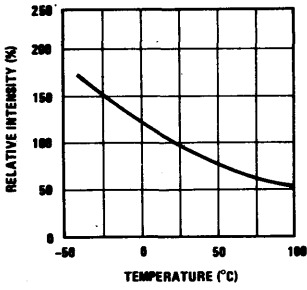
Forward Current, DC ( $I_F$ )	70 mA
Reverse Voltage	5.0V
Power Dissipation	
Derate 2.0 mW/°C above 25°C	180 mW
Operating and Storage	
Temperature Range	-55°C to +100°C
Lead Temperature	
(Soldering, 5 seconds)	260°C

### Electrical and Optical Characteristics (25°C)

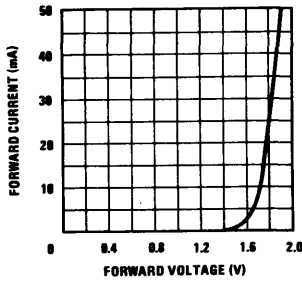
PARAMETER	CONDITIONS	5020	5022	5023	5024	5026	5027	UNITS
Forward Voltage ( $V_F$ )	$I_F = 20$ mA							
Typ		1.8	1.8	1.8	1.8	1.8	1.8	V
Max		2.0	2.0	2.0	2.0	2.0	2.0	V
Reverse Breakdown Voltage ( $BV_R$ )	100 $\mu$ A							
Min		5.0	5.0	5.0	5.0	5.0	5.0	V
Light Intensity (I)	$I_F = 20$ mA							
Min		0.5	0.5	0.5	0.5	0.5	4.0	mcd
Typ		1.0	1.0	1.0	1.5	1.5	8.0	mcd
Peak Wavelength	$I_F = 20$ mA							
Typ		660	660	660	660	660	660	nm
Spectral Width, Half-Intensity	$I_F = 20$ mA							
Typ		40	40	40	40	40	40	nm
Light Rise and Fall Time, 10%–90%	Step Change of $I_F$ , 50 $\Omega$ System							
Typ		50	50	50	50	50	50	ns
Angle of Half-Intensity Off Axis								
Typ		40	40	50	22	30	15	degrees
Capacitance	$V = 0$ , 1 MHz							
Typ		75	75	75	75	75	75	pF

**Typical Performance Characteristics**

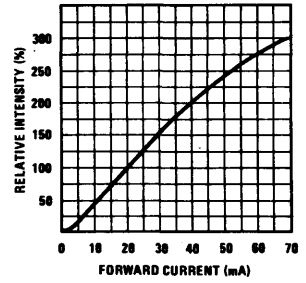
Light Intensity vs Ambient Temperature



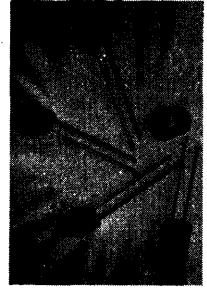
Forward Current (I<sub>F</sub>) vs Forward Voltage (V<sub>F</sub>)



Light Intensity vs Forward Current (I<sub>F</sub>)



Order Number NSL5020, NSL5023, NSL5024,  
NSL5026 or NSL5027  
See Package Outline D Page 5



## NSL5040 Series Red LED Lamps

NSL5040 Uncolored, Transparent-Lens Red LED Lamp

NSL5041 Uncolored, Diffused-Lens Red LED Lamp

NSL5042 Red, Transparent-Lens Red LED Lamp

NSL5043 Red, Semi-Diffused-Lens Red LED Lamp

NSL5046 Red, Diffused-Lens Narrow Angle Red LED Lamp

### General Description

The NSL5040 series lamps are T1 3/4 size GaAsP solid-state LEDs encapsulated in a plastic package. This series of lamps replaces the NSL100 series TO-106 lamps. They are electrically identical but optically different owing to different lens designs. These devices may be panel mounted with plastic adaptor clip NSC001. They may be directly soldered into a printed circuit board or the leads may be wire wrapped.

### Maximum Ratings

Forward Current, DC ( $I_F$ )	70 mA
Reverse Voltage	5.0V
Power Dissipation	180 mW
Derate 2.0 mW/°C above 25°C	
Operating and Storage Temperature Range	-55°C to +100°C
Lead Temperature (Soldering, 5 seconds)	260°C

### Applications

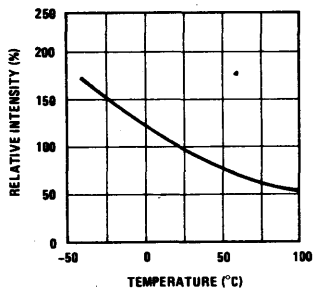
- Pilot lights
- Indicator lights
- Non-visual, e.g., film annotation, optical coupling

### Electrical and Optical Characteristics (25°C)

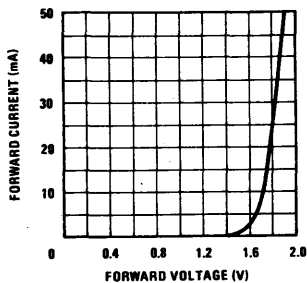
PARAMETER	CONDITIONS	5040	5041	5042	5043	5046	UNITS
Forward Voltage ( $V_F$ )	$I_F = 20$ mA						
Typ		1.8	1.8	1.8	1.8	1.8	V
Max		2.0	2.0	2.0	2.0	2.0	V
Reverse Breakdown Voltage ( $BV_R$ )	100 $\mu$ A						
Min		5.0	5.0	5.0	5.0	5.0	V
Light Intensity (I)	$I_F = 20$ mA						
Min		0.5	0.5	0.5	0.5	0.5	mcd
Typ		1.0	1.0	1.0	1.5	1.5	mcd
Peak Wavelength	$I_F = 20$ mA						
Typ		660	660	660	660	660	nm
Spectral Width, Half-Intensity	$I_F = 20$ mA						
Typ		40	40	40	40	40	nm
Light Rise and Fall Time, 10%–90%	Step Change of $I_F$ , $I_F$ , 50 $\Omega$ System						
Typ		50	50	50	50	50	ns
Angle of Half-Intensity Off Axis							
Typ		60	50	60	60	50	degrees
Capacitance							
Typ	V = 0, 1 MHz	75	75	75	75	75	pF

**Performance Characteristics Curves**

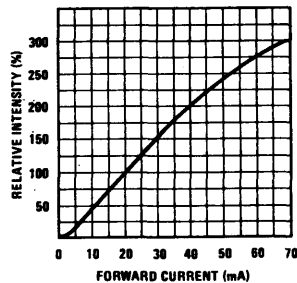
**Light Intensity vs Ambient Temperature**



**Forward Current ( $I_f$ ) vs Forward Voltage ( $V_f$ )**



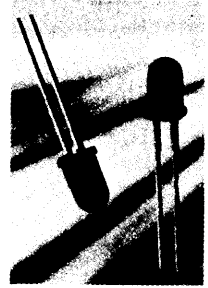
**Light Intensity vs Forward Current ( $I_f$ )**



**Order Number:**

LAMP	LAMP WITH MOUNTING CLIP
NSL5040	NSL5040 + NSC001
NSL5041	NSL5041 + NSC001
NSL5042	NSL5042 + NSC001
NSL5043	NSL5043 + NSC001
NSL5046	NSL5046 + NSC001

See Package Outline C Page 5



## NSL5050 Series Red LED Lamps

NSL5050 Uncolored, Transparent-Lens Red LED Lamp

NSL5052 Red, Transparent-Lens Red LED Lamp

NSL5053 Red, Diffused-Lens Wide Angle Red LED Lamp

NSL5056 Red, Diffused-Lens Red LED Lamp

NSL5057 Light-Red, Diffused-Lens Narrow Angle Red LED Lamp

### General Description

The NSL5050 series lamps are GaAsP solid-state LEDs encapsulated in a plastic package. They are electrically identical but optically different owing to different lens designs. These devices may be panel mounted with plastic adaptor clip NSC003. They may be directly soldered into a printed circuit board or the leads, available in two lengths, may be wire-wrapped. See physical dimensions drawing.

### Absolute Maximum Ratings

Forward Current, DC ( $I_F$ )	70 mA
Reverse Voltage	5.0V
Power Dissipation	
Derate 2.0 mW/°C above 25°C	180 mW
Operating and Storage	
Temperature Range	-55°C to +100°C
Lead Temperature	
(Soldering, 5 seconds)	260°C

### Applications

- Indicator lamps for back-lit panels
- Optical coupling
- Front-viewed pilot lights
- Back lit switches
- Enunciators

### Features

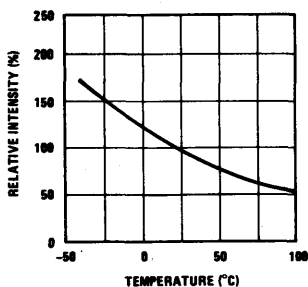
- High intensity
- Wide viewing angle
- Wire-wrap or solder leads
- IC compatible
- T1 3/4 size

### Electrical and Optical Characteristics (25°C)

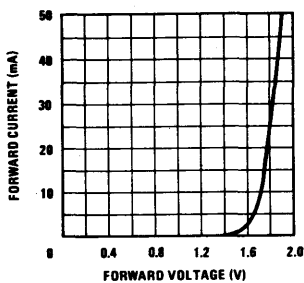
PARAMETER	CONDITIONS	5050	5052	5053	5056	5057	UNITS	
Forward Voltage ( $V_F$ )	$I_F = 20$ mA	Typ	1.8	1.8	1.8	1.8	V	
Max.		2.0	2.0	2.0	2.0	2.0	V	
Reverse Breakdown Voltage ( $BV_R$ )	100 $\mu$ A	Min	5.0	5.0	5.0	5.0	V	
Light Intensity (I)		$I_F = 20$ mA	Typ	1.8	1.3	0.8	1.3	2.0
Min.	0.5		0.5	0.5	0.5	0.5	0.5	mcd
Peak Wavelength	$I_F = 20$ mA	Typ	660	660	660	660	660	nm
Spectral Width, Half-Intensity		$I_F = 20$ mA	Typ	40	40	40	40	40
Light Rise and Fall Time, 10%–90%	Step Change of $I_F$ , 50 $\Omega$ System		Typ	50	50	50	50	50
Angle of Half-Intensity Off Axis		Typ	50	50	65	55	10	degrees
Capacitance	V = 0, 1 MHz		Typ.	75	75	75	75	75

# Typical Performance Characteristics

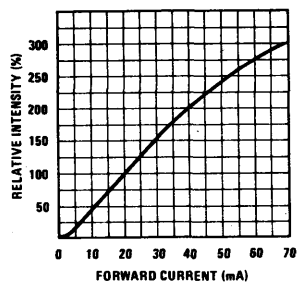
Light Intensity vs Ambient Temperature



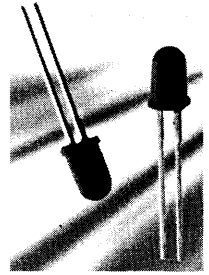
Forward Current ( $I_F$ ) vs Forward Voltage ( $V_F$ )



Light Intensity vs Forward Current ( $I_F$ )



Order Number NSL5050, NSL5052, NSL5053,  
 NSL5056 or NSL5057  
 Lamp with Mounting Clip:  
 NSL505X + NSC003  
 See Package Outline A Page 5



## NSL5058 Red Diffused Lens LED Lamp

### General Description

The NSL5058 lamps are GaAsP solid-state LEDs encapsulated in a plastic package featuring a one inch lead length. These devices may be panel mounted with plastic adaptor clip NSC003. They may be directly soldered into a printed circuit board or the leads may be wire-wrapped. See physical dimensions drawing.

### Features

- One inch lead length
- High intensity
- Wide viewing angle
- Wire-wrap or solder leads
- IC compatible
- T1 3/4 size

### Absolute Maximum Ratings

Forward Current, DC ( $I_F$ )	70 mA
Reverse Voltage	5.0V
Power Dissipation	
Derate 2.0 mW/°C above 25°C	180 mW
Operating and Storage	
Temperature Range	-40°C to +100°C
Lead Temperature	
(Soldering, 5 seconds)	260°C

### Applications

- Indicator lamps for back-lit panels
- Optical coupling
- Front-viewed pilot lights
- Back lit switches
- Annunciators

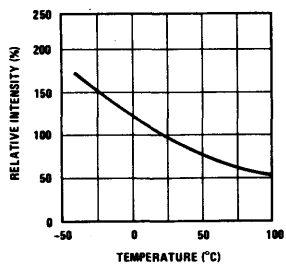
### Electrical and Optical Characteristics (25°C)

PARAMETER	CONDITIONS	MIN	TYP	MAX	UNITS
Forward Voltage ( $V_F$ )	$I_F = 20 \text{ mA}$		1.8	2.0	V
Reverse Breakdown Voltage ( $BV_R$ )	$100 \mu\text{A}$	5.0			V
Light Intensity (I)	$I_F = 20 \text{ mA}$	0.5	1.8		mcd
Peak Wavelength	$I_F = 20 \text{ mA}$		660		nm
Spectral Width, Half-Intensity	$I_F = 20 \text{ mA}$		40		nm
Light Rise and Fall Time, 10%–90%	Step Change of $I_F$ , 50Ω System		50		ns
Angle of Half-Intensity Off Axis			50		degrees
Capacitance	$V = 0$ , 1 MHz		75		pF

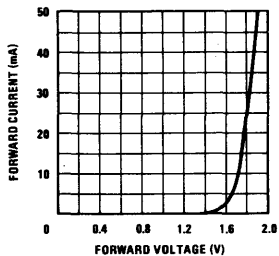


# Typical Performance Characteristics

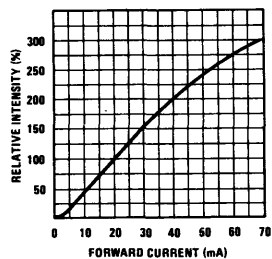
Light Intensity vs Ambient Temperature



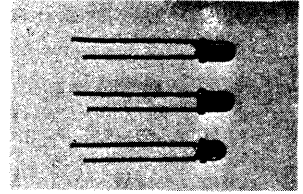
Forward Current ( $I_F$ ) vs Forward Voltage ( $V_F$ )



Light Intensity vs Forward Current ( $I_F$ )



Order Number: Lamp with Mounting Clip  
 NSL5058 + NSC003  
 See Package Outline B Page 5



## NSL5070 Series T-1 Size Red LED Lamps

NSL5072A Side View, Red Transparent-Lens

NSL5076A Red Diffused-Lens

NSL5077A Side View, Red Diffused-Lens

### General Description

This special purpose series of GaAsP lamps are designed to satisfy your particular design requirement where either side viewing or extra lens height is needed. The NSL5072A is a small side view lamp while the NSL5076A retains all the characteristics of a standard T1 size lamp, except for a higher lens height. The NSL5077A combines these 2 features in a single lamp—side view plus extra lens height. Wide viewing angle and good ON-OFF contrast characterize these small lamps.

- Computers
- Indicator lamps
- Pilot lamps
- Circuit status
- Mobile and portable equipment
- Vending machines
- Test equipment
- Medical instruments

### Features

- Wide viewing angle
- Wire wrap or solder leads
- IC compatible
- Reliable and rugged
- Low power consumption
- Long life

### Applications

- Appliances
- Cameras

### Absolute Maximum Ratings

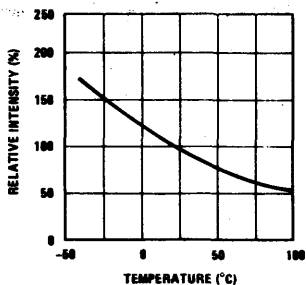
DC Forward Current	50 mA
Reverse Voltage	5.0V
Power Dissipation	100 mW
Derate Linearly 1.0 mW/°C above 25°C	
Peak Forward Current	1A
1 $\mu$ s Pulse, 300 pps	
Operating and Storage Temperature Range	-55°C to +100°C
85/85 Temp.—Humidity	1.27 mW/°C
Lead Temperature (Soldering)	230°C for 5 sec.

### Electrical and Optical Characteristics (25°C)

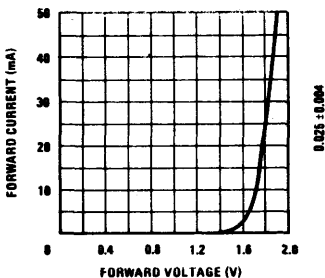
PARAMETER	CONDITIONS	5072A	5076A	5077A	UNITS
Forward Voltage (V <sub>F</sub> )	I <sub>F</sub> = 20 mA				
Typ		1.8	1.8	1.8	V
Max		2.0	2.0	2.0	V
Reverse Breakdown Voltage (BV <sub>R</sub> )	I <sub>R</sub> = 100 $\mu$ A				
Min		5.0	5.0	5.0	V
Light Intensity (I)	I <sub>F</sub> = 20 mA				
Typ		0.35	1.0	0.35	mcd
Min		0.15	0.15	0.15	mcd
Peak Wavelength	I <sub>F</sub> = 20 mA	660	660	660	nm
Spectral Width, Half-Intensity	I <sub>F</sub> = 20 mA				
Typ		40	40	40	nm
Light Rise and Fall Time, 10–90%	50 $\Omega$ Sys				
Typ		50	50	50	ns
Angle of Half-Intensity Off Axis	I <sub>F</sub> = 20 mA				
Typ		60	60	50	degrees
Capacitance	V = 0, 1 MHz				
Typ		75	75	75	pF

**Performance Characteristics Curves**

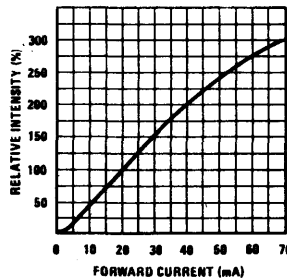
**Light Intensity vs Ambient Temperature**



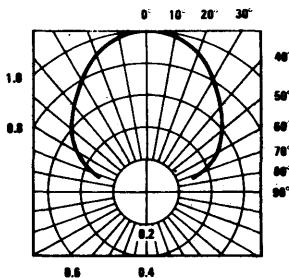
**Forward Current ( $I_F$ ) vs Forward Voltage ( $V_F$ )**



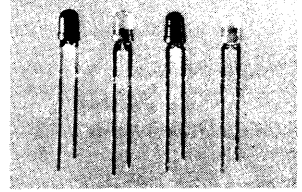
**Light Intensity vs Forward Current ( $I_F$ )**



**Relative Luminous Intensity vs Angular Displacement  
NSL5076A**



Order Number NSL5072A  
 See Package Outline G Page 6  
 Order Number NSL5076A  
 See Package Outline H Page 6  
 Order Number NSL5077A  
 See Package Outline I Page 6



## NSL5080 Series T-1 Size Red LED Lamps

NSL5080 Uncolored Transparent-Lens

NSL5081 Uncolored Diffused-Lens

NSL5082 Red Transparent-Lens

NSL5086 Red Diffused-Lens

### General Description

The T-1 size (0.125 dia) series lamps are GaAsP, solid state LEDs encapsulated in a plastic package. They are electrically identical but optically different owing to different lens design. The lens configuration is designed for applications where space is a premium. High axial luminous intensity with a wide viewing angle and good ON-OFF contrast characterize these small lamps.

### Applications

- Appliances
- Cameras
- Computers
- Indicator lamps
- Pilot lamps
- Circuit status
- Mobile and portable equipment
- High density arrays
- Vending machines
- Test equipment
- Medical instruments

### Features

- Wide viewing angle
- Wire wrap or solder leads
- IC compatible
- Reliable and rugged
- Low power consumption
- Long life
- Mount on 0.125 centers

### Absolute Maximum Ratings

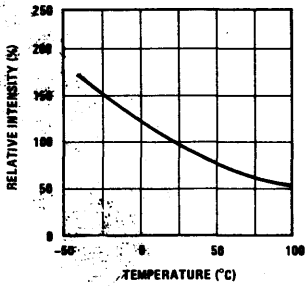
DC Forward Current	50 mA
Reverse Voltage	5.0V
Power Dissipation	100 mW
Derate Linearly 1.0 mW/°C above 25°C	
Peak Forward Current	1A
1 μs pulse, 300 pps	
Operating and Storage Temperature	
Range	-55°C to +100°C
85/85 Temp. — Humidity	1000 hrs
Lead Temperature (Soldering)	230°C for 5 sec

### Electrical and Optical Characteristics (25°C)

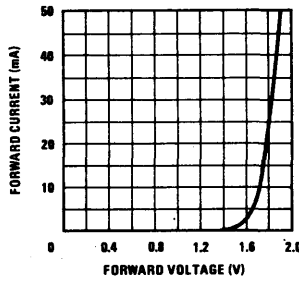
PARAMETER	CONDITIONS	5080	5081	5082	5086	UNITS
Forward Voltage (V <sub>F</sub> )	I <sub>F</sub> = 20 mA					
Typ		1.8	1.8	1.8	1.8	V
Max		2.0	2.0	2.0	2.0	V
Reverse Breakdown Voltage (BV <sub>R</sub> )	I <sub>R</sub> = 100 μA					
Min		5.0	5.0	5.0	5.0	V
Light Intensity (I)	I <sub>F</sub> = 20 mA					
Typ		1.2	2.4	1.2	2.4	mcd
Min		0.3	0.3	0.3	0.3	mcd
Peak Wavelength	I <sub>F</sub> = 20 mA					
Typ		660	660	660	660	nm
Spectral Width, Half-Intensity	I <sub>F</sub> = 20 mA					
Typ		40	40	40	40	nm
Light Rise and Fall Time, 10–90%	50Ω Sys.					
Typ		50	50	50	50	ns
Angle of Half-Intensity Off Axis	I <sub>F</sub> = 20 mA					
Typ		50	60	50	60	degrees
Capacitance	V = 0, 1 MHz					
Typ		75	75	75	75	pF

# Performance Characteristics Curves

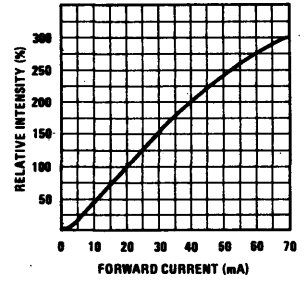
Light Intensity vs Ambient Temperature



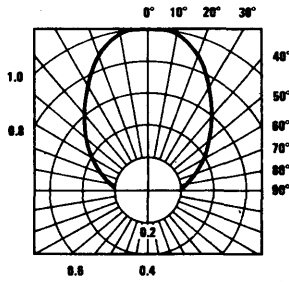
Forward Current ( $I_F$ ) vs Forward Voltage ( $V_F$ )



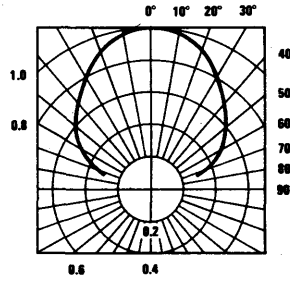
Light Intensity vs Forward Current ( $I_F$ )



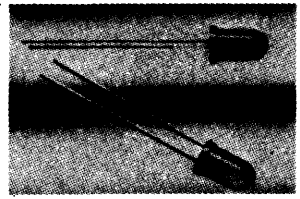
Relative Luminous Intensity vs Angular Displacement  
NSL5080, NSL5082



Relative Luminous Intensity vs Angular Displacement  
NSL5081, NSL5086



Order Number NSL5080  
See Package Outline E Page 5



## NSL5250 Series Green LED Lamps

NSL5252A Green, Transparent-Lens LED Lamp

NSL5253A Green, Diffused-Lens LED Lamp

### General Description

These T1 3/4 size [0.200 inch (5 mm) dia] lamps are solid state LED's, encapsulated in an epoxy package. They are electrically similar but optically different owing to different lens configuration. These devices may be panel mounted with a plastic adaptor clip, directly soldered into a printed circuit board or the leads may be wire-wrapped.

### Applications

- Pilot lights
- Indicator lights
- GO-NO GO indicators
- Test equipment
- Computers
- Appliances

### Features

- High intensity
- Wide viewing angle
- Wire wrap or solder leads
- IC compatible
- Low power consumption

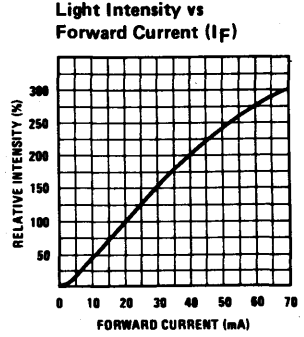
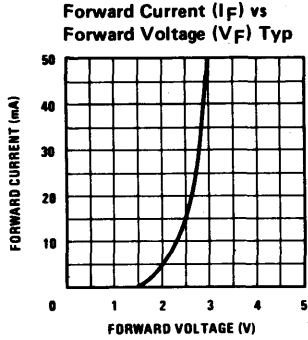
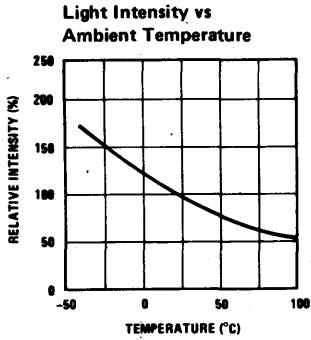
### Absolute Maximum Ratings

Forward Current, DC ( $I_F$ )	35 mA
Reverse Voltage	5.0V
Power Dissipation	105 mW
Derate linearly 1.14 mW/°C above 25°C	
Peak Forward Current	1A
1 $\mu$ s pulse, 300 pps	
Operating and Storage Temperature	
Range	-55°C to +100°C
Lead Temperature (Soldering)	260°C for 5 sec

### Electrical and Optical Characteristics (25°C)

PARAMETER	CONDITIONS	NSL5252A	NSL5253A	UNITS
Forward Voltage ( $V_F$ )	$I_F = 20$ mA			
Typ		2.2	2.2	V
Max		3.0	3.0	V
Reverse Breakdown Voltage ( $BV_R$ )	$I_R = 100$ $\mu$ A			
Min		5.0	5.0	V
Luminous Intensity (I)	$I_F = 20$ mA			
Min		2.0	0.8	mcd
Typ		15.0	1.5	mcd
Peak Wavelength	$I_F = 20$ mA			
Typ		565	565	nm
Spectral Width	$I_F = 20$ mA			
Typ		40	40	nm
Light Rise and Fall Time 10-90%	Step Change of $I_F$			
Typ	50 $\Omega$ System	50	50	ns
Angle of Half-Intensity Off Axis	$I_F = 20$ mA			
Typ		15	30	degrees
Capacitance	$V_F = 0,1$ MHz			
Typ		75	75	pF

Typical Performance Characteristics



Order Number:

LAMP	LAMP WITH MOUNTING CLIP
NSL5252A	NSL5252A + NSC003
NSL5253A	NSL5253A + NSC003

See Package Outline B Page 5

## NSL5274 T-1 Size Green LED Lamp

### General Description

The NSL5274 is a GaP solid state green LED encapsulated in an epoxy package. The lens configuration is designed for applications where space is a premium. High axial luminous intensity with a wide viewing angle characterize these small lamps.

### Features

- Wide viewing angle
- Wire wrap or solder leads
- IC compatible
- Reliable and rugged
- Low power consumption
- Long life
- Mount on 0.150 centers

### Applications

- Appliances
- Cameras
- Computers
- Indicator lamps
- Pilot lamps
- Circuit status
- Mobile and portable equipment
- High density arrays
- Vending machines
- Test equipment
- Medical instruments

### Absolute Maximum Ratings

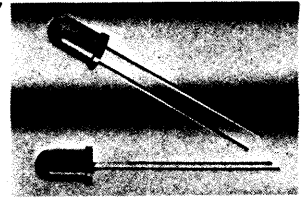
DC Forward Current	50 mA
Reverse Voltage	5.0V
Power Dissipation	100 mW
Derate Linearly 1.0 mW/°C above 25°C	
Peak Forward Current	1A
1 μs pulse, 300 pps	
Operating and Storage Temperature Range	-55°C to +100°C
85/85 Temp.—Humidity	1000 hrs
Lead Temperature (Soldering, 5 seconds)	230°C

### Electrical and Optical Characteristics (25°C)

Order Number NSL5274  
See Package Outline F Page 6

Parameter	Conditions	NSL5274	Units
Forward Voltage ( $V_F$ )	$I_F = 20 \text{ mA}$		
Typ		2.2	V
Max		3.0	V
Reverse Breakdown Voltage ( $BV_R$ )	$I_R = 100 \mu\text{A}$		
Min		5.0	V
Luminous Intensity (I)	$I_F = 20 \text{ mA}$		
Min		0.4	mcd
Typ		1.0	mcd
Peak Wavelength	$I_F = 20 \text{ mA}$		
Typ		565	nm
Spectral Width, Half-Intensity	$I_F = 20 \text{ mA}$		
Typ		40	nm
Light Rise and Fall Time, 10-90%	50Ω System		
Typ		50	ns
Angle of Half-Intensity Off Axis	$I_F = 20 \text{ mA}$		
Typ		45	degrees
Capacitance	$V = 0, 1 \text{ MHz}$		
Typ		75	pF





## NSL5350 Series Yellow LED Lamps

NSL5352A Yellow, Transparent-Lens LED Lamp

NSL5353A Yellow, Diffused-Lens LED Lamp

### General Description

These T1 3/4 size [0.200 inch (5 mm) dia] lamps are solid state LED's, encapsulated in an epoxy package. They are electrically similar but optically different owing to different lens configuration. These devices may be panel mounted with a plastic adaptor clip, directly soldered into a printed circuit board or the leads may be wire-wrapped.

### Applications

- Pilot lights
- Indicator lights
- GO-NO GO indicators
- Test equipment
- Computers
- Appliances

### Features

- High intensity
- Wide viewing angle
- Wire wrap or solder leads
- IC compatible
- Low power consumption

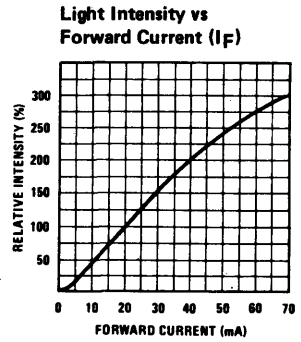
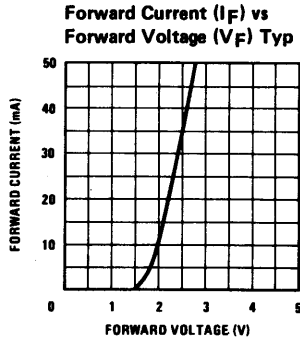
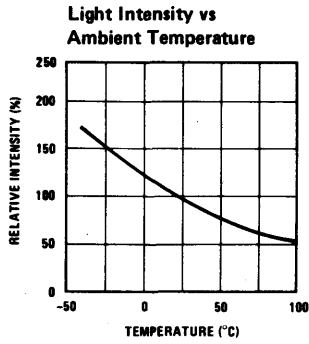
### Absolute Maximum Ratings

Forward Current, DC ( $I_F$ )	35 mA
Reverse Voltage	5.0V
Power Dissipation	105 mW
Derate linearly 1.14 mW/°C above 25°C	
Peak Forward Current	1A
1 $\mu$ s pulse, 300 pps	
Operating and Storage Temperature	
Range	-55°C to +100°C
Lead Temperature (Soldering)	260°C for 5 sec

### Electrical and Optical Characteristics (25°C)

PARAMETER	CONDITIONS	NSL5352A	NSL5353A	UNITS
Forward Voltage ( $V_F$ )	$I_F = 20$ mA	Typ	2.3	V
		Max	3.0	V
Reverse Breakdown Voltage ( $BV_R$ )	$I_R = 100$ $\mu$ A	Min	5.0	V
Luminous Intensity (I)	$I_F = 20$ mA	Min	10.0	mcd
		Typ	45.0	mcd
Peak Wavelength	$I_F = 20$ mA	Typ	585	nm
Spectral Width, Half-Intensity	$I_F = 20$ mA	Typ	40	nm
Light Rise and Fall Time 10-90%	Step Change of $I_F$ 50 $\Omega$ System	Typ	50	ns
Angle of Half-Intensity Off Axis	$I_F = 20$ mA	Typ	15	degrees
Capacitance	$V_F = 0,1$ MHz	Typ	75	pF

**Typical Performance Characteristics**



**Order Number:**

<b>LAMP</b>	<b>LAMP WITH</b>
	<b>MOUNTING CLIP</b>
<b>NSL5352A</b>	<b>NSL5352A + NSC003</b>
<b>NSL5353A</b>	<b>NSL5353A + NSC003</b>
<b>See Package Outline B Page 5</b>	

## NSL5374 T-1 Size Yellow LED Lamp

### General Description

The NSL5374 is a GaAsP/GaP solid state LED encapsulated in an epoxy package. The lens configuration is designed for applications where space is a premium. High axial luminous intensity with a wide viewing angle characterize these small lamps.

### Features

- Wide viewing angle
- Wire wrap or solder leads
- IC compatible
- Reliable and rugged
- Low power consumption
- Long life
- Mount on 0.150 centers

### Applications

- Appliances
- Cameras
- Computers
- Indicator lamps
- Pilot lamps
- Circuit status
- Mobile and portable equipment
- High density arrays
- Vending machines
- Test equipment
- Medical instruments

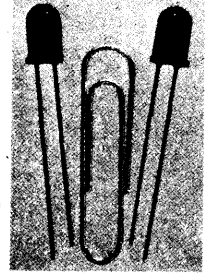
### Absolute Maximum Ratings

DC Forward Current	50 mA
Reverse Voltage	5.0V
Power Dissipation	100 mW
Derate Linearly 1.0 mW/°C above 25°C	
Peak Forward Current	1A
1 $\mu$ s pulse, 300 pps	
Operating and Storage Temperature Range	- 40°C to + 100°C
85/85 Temp.—Humidity	1000 hrs
Lead Temperature (Soldering, 5 seconds)	230°C

### Electrical and Optical Characteristics (25°C)

Order Number NSL5374  
See Package Outline F Page 6

Parameter	Conditions	NSL5374	Units
Forward Voltage ( $V_F$ )	$I_F = 20$ mA		
Typ		2.3	V
Max		3.0	V
Reverse Breakdown Voltage ( $BV_R$ )	$I_R = 100$ $\mu$ A		
Min		5.0	V
Luminous Intensity (I)	$I_F = 20$ mA		
Min		1.5	mcd
Typ		4.0	mcd
Peak Wavelength	$I_F = 20$ mA		
Typ		585	nm
Spectral Width, Half-Intensity	$I_F = 20$ mA		
Typ		40	nm
Light Rise and Fall Time, 10-90%	50 $\Omega$ System		
Typ		50	ns
Angle of Half-Intensity Off Axis	$I_F = 20$ mA		
Typ		45	degrees
Capacitance	V = 0, 1 MHz		
Typ		75	pF



## NSL5750 Series High Efficiency Red LED Lamps

NSL5752 Red Transparent-Lens LED Lamp

NSL5753 Red Diffused-Lens LED Lamp

### General Description

These T1 ¼ size (0.200" 5 mm dia) lamps are solid state LEDs, encapsulated in an epoxy package. They are electrically similar but optically different owing to different lens configuration. These devices may be panel mounted with a plastic adaptor clip, directly soldered into a printed circuit board or the leads may be wire wrapped.

### Features

- High intensity
- Wide viewing angle
- Wire wrap or solder leads
- IC compatible
- Low power consumption

### Applications

- Pilot lights
- Indicator lights
- GO-NO GO indicators
- Test equipment
- Computers
- Appliances

### Absolute Maximum Ratings

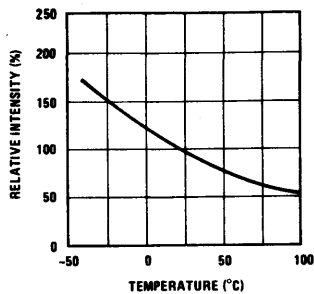
Forward Current, DC ( $I_F$ )	50 mA
Reverse Voltage	5.0V
Power Dissipation	100 mW
Derate Linearly 1.0 mW/°C above 25 °C	
Peak Forward Current	1A
1 $\mu$ s pulse, 300 pps	
Operating and Storage Temperature Range	- 40 °C to + 100 °C
Lead Temperature (Soldering, 5 seconds)	230 °C

### Electrical and Optical Characteristics (25 °C)

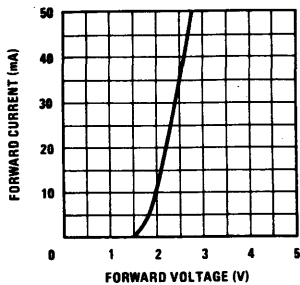
Parameter	Conditions	NSL5752	NSL5753	Units
Forward Voltage ( $V_F$ )	$I_F = 20$ mA			
Typ		2.1	2.1	V
Max		3.0	3.0	V
Reverse Breakdown Voltage ( $BV_R$ )	$I_R = 100$ $\mu$ A			
Min		5.0	5.0	V
Luminous Intensity (I)	$I_F = 20$ mA			
Min		17.0	3.0	mcd
Typ		40.0	6.0	mcd
Peak Wavelength	$I_F = 20$ mA			
Typ		635	635	nm
Spectral Width, Half-Intensity	$I_F = 20$ mA			
Typ		40	40	nm
Light Rise and Fall Time, 10-90%	Step Change of $I_F$			
Typ	50 $\Omega$ System	50	50	ns
Angle of Half-Intensity Off Axis	$I_F = 20$ mA			
Typ		15	30	degrees
Capacitance	$V_F = 0$ , 1 MHz			
Typ		75	75	pF

**Typical Performance Characteristics**

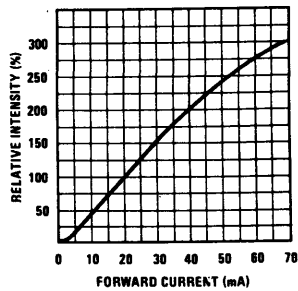
**Light Intensity vs Ambient Temperature**



**Forward Current ( $I_f$ ) vs Forward Voltage ( $V_f$ ) Typ**



**Light Intensity vs Forward Current ( $I_f$ )**



**Order Number:**

	<b>Lamp with Mounting Clip</b>
<b>Lamp</b>	
<b>NSL5752</b>	<b>NSL5752 + NSC003</b>
<b>NSL5753</b>	<b>NSL5753 + NSC003</b>
<b>See Package Outline B Page 5</b>	

## NSL5774 T-1 Size High Efficiency Red LED Lamp

### General Description

The NSL5774 is a GaAsP/GaP solid state high efficiency red LED encapsulated in an epoxy package. The lens configuration is designed for applications where space is a premium. High axial luminous intensity with a wide viewing angle characterize these small lamps.

### Features

- Wide viewing angle
- Wire wrap or solder leads
- IC compatible
- Reliable and rugged
- Low power consumption
- Long life
- Mount on 0.150 centers

### Applications

- Appliances
- Cameras
- Computers
- Indicator lamps
- Pilot lamps
- Circuit status
- Mobile and portable equipment
- High density arrays
- Vending machines
- Test equipment
- Medical instruments

### Absolute Maximum Ratings

DC Forward Current	50 mA
Reverse Voltage	5.0V
Power Dissipation	100 mW
Derate Linearly 1.0 mW/°C above 25 °C	
Peak Forward Current	1A
1 $\mu$ s pulse, 300 pps	
Operating and Storage Temperature Range	- 40 °C to + 100 °C
85/85 Temp.—Humidity	1000 hrs
Lead Temperature (Soldering, 5 seconds)	230 °C

### Electrical and Optical Characteristics (25 °C)

Order Number NSL5774  
See Package Outline F Page 6

Parameter	Conditions	NSL5774	Units
Forward Voltage ( $V_F$ )	$I_F = 20$ mA		
Typ		2.1	V
Max		3.0	V
Reverse Breakdown Voltage ( $BV_R$ )	$I_R = 100$ $\mu$ A		
Min		5.0	V
Luminous Intensity (I)	$I_F = 20$ mA		
Min		1.5	mcd
Typ		5.0	mcd
Peak Wavelength	$I_F = 20$ mA		
Typ		635	nm
Spectral Width, Half-Intensity	$I_F = 20$ mA		
Typ		40	nm
Light Rise and Fall Time, 10-90%	50 $\Omega$ System		
Typ		50	ns
Angle of Half-Intensity Off Axis	$I_F = 20$ mA		
Typ		45	degrees
Capacitance	V = 0, 1 MHz		
Typ		75	pF

## NSL5X124 Series LED Lamps

NSL52124 0.220" Green Rectangular Legend Lamp  
 NSL53124 0.220" Yellow Rectangular Legend Lamp  
 NSL57124 0.220" High Efficiency Red Rectangular Legend Lamp

### Product Description

This series of rectangularly shaped solid state indicators is available in green, yellow, and red. The rectangular lighted area is uniformly lit by a high performance LED chip.

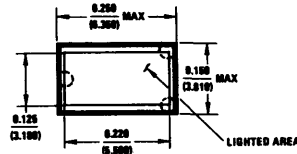
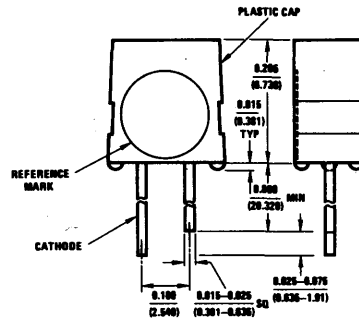
### Features

- 0.220" × 0.125" lighted area
- Stackable in X or Y direction
- High brightness—typically 3 mcd @ 20 mA
- Solid state reliability
- Compact, rugged, lightweight
- No light leakage from unit sides
- Mounting grommet available (see MP65)

### Applications

- Legend backlighting
- Illuminated pushbutton
- Panel indicator
- Bargraph meter

### Physical Dimensions inches (millimeters)



Note: Tolerance  $\pm 0.010$  ( $\pm 0.254$ ) unless specified

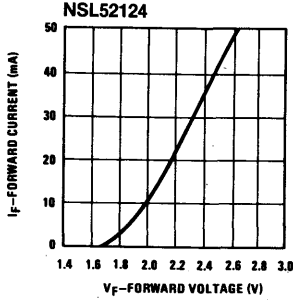
### Electrical and Optical Characteristics (25°C Free Air Temperature)

Parameter	Conditions	NSL52124	NSL53124	NSL57124	Units	
Forward Voltage ( $V_F$ )	Typ	$I_F = 20 \text{ mA}$	2.0	2.0	2.0	V
	Max					3.0
Luminous Intensity	Min	$I_F = 20 \text{ mA}$	1.0	1.0	1.0	mcd
	Typ					3.0
Peak Wavelength	$I_F = 20 \text{ mA}$	565	585	635	nm	
Spectral Line Half Width	$I_F = 20 \text{ mA}$	45	45	45	nm	
Reverse Voltage ( $V_R$ )	Min	$I_R = 100 \mu\text{A}$	5	5	5	V
	Typ					25
Reverse Current ( $I_R$ )	Typ	$V_R = 5.0 \text{ V}$	20	20	20	nA
	Max					100
Capacitance	$V = 0$	45	45	45	pF	

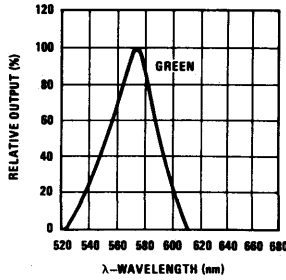
## Absolute Maximum Ratings

Power Dissipation at 25°C	105 mW	Forward Current at 25°C	35 mA
Derate Linearly from 25°C	1.14 mW/°C	Reverse Voltage	5.0V
Storage and Operating Temperature	-55°C to 100°C	Lead Temperature (Soldering, 5 seconds)	260°C
Peak Forward Current (1 μs pulse width, 300 pps)	1A		

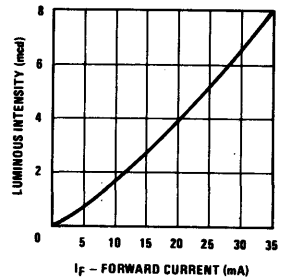
## Typical Performance Characteristics (Continued)



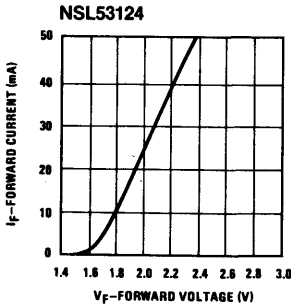
**FIGURE 1. Forward Current vs Forward Voltage**



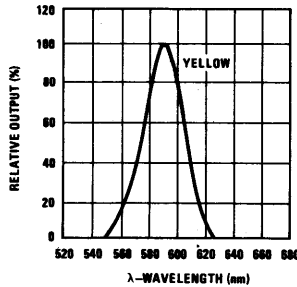
**FIGURE 2. Spectral Response**



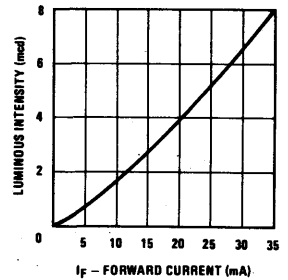
**FIGURE 3. Luminous Intensity vs Forward Current**



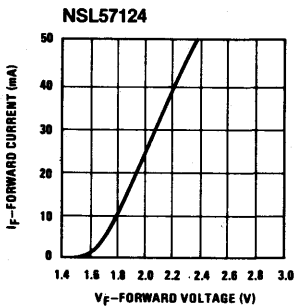
**FIGURE 4. Forward Current vs Forward Voltage**



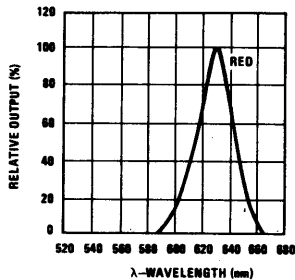
**FIGURE 5. Spectral Response**



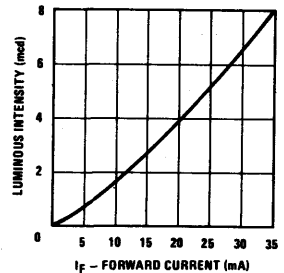
**FIGURE 6. Luminous Intensity vs Forward Current**



**FIGURE 7. Forward Current vs Forward Voltage**

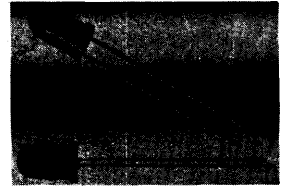


**FIGURE 8. Spectral Response**



**FIGURE 9. Luminous Intensity vs Forward Current**





## NSL605X Series Red LED Lamps

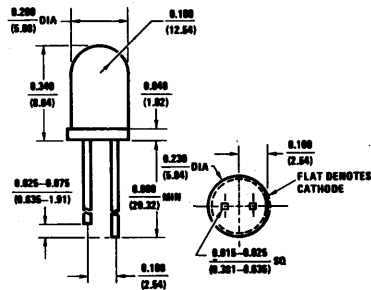
- NSL6050 Water-Clear Lens
- NSL6051 Milk-White Diffused Lens
- NSL6052 Red Transparent Lens
- NSL6053 Light Red Diffused Lens
- NSL6055 Red Diffused Lens, Wide Viewing Angle
- NSL6056 Dark Red Diffused Lens

### Product Description

Solid state lamps of the NSL605X series are composed of standard red Gallium Arsenide Phosphide light emitting diodes encapsulated in epoxy packages of different color shades and levels of diffusion to produce various lens effects. These lamps are exact second-source replacement of the General Instrument/Monsanto MV5050 series solid state indicators.

- Optical coupling
- Pilot lights
- Status indicators

### Physical Dimensions inches (millimeters)



Tolerances  $\pm 0.015$  ( $\pm 0.381$ )

### Features

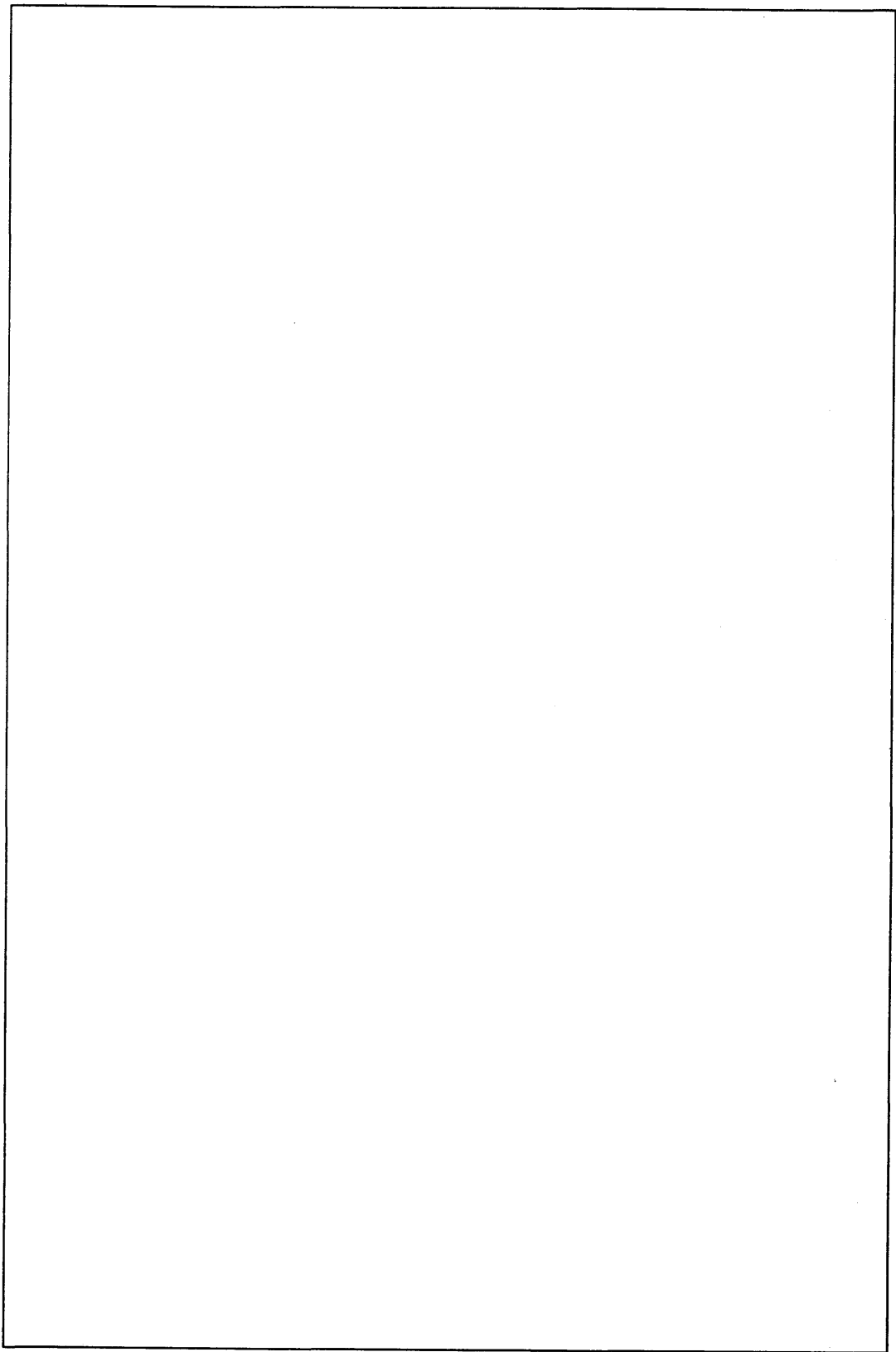
- High intensity red light source
- Low power requirements
- Long life—solid state reliability
- IC compatible
- Versatile mounting
- Mounting hardware available on request

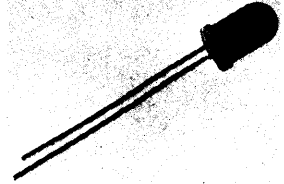
### Applications

- Indicator lamps for front panels
- Illuminators for back-lighting

## Electrical and Optical Characteristics

**Typical Performance  
Characteristics  
see page 35-9  
MV505X Series**





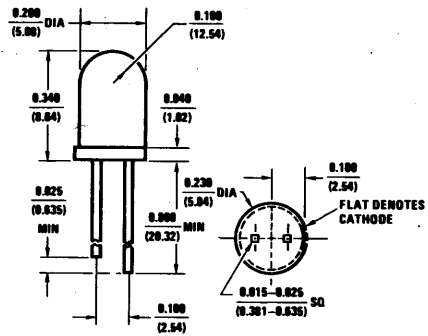
## NSL6X52 Series LED Lamps

NSL6152 Orange Emitter, Transparent Orange Lens  
 NSL6252 Green Emitter, Transparent Green Lens  
 NSL6352 Yellow Emitter, Transparent Yellow Lens  
 NSL6752 Orange-Red Emitter, Transparent Red Lens

### Product Description

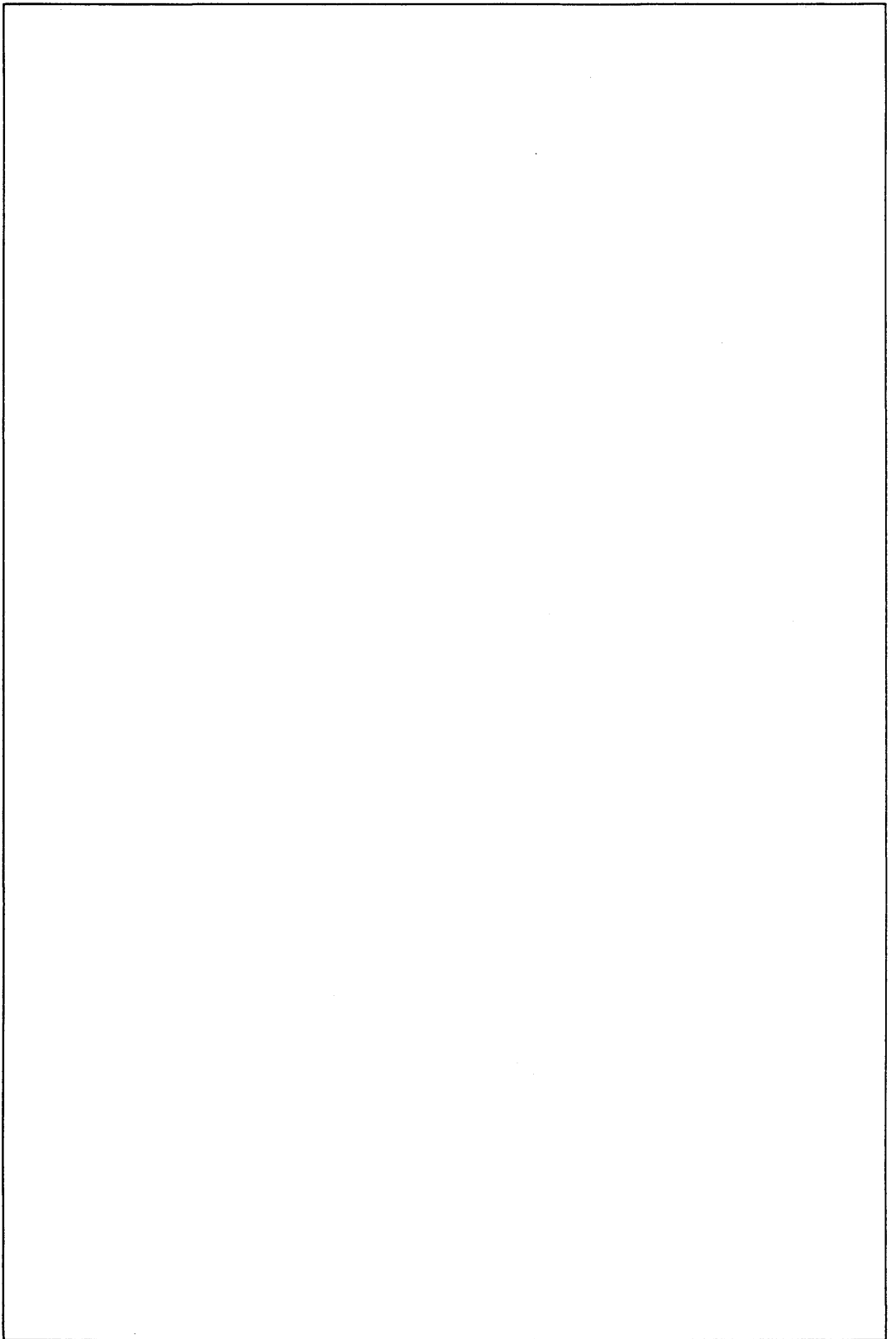
The NSL6X52 LED lamp series are LED emitters packaged in a plastic non-diffused lens of the same color as light from emitter.

### Physical Dimensions Inches (millimeters)



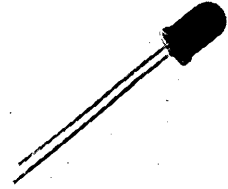
Tolerances  $\pm 0.010$  ( $\pm 0.254$ )

**Typical Performance  
 Characteristics  
 see page 35-11  
 MV5X52 Series**



## NSL6X53, NSL6X54 Series LED Lamps

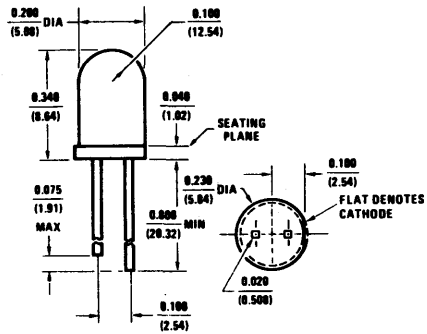
- NSL6153 Orange Emitter — Diffused Orange Lens
- NSL6154 Orange Emitter — Lightly Diffused Orange Lens
- NSL6253 Green Emitter — Diffused Green Lens
- NSL6254 Green Emitter — Lightly Diffused Green Lens
- NSL6353 Yellow Emitter — Diffused Yellow Lens
- NSL6354 Yellow Emitter — Lightly Diffused Yellow Lens
- NSL6753 Orange-Red Emitter — Diffused Red Lens
- NSL6754 Orange-Red Emitter — Lightly Diffused Red Lens



### Product Description

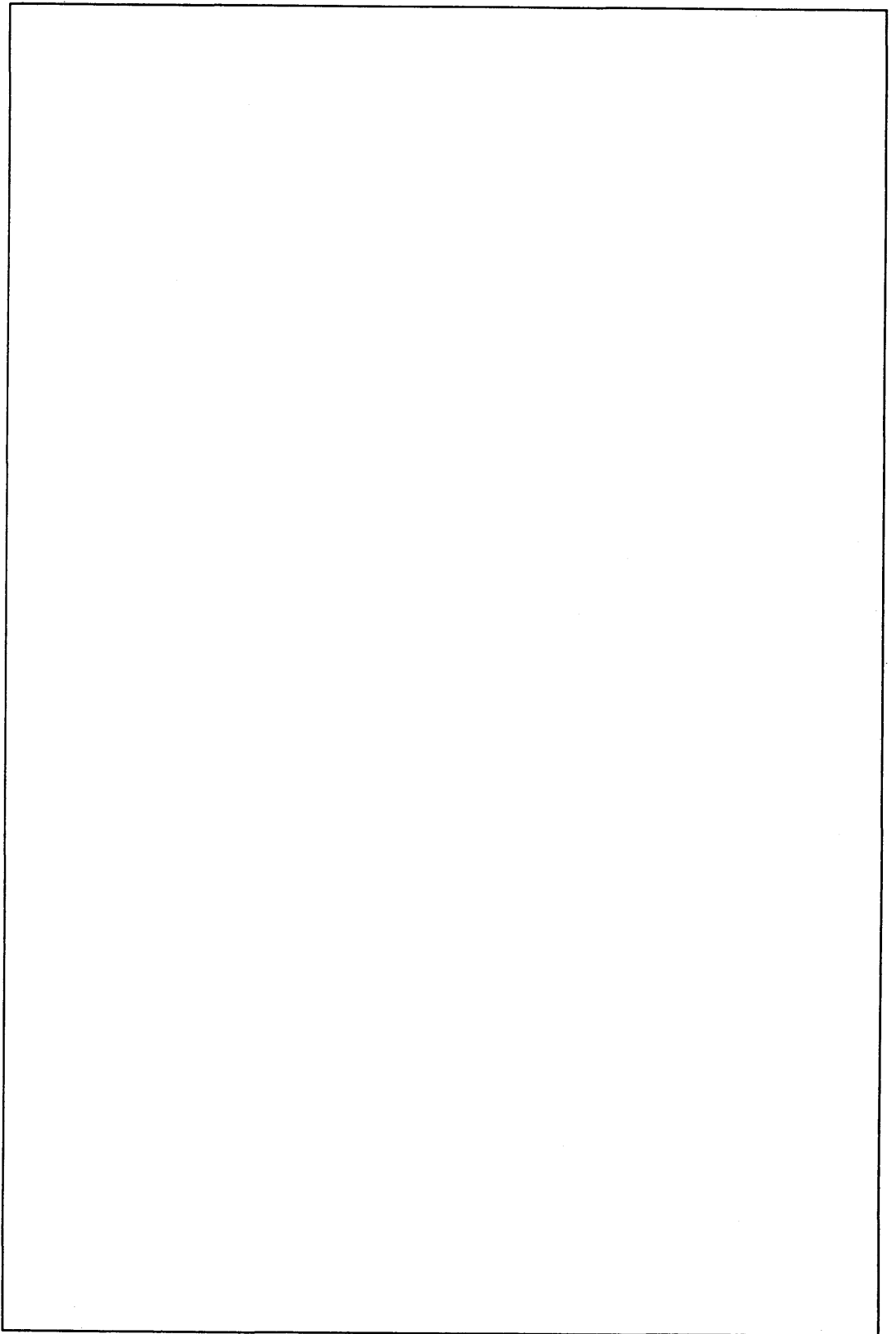
The NSL6X53 and NSL6X54 series of LED lamps are LED emitters packaged in colored, diffused lenses. The NSL6X53 lens diffusion level produces a soft, wide angle emission pattern. The lighter diffusion level of the NSL6X54 lens produces a flood-light (narrow beam) effect.

### Physical Dimensions inches (millimeters)



Tolerances  $\pm 0.010 (\pm 0.254)$

**Typical Performance  
Characteristics  
see page 35-13  
MV5X53, MV5X54**





## MV505X Series Red LED Lamps

- MV5050 Water-Clear Lens
- MV5051 Milk-White Diffused Lens
- MV5052 Red Transparent Lens
- MV5053 Light Red Diffused Lens
- MV5055 Red Diffused Lens, Wide Viewing Angle
- MV5056 Dark Red Diffused Lens

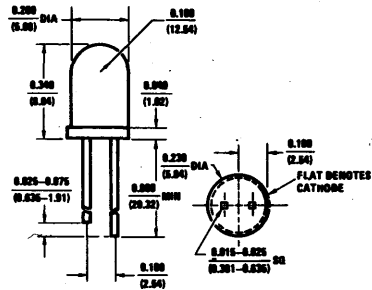


### Product Description

Solid state lamps of the MV505X series are composed of standard red Gallium Arsenide Phosphide light emitting diodes encapsulated in epoxy packages of different color shades and levels of diffusion to produce various lens effects. These lamps are exact second-source replacements of the General Instrument/Monsanto MV5050 series solid state indicators.

- Optical coupling
- Pilot lights
- Status indicators

### Physical Dimensions Inches (millimeters)



Tolerances  $\pm 0.015 (\pm 0.381)$

### Features

- High intensity red light source
- Low power requirements
- Long life—solid state reliability
- IC compatible
- Versatile mounting
- Mounting hardware available on request

### Applications

- Indicator lamps for front panels
- Illuminators for back-lighting

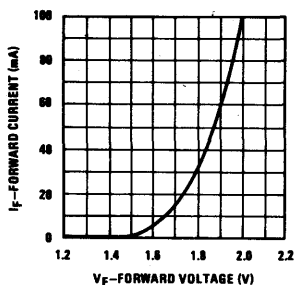
### Electrical and Optical Characteristics (25°C Free Air Temperature)

Parameter	Conditions	MV5050	MV5051	MV5052	MV5053	MV5055	MV5056	Units
Forward Voltage ( $V_F$ )	Typ	$I_F = 20 \text{ mA}$	1.7	1.7	1.7	1.7	1.7	V
	Max	$I_F = 20 \text{ mA}$	2.2	2.2	2.2	2.2	2.2	V
Luminous Intensity ( $V_L$ )	Typ	$I_F = 20 \text{ mA}$	2.0	1.6	2.0	1.6	0.6	mcd
	Min	$I_F = 20 \text{ mA}$	0.5	0.4	0.7	0.5	0.1	mcd
Peak Wave Length	$I_F = 20 \text{ mA}$	670	670	670	670	670	670	nm
Spectral Line Half Width	$I_F = 20 \text{ mA}$	20	20	20	20	20	20	nm
Capacitance	Typ	$V = 0$	30	30	30	30	30	pF
	Reverse Voltage ( $V_R$ )							
Min	$I_R = 100 \mu\text{A}$	5	5	5	5	5	5	V
Typ	$I_R = 100 \mu\text{A}$	25	25	25	25	25	25	V
Reverse Current ( $I_R$ )	Max	$V_R = 5.0\text{V}$	100	100	100	100	100	$\mu\text{A}$
	Typ	$V_R = 5.0\text{V}$	20	15	5	5	5	nA
Rise Time	10%–90% 50 $\Omega$ System	50	50	50	50	50	50	ns
Fall Time	90%–10% 50 $\Omega$ System	50	50	50	50	50	50	ns
Viewing Angle	Figures 5 and 6	50	72	72	80	150	110	Degrees

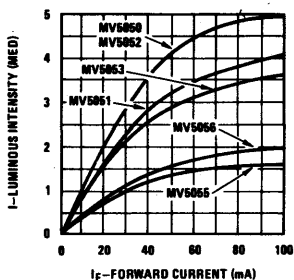
## Absolute Maximum Ratings

Power Dissipation @ 25°C Ambient	180 mW
Derate Linearly from 25°C	2.0 mW/°C
Storage and Operating Temperatures	-55°C to 100°C
Continuous Forward Current @ 25°C	100 mA
Continuous Forward Current @ 100°C	15 mA
Peak Forward Current (1 μs Pulse, 0.3% Duty Cycle)	1.0A
Reverse Voltage	5.0V
Lead Temperature (Soldering, 5 seconds)	260°C

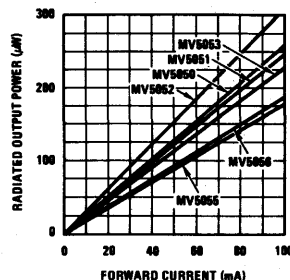
## Typical Performance Characteristics (25°C Free Air Temperature Unless Otherwise Specified)



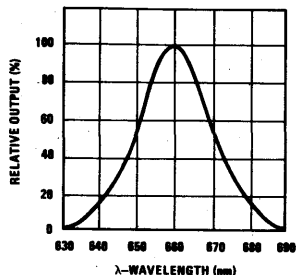
**FIGURE 1. Forward Current vs Forward Voltage**



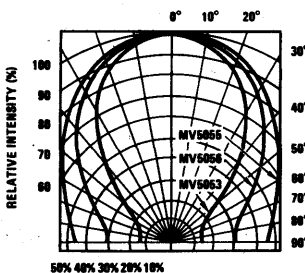
**FIGURE 2. Luminous Intensity vs Forward Current**



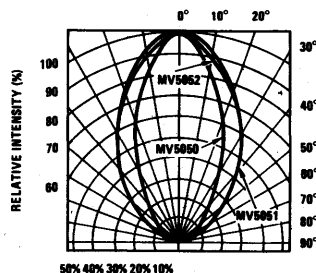
**FIGURE 3. ROP vs Forward Current**



**FIGURE 4. Spectral Response**



**FIGURE 5. Spatial Distribution**

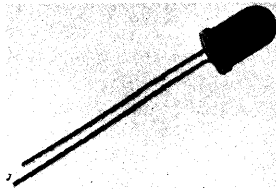


**FIGURE 6. Spatial Distribution**

## Order Information

Customer-ID	will ship
MV5050	NSL6050 + NSC003
MV5051	NSL6051 + NSC003
MV5052	NSL6052 + NSC003
MV5053	NSL6053 + NSC003
MV5055	NSL6055 + NSC003
MV5056	NSL6056 + NSC003





## MV5X52 Series LED Lamps

**MV5152 Orange Emitter, Transparent Orange Lens**  
**MV5252 Green Emitter, Transparent Green Lens**  
**MV5352 Yellow Emitter, Transparent Yellow Lens**  
**MV5752 Orange-Red Emitter, Transparent Red Lens**

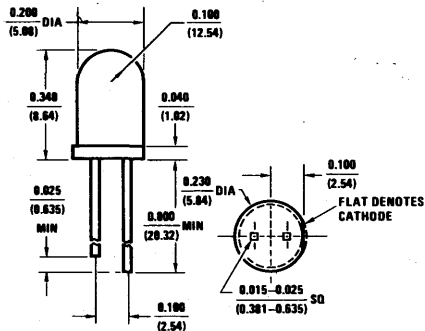
### Product Description

The MV5X52 LED lamp series are LED emitters packaged in a plastic non-diffused lens of the same color as light from emitter.

### Physical Dimensions inches (millimeters)

### Order Information

<b>Customer-ID</b>	<b>will ship</b>
MV5152	NSL6152 + NSC003
MV5252	NSL6252 + NSC003
MV5352	NSL6352 + NSC003
MV5752	NSL6752 + NSC003



Tolerances  $\pm 0.010$  ( $\pm 0.254$ )

### Electrical and Optical Characteristics

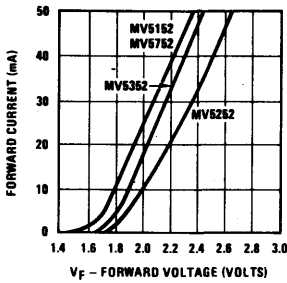
Parameter	Conditions	MV5152	MV5252	MV5352	MV5752	Units	
Forward Voltage ( $V_F$ )	Typ	$I_F = 20$ mA	2.0	2.2	2.1	2.0	V
	Max	$I_F = 20$ mA	3.0	3.0	3.0	3.0	V
Luminous Intensity ( $V_L$ )	Min	$I_F = 20$ mA	17.0	2.0	10.0	17.0	mcd
	Typ	$I_F = 20$ mA	40.0	15.0	45.0	40.0	mcd
Peak Wavelength	$I_F = 20$ mA	635	565	585	635	nm	
Spectral Line Half Width	$I_F = 20$ mA	45	35	35	45	nm	
Capacitance							
Typ	$V = 0$	45	45	45	45	pF	
Reverse Voltage ( $V_R$ )	Min	$I_R = 100$ $\mu$ A	5	5	5	5	V
	Typ	$I_R = 100$ $\mu$ A	25	25	25	25	V
Reverse Current ( $I_R$ )	Max	$V_R = 5.0$ V	100	100	100	100	$\mu$ A
	Typ	$V_R = 5.0$ V	20	20	20	20	nA
Viewing Angle (Total)		28	28	28	28	Degrees	

## Absolute Maximum Ratings

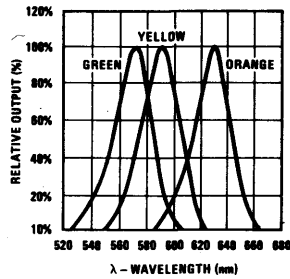
Power Dissipation at 25 °C Ambient	105 mW
Derate Linearly from 25 °C	1.14 mW/°C
Storage and Operating Temperatures	- 55 °C to 100 °C
Continuous Forward Current at 25 °C	35 mA
Continuous Forward Current at 100 °C	10 mA
Peak Forward Current (1 μs Pulse, 0.3% Duty Cycle)	1.0A
Reverse Voltage	5.0V
Lead Temperature (Soldering, 5 seconds)	230 °C

## Typical Performance Characteristics

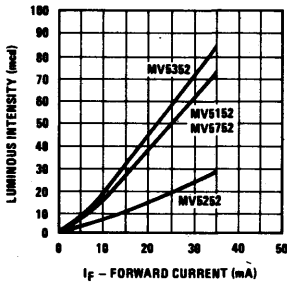
(25 °C Free Air Temperature Unless Otherwise Specified)



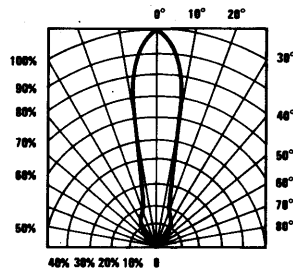
**FIGURE 1. Forward Current vs Forward Voltage**



**FIGURE 2. Spectral Response**



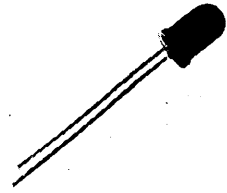
**FIGURE 3. Brightness vs Forward Current**



**FIGURE 4. Spatial Distribution (MV5352, MV5252, MV5152, MV5752)**

## MV5X53, MV5X54 Series LED Lamps

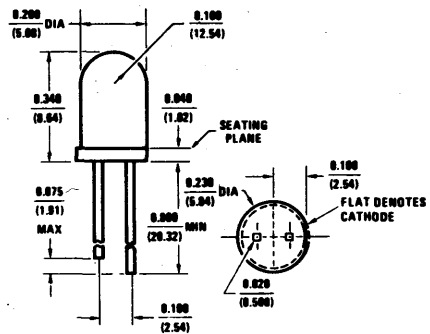
- MV5153 Orange Emitter — Diffused Orange Lens
- MV5154 Orange Emitter — Lightly Diffused Orange Lens
- MV5253 Green Emitter — Diffused Green Lens
- MV5254 Green Emitter — Lightly Diffused Green Lens
- MV5353 Yellow Emitter — Diffused Yellow Lens
- MV5354 Yellow Emitter — Lightly Diffused Yellow Lens
- MV5753 Orange-Red Emitter — Diffused Red Lens
- MV5754 Orange-Red Emitter — Lightly Diffused Red Lens



### Product Description

The MV5X53 and MV5X54 series of LED lamps are LED emitters packaged in colored, diffused lenses. The MV5X53 lens diffusion level produces a soft, wide angle emission pattern. The lighter diffusion level of the MV5X54 lens produces a flood-light (narrow beam) effect.

### Physical Dimensions (Inches (millimeters))



Tolerances  $\pm 0.010 (\pm 0.254)$

### Order Information

Customer-ID	will ship
MV5153	NSL6153 + NSC003
MV5154	NSL6154 + NSC003
MV5253	NSL6253 + NSC003
MV5254	NSL6254 + NSC003
MV5353	NSL6353 + NSC003
MV5354	NSL6354 + NSC003
MV5753	NSL6753 + NSC003
MV5754	NSL6754 + NSC003

### Electrical and Optical Characteristics (25°C Free Air Temperature)

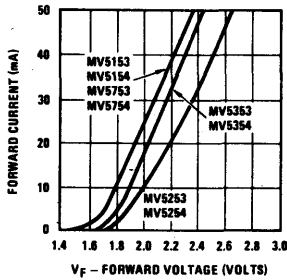
Parameter	Conditions	MV5153	MV5154	MV5253	MV5254	MV5353	MV5354	MV5753	MV5754	Units
Forward Voltage (V <sub>F</sub> )	Typ	I <sub>F</sub> = 20 mA	2.0	2.0	2.2	2.2	2.1	2.1	2.0	V
	Max	I <sub>F</sub> = 20 mA	3.0	3.0	3.0	3.0	3.0	3.0	3.0	V
Luminous Intensity (V <sub>L</sub> )	Min	I <sub>F</sub> = 20 mA	3.0	3.0	0.8	0.9	2.5	3.0	3.0	mcd
	Typ	I <sub>F</sub> = 20 mA	6.0	8.0	1.5	3.0	6.0	10.0	6.0	mcd
Peak Wavelength	I <sub>F</sub> = 20 mA	635	635	565	565	585	585	635	635	nm
Spectral Line Half Width	I <sub>F</sub> = 20 mA	45	45	35	35	35	35	45	45	nm
Reverse Voltage (V <sub>R</sub> )	Min	I <sub>R</sub> = 100 μA	5	5	5	5	5	5	5	V
	Typ	I <sub>R</sub> = 100 μA	25	25	25	25	25	25	25	V
Reverse Current (I <sub>R</sub> )	Max	V <sub>R</sub> = 5.0V	100	100	100	100	100	100	100	μA
	Typ	V <sub>R</sub> = 5.0V	20	20	20	20	20	20	20	nA
Viewing Angle (Total)			65	24	65	24	65	24	65	Degrees

## Absolute Maximum Ratings

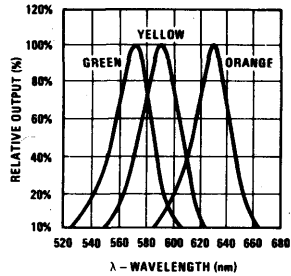
Power Dissipation at 25°C Ambient	105 mW
Derate Linearly from 25°C	1.14 mW/°C
Storage and Operating Temperatures	- 55°C to 100°C
Continuous Forward Current at 25°C	35 mA
Continuous Forward Current at 100°C	10 mA
Peak Forward Current (1 μs Pulse, 0.3% Duty Cycle)	1.0A
Reverse Voltage	5.0V
Lead Temperature (Soldering, 5 seconds)	230°C

## Typical Performance Characteristics

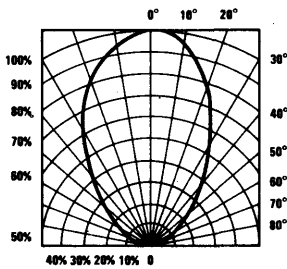
(25°C Free Air Temperature Unless Otherwise Specified)



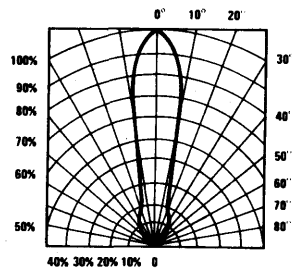
**FIGURE 1. Forward Current vs Forward Voltage**



**FIGURE 2. Spectral Response**

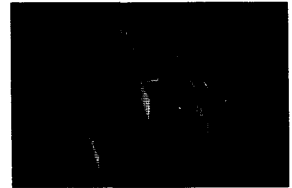


**FIGURE 3. Spatial Distribution (MV5753, MV5353, MV5253, MV5153)**



**FIGURE 4. Spatial Distribution (MV5754, MV5354, MV5254, MV5154)**

## MV5X124 Series LED Lamps

**MV52124 0.220" Green Rectangular Legend Lamp**
**MV53124 0.220" Yellow Rectangular Legend Lamp**
**MV57124 0.220" High Efficiency Red Rectangular Legend Lamp**


### Product Description

This series of rectangularly shaped solid state indicators is available in green, yellow, and red. The rectangular lighted area is uniformly lit by a high performance LED chip.

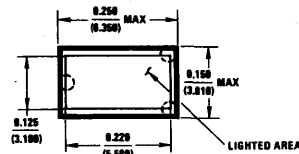
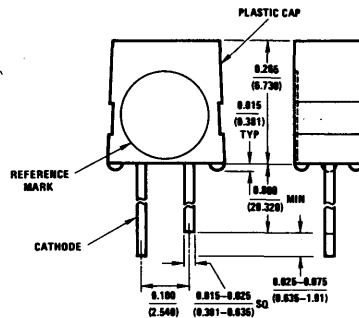
### Features

- 0.220" x 0.125" lighted area
- Stackable in X or Y direction
- High brightness—typically 3 mcd @ 20 mA
- Solid state reliability
- Compact, rugged, lightweight
- No light leakage from unit sides
- Mounting grommet available (see MP65)

### Applications

- Legend backlighting
- Illuminated pushbutton
- Panel indicator
- Bargraph meter

### Physical Dimensions inches (millimeters)



Note: Tolerance  $\pm 0.010$  ( $\pm 0.254$ ) unless specified

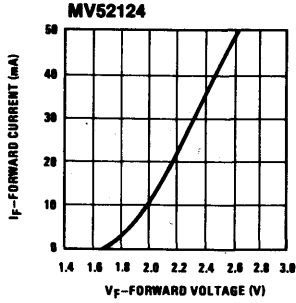
### Electrical and Optical Characteristics (25°C Free Air Temperature)

Parameter	Conditions	MV52124	MV53124	MV57124	Units
Forward Voltage ( $V_F$ )	Typ	2.0	2.0	2.0	V
	Max	3.0	3.0	3.0	V
Luminous Intensity	Min	1.0	1.0	1.0	mcd
	Typ	3.0	4.0	4.0	mcd
Peak Wavelength	$I_F = 20$ mA	565	585	635	nm
Spectral Line Half Width	$I_F = 20$ mA	45	45	45	nm
Reverse Voltage ( $V_R$ )	Min	5	5	5	V
	Typ	25	25	25	V
Reverse Current ( $I_R$ )	Typ	20	20	20	nA
	Max	100	100	100	$\mu$ A
Capacitance	$V = 0$	45	45	45	pF

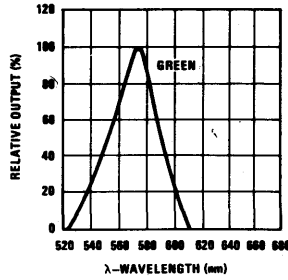
## Absolute Maximum Ratings

Power Dissipation at 25°C	105 mW	Forward Current at 25°C	35 mA
Derate Linearly from 25°C	1.14 mW/°C	Reverse Voltage	5.0V
Storage and Operating Temperature	-55°C to 100°C	Lead Temperature (Soldering, 5 seconds)	260°C
Peak Forward Current (1 μs pulse width, 300 pps)	1A		

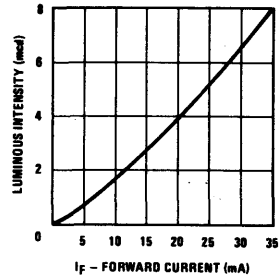
## Typical Performance Characteristics (Continued)



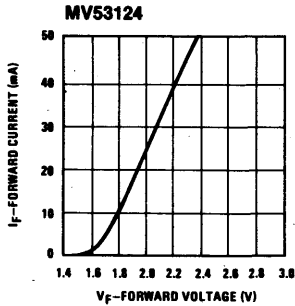
**FIGURE 1. Forward Current vs Forward Voltage**



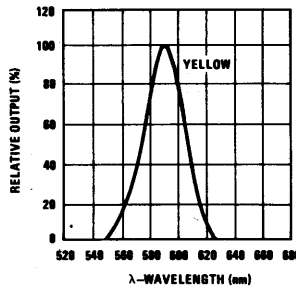
**FIGURE 2. Spectral Response**



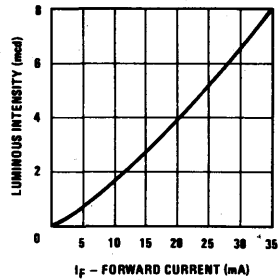
**FIGURE 3. Luminous Intensity vs Forward Current**



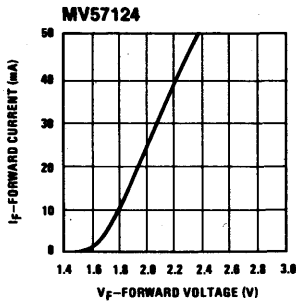
**FIGURE 4. Forward Current vs Forward Voltage**



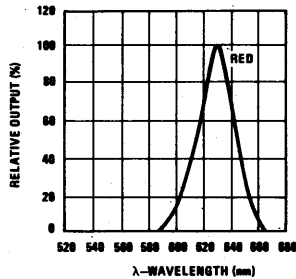
**FIGURE 5. Spectral Response**



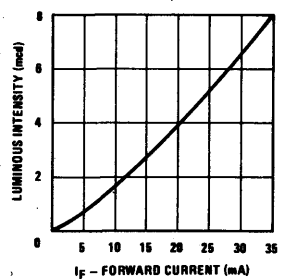
**FIGURE 6. Luminous Intensity vs Forward Current**



**FIGURE 7. Forward Current vs Forward Voltage**



**FIGURE 8. Spectral Response**



**FIGURE 9. Luminous Intensity vs Forward Current**

# Constant Current LED

National Semiconductor  
 Application Note 153  
 Peter Lefferts  
 October 1975



AN-153 Constant Current LED

## INTRODUCTION

The NSL4944 is a simple two-lead device normally used as an AC or DC indicator, yet can also be used as a rectifier and constant current source at the same time in associated circuitry. A number of such applications will be illustrated. Further, most of the regulating circuitry is not in series with the LED. This allows the complete regulated LED to operate at only about 300 mV more than a standard red LED. Thus the NSL4944 operates on half the voltage needed by previously available regulated or resistor LEDs. The device is rated for a maximum of 18 V forward and reverse.

These characteristics provide several advantages. Unloaded TTL gates provide enough voltage, in either high or low states, to directly drive the universal indicator. Size and weight can be saved in instruments with a number of indicator lights by reducing the size of filter capacitors or voltage regulators. The NSL4944 can operate on unfiltered DC or at somewhat reduced intensity on 3 to 12 VAC rms. Since the IC within the regulated LED blocks reverse voltage, the device can be used as a low voltage rectifier or polarity indicator.

## DESIGN FEATURES

The LED and its current source, as illustrated in Figure 1, both fit within a standard LED package. The typical operating voltages shown allow the device to operate with lower supplies and take up less room than an LED and component dropping resistor.

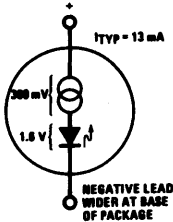


FIGURE 1. Equivalent Circuit

Figure 2 shows how some of the operating features of the NSL4944 are achieved. The rectifying characteristic occurs because the only input to the device passes through the IC's PNP emitters. These have a high reverse voltage in standard linear processing. The voltage reference and comparison amplifier operate from the same low voltage that the LED does. The big PNP transistor which passes both  $I_{LED}$  and  $I_{REF}$  can be operated almost in saturation since the comparison amplifier can pull the PNP base down to only one volt from common.

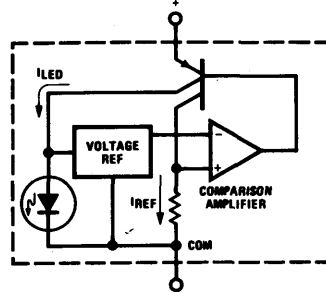


FIGURE 2. Simplified Schematic

## INDICATOR POWERING

The following figures contain some of the innumerable ways of providing power to the NSL4944.

Power and parts count is minimized by powering the indicator from a low voltage transformer winding as shown in Figure 3. This method, however, provides only

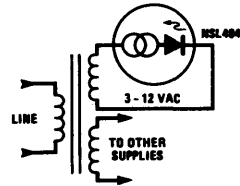


FIGURE 3. AC Power

half intensity light, but the apparent visual decrease is not as great. Some flicker occurs if the observer moves his head rapidly. The supply of Figure 4 will provide up to 87% of maximum light output. The bulk of a filter capacitor is still not needed, and at 12 VAC in, flicker will be almost imperceptible since the LED "off" periods will be less than a millisecond. In both situations, the indicator may be switched a number of ways, including bipolar transistors, since only DC can pass through the indicator.

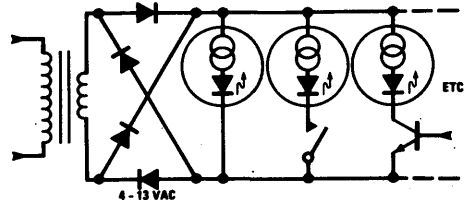


FIGURE 4. Unfiltered DC Power

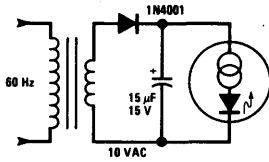


FIGURE 5. Minimizing DC Filtering

As shown in Figure 5, full intensity and zero possible flicker are achieved by minimal DC filtering. The small capacitor shown operates with 10 V p-p ripple and only about 8 V average DC, while the constant current drain characteristics of the NSL4944 allow only a few percent change in light intensity. If a system or instrument with a regulated supply has a number of LED indicators, regulator size and dissipation can be minimized by powering the regulated LEDs from the unregulated voltage.

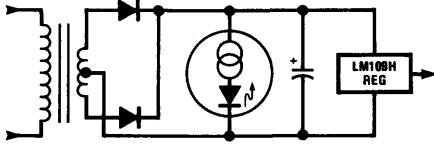


FIGURE 6. Unregulated DC

LOGIC APPLICATIONS

The low operating voltage and constant current characteristics make the regulated LED an ideal status indicator for digital circuitry. An interesting fact to keep in mind is that full regulator current is not needed to light the LED. If, for example, only 8 mA is available (from a voltage of 1.6 to 1.9 V) the LED will light at a somewhat reduced intensity. The regulator will be switched full on instead of current limiting . . . but in such a situation it doesn't matter.

Any circuit capable of supplying 10 to 20 mA and a voltage swing of at least 1 V can switch the NSL4944 from an off to an on state. Within 25°C of room temperature, an input voltage of 1.3 V will produce little or no light, and 2.3 V will produce 70% to 90% of full output. However, with a small signal change, the pre-existing biases must be correct. The output swing of a

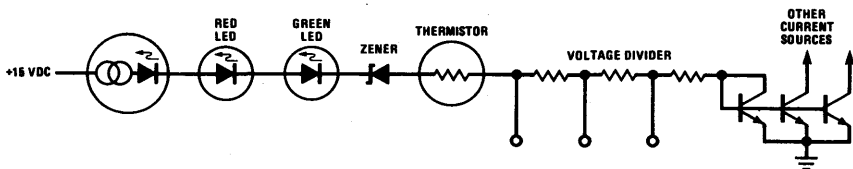


FIGURE 9. Uses for Constant Current

TTL stage goes much closer to ground than to the 5 V supply. Therefore, Figure 7-C requires a 3.5 V supply for the indicators to have complete on-off switching.

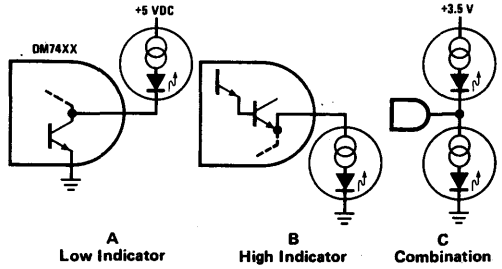


FIGURE 7. TTL Indicators

CIRCUIT APPLICATIONS

In many circuits or small instruments the need for a constant current source or current limiter arises. FETs can generally only be used as low current sources, so for 10 mA or more, construction of a current source requires 3, 4, or more parts. If an indicator or pilot light is also needed, the regulated LED may be a very economical source of the needed constant current.

The examples below illustrate all three characteristics of the NSL4944. It is a combined rectifier, constant current source, and pilot light.

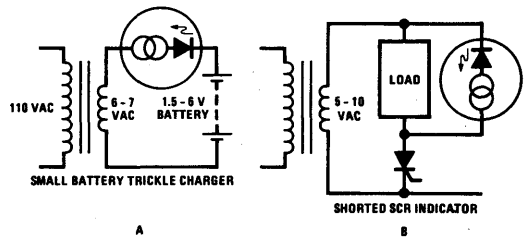


FIGURE 8.

Constant currents have a number of circuit or equipment design uses. Some of these have been combined for illustration in Figure 9. A number of LEDs can "share" a single constant current LED. Further, any of the ordinary LEDs can be turned on and off by a shunting switch without affecting operation of any of the others.



In equipment with unregulated supplies, or supplies having some unfiltered ripple, the 20,000  $\Omega$  impedance of the NSL4944 current source will be helpful. Supply ripple and variation passed on to Zener diodes, thermistors, and low value voltage divider bias sources will be greatly reduced. The sensitivity of low value thermistors to temperature changes will be increased. If practical, the regulated LED should be put in the same, or similar temperature environment as the thermistor used for temperature measurement. Otherwise a 20 to 40 degree temperature change at the LED would lead to an apparent one degree change sensed at the thermistor. Multiple current sources find use in some audio amplifier designs, and in power op-amp modules.

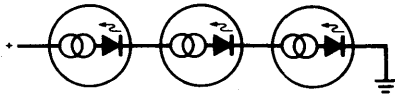


FIGURE 10. Series NSL4944s

There are some characteristics of series regulated LEDs, and current sources in general, that should be kept in mind. All the LEDs will light properly, and the string will run at the current of the least current source. This lowest value source will absorb most of the supply voltage, with the other LEDs having only the starting voltage of about 2 V across them. Thus the maximum forward voltage increases only slightly as more devices are added. In the example above it would be 22 V. However, due to non-linear reverse current characteristics, maximum reverse voltages can be added.

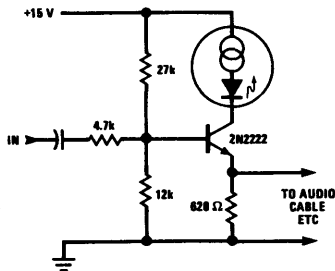


FIGURE 11. Current Limiting and Short Protection

A current source can also be a current limiter. Figure 11 shows an NSL4944 put in the collector of an emitter follower such as might be used in a pre-amp or mike mixer cable driver.

Normally voltage across the LED is only 2 V, allowing almost full supply-to-supply swing of the emitter follower output. In comparison a limiting resistor would either greatly increase output impedance, or severely limit output swing. However, if the output cable is accidentally shorted, only a little more than the rated current of the LED will flow. Output transistor dissipation actually decreases under emitter short conditions.

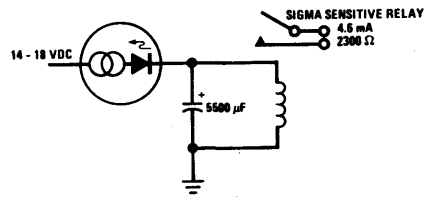


FIGURE 12. Six Second Time Delay

Logically, a constant current source is helpful in designing time delay circuits. If the circuit of Figure 12 were built with a resistor, the timing period would only be half the amount shown, and timing would vary over 50% with the supply variations shown.

Instead, the current regulated LED is still drawing within 10% of full current when the relay reaches its 11 V pull-in voltage. The 14 to 18 V supply variation will produce only about a 3% timing variation, a considerable improvement. Variations due to temperature and electrolytic capacitor tolerances will remain, however.

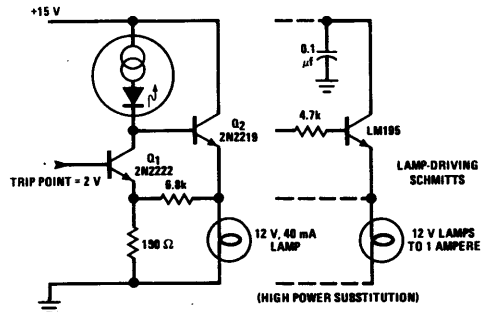


FIGURE 13. Use as Active Load

The lamp-driver Schmitt of Figure 13 illustrates a still further use of the NSL4944's constant current source. Substituting a current source for the collector resistor increases the useful voltage gain of  $Q_1$ . Further, almost full base current remains available to  $Q_2$ , even when supplying 12 V output, which would not be possible using a resistor. When the lamp and  $Q_2$  are off, most of the LED current flows in the 100  $\Omega$  resistor, thus determining the circuit's switching or trip point of 2 V.

With  $Q_1$  saturated,  $Q_2$  still provides a volt to the bulb, contributing some preheating and reducing the bulb's starting current surge. On,  $Q_2$  provides the bulb with 12 V due to the minimum voltage drop in the constant current LED. The 6.8k feedback resistor sets hysteresis at a measured 50 mV at the input. This can be varied without having to change the rest of the circuit. 10k provides almost "0" hysteresis (undesirable and unstable) while 2k sets a hysteresis of 0.5 V.

**CONCLUSION**

A number of applications have been examined for a highly improved two-lead LED/IC. Its indicating capabilities, high reverse voltage, and wide constant current range may make it the most useful of the two-lead, hence simple to use, IC devices. To begin with, it can be lit from AC, unfiltered DC, and very poorly filtered or regulated DC with a savings in parts or size.

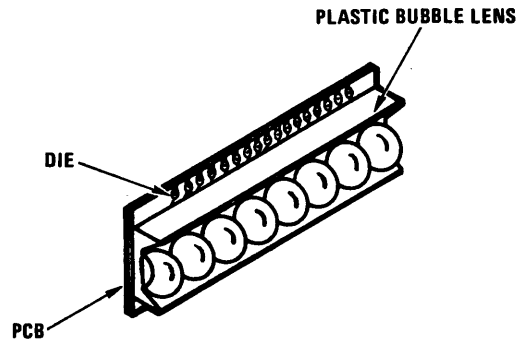
The NSL4944 may be driven from the 1 to 1.5 V swing of TTL circuitry, to the 15 to 18 V swing of Linear and MOS circuits. Its rectifying capabilities allow it to act as

a small battery, charger or reverse voltage monitor for power supplies, batteries, or low voltage SCRs. For all these, and the following functions, the LED "on" indication is in addition to the constant current circuit function performed. The device's constant current can power other LEDs, Zeners, thermistors, or other current or voltage sources. It has been shown that the current regulated LED can be a current limiter, a timing element, or an active load while simplifying and improving circuit performance.



## LED Numeric Arrays

National's LED numeric arrays are PC board mounted, magnified, monolithic, 7-segment red digits arranged in various combinations of up to 14 digits per array. These arrays, with digit heights of 100, 110 and 140 mils (2.54, 2.794 and 3.556 mm) are intended for applications requiring small, low cost numeric indication.



Applications for these devices are no longer limited only to calculator sticks or LED watches. Other applications include:

- Industrial controls
- Data terminals
- Instrumentation
- Timers
- Hand-held instruments
- Event counters

All LED arrays manufactured by National Semiconductor have the prefix NSA.

## LED Numeric Array Selection Guide

Device No.	No. of Digits	Apparent Digit Height	Spacing of Digit Centers	Lens/Magnification	Viewing Angle		Typical Segment Luminous Intensity	Typical Segment Forward Voltage	PCB Length [height 0.72" (18.29 mm)]
					Off Axis	Vert			
NSA0028	2	0.100" (2.54 mm)	0.220" (5.59 mm)	clear, bubble, 2.5 x	21°	23°	0.37 mcd@2.5 mA	1.65V@5 mA	1.10" (27.94 mm)
NSA0038	3	0.100" (2.54 mm)	0.220" (5.59 mm)	clear, bubble, 2.5 x	21°	23°	0.37 mcd@2.5 mA	1.65V@5 mA	1.10" (27.94 mm)
NSA598	9	0.100" (2.54 mm)	0.200" (5.08 mm)	red, flat, 1 x	60°	60°	0.2 mcd@7.0 mA	1.65V@7 mA	2.00" (50.80 mm)
NSA1166	6	0.100" (2.54 mm)	0.200" (5.08 mm)	clear, bubble, 2 x	25°	32°	0.40 mcd@5 mA	1.65V@5 mA	2.00" (5.80 mm)
NSA1188	8	0.100" (2.54 mm)	0.200" (5.08 mm)	clear, bubble, 2.5 x	19°	19°	0.37 mcd@2.5 mA	1.65V@5 mA	2.00" (50.80 mm)
NSA1198	9	0.100" (2.794 mm)	0.200" (5.08 mm)	clear, bubble, 2.5 x	19°	19°	0.37 mcd@2.5 mA	1.65V@5 mA	2.00" (50.80 mm)
NSA1298A	9	0.110" (2.794 mm)	0.200" (5.08 mm)	clear, bubble, 1.8 x	27°	37°	0.23 mcd@3 mA	1.65V@5 mA	2.00" (5.80 mm)
NSA1541A	4	0.140" (3.556 mm)	0.260" (6.604 mm)	clear, bubble, 2 x	25°	32°	0.40 mcd@5 mA	1.65V@5 mA	2.08" (52.83 mm)
NSA1588A	8	0.140" (3.556 mm)	0.260" (6.604 mm)	clear, bubble, 2 x	25°	32°	0.40 mcd@5 mA	1.65V@5 mA	2.08" (52.83 mm)
NSA5140A	14	0.110" (2.794 mm)	0.150" (3.81 mm)	clear, bubble, 1.5 x	25°	34°	0.45 mcd@7 mA	1.8V@7 mA	2.38" (60.45 mm)
NSA7120	12	0.110" (2.794 mm)	0.175" (4.445 mm)	clear, bubble, 2 x	20°	20°	0.35 mcd@5 mA	1.8V@5 mA	2.375" (60.32 mm)

## LED Numeric Array Cross Reference

Part Number	Description	NSC Device	Notes
<b>Hewlett-Packard</b>			
5082-7240	0.102" (2.59 mm) 8-digit array	NSA1188	E
5082-7241	0.102" (2.59 mm) 9-digit array	NSA1198	E
5082-7442	0.100" (2.54 mm) 12-digit array	NSA7120	B
5082-7444	0.100" (2.54 mm) 14-digit array	NSA5140A	B, C, D, E
5082-7447	0.112" (2.85 mm) 14-digit array	NSA5140A	C, D, E
<b>Texas Instruments</b>			
TIL379-12	0.106" (2.69 mm) 12-digit array	NSA7120	D
TIL393-8	0.102" (2.59 mm) 8-digit array	NSA1188	A
TIL393-9	0.102" (2.59 mm) 9-digit array	NSA1198	A

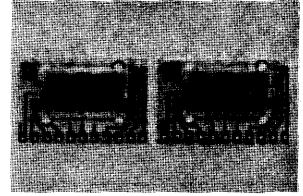
**Notes:** A—Direct replacement

B—Minor difference in digit size

C—Minor difference in PC board length

D—Difference in pin out

E—Difference in pin location



## NSA0028, NSA0038 0.100 Inch (2.54 mm) LED Numeric Arrays

### General Description

The NSA0038 is a 3-digit monolithic GaAsP PC board mounted numeric array. Each digit comprises 7 segments plus right hand decimal point. The array is common cathode and the anodes are internally connected for multiplexing. Simple interface circuits may be used for TTL, DTL or MOS operation.

The NSA0028 is a 2-digit version of the NSA0038.

The clear lens of the array package provides excellent light transmission and visibility over a wide angle.

PC board type terminals allow easy connection by wire or pin soldering or with a card-edge connector. The thin package allows significant size reduction for high density electronic equipment.

### Applications

- Timers
- Event counters
- Digital instruments

- Industrial controls
- Data terminals
- Instrumentation
- Electronic test and measurement equipment
- Microprocessor based systems

### Absolute Ratings

Average Current per Segment	0.25 mA min, 7.0 mA max
Peak Current per Segment	2.5 mA min, 70 mA max
Reverse Voltage	3.0V min
Digit Current Pulse Width	1.0 ms max
Operating and Storage Temperatures	-20°C to +70°C
Relative Humidity at 35°C	98% max
Terminal Temperature (Soldering, 5 seconds)	230°C max

### Electrical and Optical Characteristics $T_A = 25^\circ\text{C}$ Room Temperature

PARAMETER	CONDITIONS	MIN	TYP	MAX	UNITS
Segment Light Intensity (Peak)	2.5 mA/Seg. Peak	0.16	0.37		mcd
Digit Light Intensity (Peak)	2.5 mA/Seg. Peak	1.28	2.96		mcd
Segment Forward Voltage	5.0 mA/Seg. DC		1.65	2.0	V
Reverse Voltage	100 $\mu$ A/Seg.	3.0	8.0		V
Intensity Matching			$\pm 33$		%
Peak Wavelength			660		nm
Spectral Width, Half Intensity			40		nm
Viewing Angle, Off Axis, Horizontal	Axial Point		21		Degrees
Viewing Angle, Off Axis, Vertical	Axial Point		23		Degrees

## Recommended Numeric Array Processing

The NSA0028, NSA0038 array is constructed on a standard printed circuit board substrate and covered with a plastic lens.

The edge connector tab will stand a temperature of 230°C for 5 seconds.

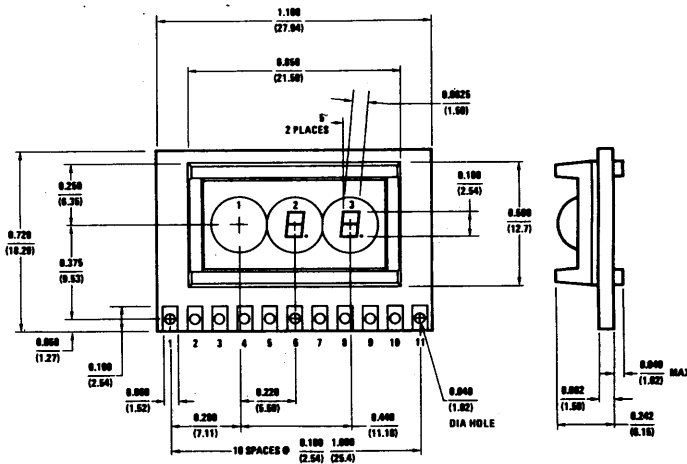
The display lens area must not be elevated in temperature above 70°C. To do so will result in permanent damage to the display.

It is recommended that only localized cleaning with a cotton swab on external surfaces be performed after soldering.

Only rosin core solder, solid core solder and low temperature deactivating fluxes are recommended. Recommended post solder cleaning solvents are Freon TF, Isopropanol, Methanol or Ethanol. These solvents are recommended only at room temperature and short time periods.

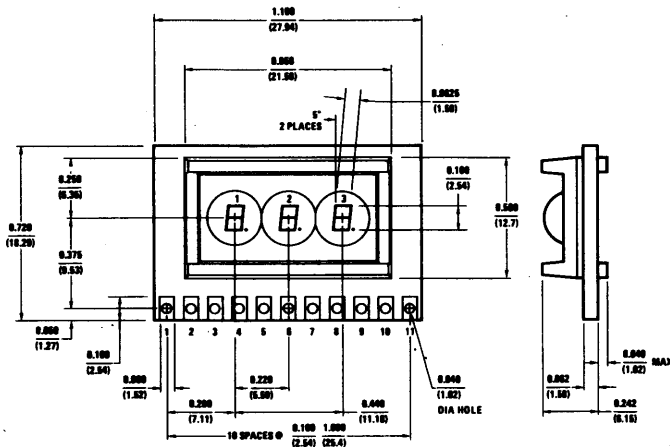
The use of other solvents or elevated temperature use of the recommended solvents may cause permanent damage to the lens or the display.

## Physical Dimensions and Pin Connections inches (millimeters)



Order Number NSA0028

PIN NO.	ELECTRICAL CONNECTION
1	NC
2	Digit 2 Cathode
3	Segment E Anode
4	Segment C Anode
5	Segment D Anode
6	NC
7	Digit 3 Cathode
8	Segment G Anode
9	Segment F Anode
10	Segment B Anode
11	Segment A Anode



Order Number NSA0038

PIN NO.	ELECTRICAL CONNECTION
1	Digit 1 Cathode
2	Digit 2 Cathode
3	Segment E Anode
4	Segment C Anode
5	Segment D Anode
6	Segment DP Anode
7	Digit 3 Cathode
8	Segment G Anode
9	Segment F Anode
10	Segment B Anode
11	Segment A Anode

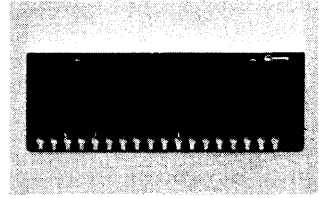
### Segment Designation



5° Segment Angle

Note 1: Material: superpunch or approved equivalent.

Note 2: All tolerances  $\pm 0.015$  / (0.38).



## NSA500 Series 0.100 Inch (2.54 mm) LED Numeric Arrays

### General Description

The NSA500 series features a 0.100 inch non-magnified monolithic digit with extremely wide viewing angle. These devices are common cathode GaAsP LED's with each digit comprised of seven segments with right hand decimal point. Eight inputs are provided for selection of the appropriate segment and decimal (anodes) and separate inputs for digit (cathodes) selection. The anodes are internally interconnected for multiplexing. Simple interface circuits may be used for TTL, DTL, or MOS operation.

The red faceplate of the display package provides excellent visual contrast and ease of visibility.

### Applications

- Digital instruments
- Industrial controls
- Data terminals

- Instrumentation
- Electronic test and measurement equipment
- Clocks and timers
- Hand-held calculators
- Desk calculators

### Absolute Ratings

Average Current per Segment	0.7mA min, 5.0mA max
Peak Current per Segment	7.0mA min, 60mA max
Reverse Voltage	3.0V max.
Operating and Storage Temperatures	-20°C to +70°C
Relative Humidity at +35°C	98% max.
Terminal Temperature (Soldering, 5 seconds)	230°C max.

### Electrical and Optical Characteristics $T_A = +25^\circ\text{C}$ Room Temperature

PARAMETER	CONDITIONS	MIN	TYP	MAX	UNITS
Segment Light Intensity (Peak)	7.0mA/Segment Peak	0.07	0.2		mcd
Digit Light Intensity (Peak)	7.0mA/Segment Peak	0.56	1.6		mcd
Segment Forward Voltage	7.0mA/Segment DC		1.65	2.0	V
Reverse Voltage	100 $\mu$ A/Segment	3.0	8.0		V
Intensity Matching			$\pm 33$		%
Peak Wavelength			660		nm
Spectral Width, Half-intensity			40		nm
Viewing Angle, Off Axis, Horizontal	Undistorted		$\pm 60$		degrees



## Custom Options NSA500 Series

- Number of digits, 6-9
- Number of decimal points, maximum of 9
- Minus signs can be substituted in place of any digit. Address line will be Segment G
- A decimal point and/or colon can be substituted for any digit and placed in any segment position (Will be electrically connected to that segment address line)
- For all variations from the standard products it is recommended the factory be contacted

The display lens area must not be elevated in temperature above 70°C. To do so will result in permanent damage to the display.

It is recommended that the back of the display be masked off with low tac masking tape during flux and clean operations, to prevent condensation of flux or cleaner on the underside of the lens.

It is also recommended that only localized cleaning with a cotton swab on external surfaces be performed after soldering.

Only rosin core solder, solid core solder and low temperature deactivating flux are recommended. Recommended post solder clean solvents are Freon TF, Isopropanol, Methanol or Ethanol. These solvents are recommended only at room temperature and short time periods.

The use of other solvents or elevated temperature use of the recommended solvents may cause permanent damage to the lens or the display.

There are a number of edge connectors which can also be used with these display.

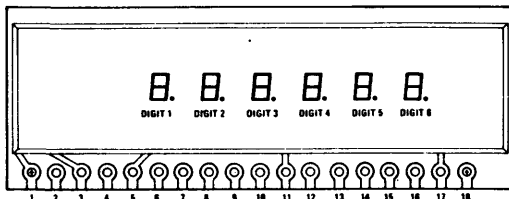
## Recommended Numeric Array Processing

The NSA500 Series arrays are constructed on a standard printed circuit board substrate and covered with a plastic lens.

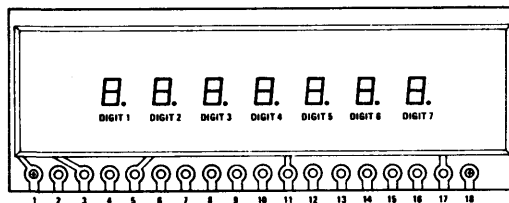
The edge connectors tab will stand a temperature of 230°C for 5 seconds.

## Standard Digit Positions

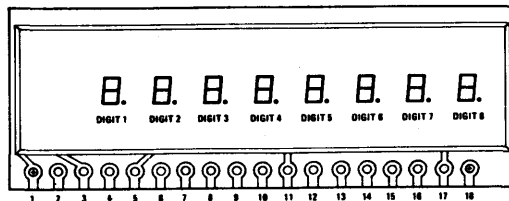
NSA568\*



NSA578\*



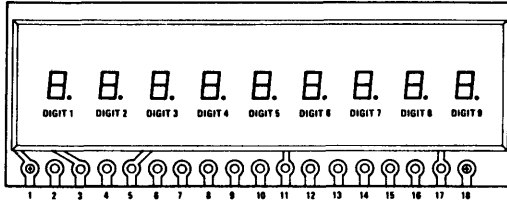
NSA588\*



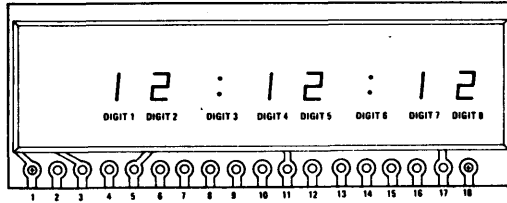
\* Built to order only. For small quantities, use NSA598.

Standard Digit Positions (Continued)

NSA598



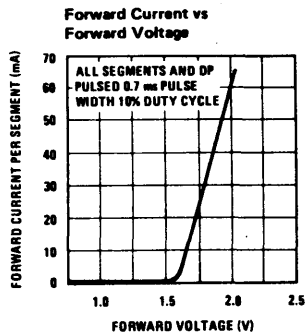
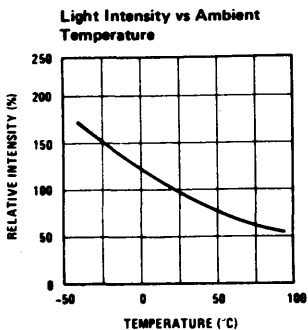
TYPICAL CLOCK VARIATION



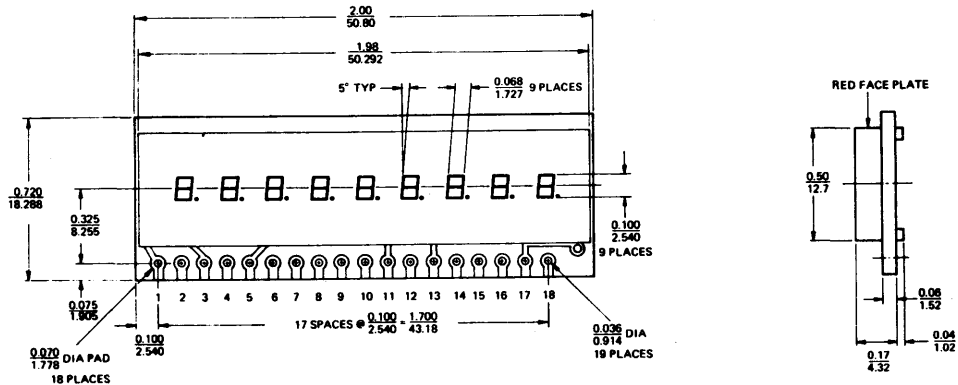
Connections Table

PIN CONNECTIONS	NSA568	NSA578	NSA588	NSA598	ANODE OR CATHODE
1	NC	NC	NC	NC	No Connection
2	NC	NC	NC	Digit 1	Cathode
3	Segment C	Segment C	Segment C	Segment C	Anode
4	NC	Digit 1	Digit 1	Digit 2	Cathode
5	D.P.	D.P.	D.P.	D.P.	Anode
6	Digit 1	Digit 2	Digit 2	Digit 3	Cathode
7	Segment A	Segment A	Segment A	Segment A	Anode
8	Digit 2	Digit 3	Digit 3	Digit 4	Cathode
9	Segment E	Segment E	Segment E	Segment E	Anode
10	Digit 3	Digit 4	Digit 4	Digit 5	Cathode
11	Segment D	Segment D	Segment D	Segment D	Anode
12	Digit 4	Digit 5	Digit 5	Digit 6	Cathode
13	Segment G	Segment G	Segment G	Segment G	Anode
14	Digit 5	Digit 6	Digit 6	Digit 7	Cathode
15	Segment B	Segment B	Segment B	Segment B	Anode
16	Digit 6	Digit 7	Digit 7	Digit 8	Cathode
17	Segment F	Segment F	Segment F	Segment F	Anode
18	NC	NC	Digit 8	Digit 9	Cathode

Typical Performance Characteristics (25°C)



Physical Dimensions and Pin Connections inches (millimeters)



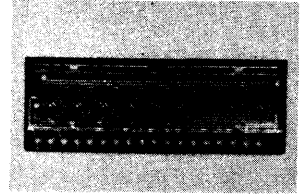
Note 1: Material: Super punch circuit board or approved equivalent.

Note 2: 9 digits on 0.200/(5.080) centers.

Order Number NSA598 for 9-digit unit  
Special numbers are assigned for Custom Units NSA5XX

Segment Designation





## NSA1100 Series 0.100 Inch (2.54 mm) 9-Digit LED Numeric Arrays

### General Description

The NSA1100 Series uses monolithic digits and can have up to nine digits. These devices are common cathode GaAsP LED, with an apparent 0.100 inch character height. Each digit comprises 7-segments with a right hand decimal point. Eight inputs are provided for selection of the appropriate segments and decimal (anodes) and separate inputs for digit (cathodes) selection. The anodes are internally interconnected for multiplexing. Simple interface circuits may be used for TTL, DTL, or MOS operation.

The clear lens of the display package provides excellent light transmission and ease of visibility over a wide angle. The package is also designed to be readily incorporated into the system. PC board type terminals allow easy connection by wire or pin soldering or with cardedge connector. The thin package allows significant size reduction for high density electronic equipment. These devices are designed to be used with a clear red filter.

### Applications

- Hand held calculators
- Desk calculators
- Digital instruments
- Industrial controls
- Data terminals
- Instrumentation
- Electronic test and measurement equipment

### Absolute Ratings

Average Current per Segment	0.25 mA min, 7.0 mA max
Peak Current per Segment	2.5 mA min, 70 mA max
Reverse Voltage	3.0V max
Digit Current Pulse Width	1.0 ms max
Operating and Storage Temperatures	-20°C to +70°C
Relative Humidity at +35°C	98% max
Terminal Temperature (Soldering, 5 seconds)	230°C max

### Electrical and Optical Characteristics $T_A = 25^\circ\text{C}$ Room Temperature

PARAMETER	CONDITIONS	MIN	TYP	MAX	UNITS
Segment Light Intensity (Peak)	2.5 mA/Segm. Peak	0.16	0.37		mcd
Segment Forward Voltage	5.0 mA/Segm. dc		1.65	2.0	V
Reverse Voltage	100 $\mu\text{A}$ /Segm.	3.0	8.0		V
Intensity Matching			$\pm 33$		%
Peak Wavelength			660		nm
Spectral Width, Half-Intensity			40		nm
Viewing Angle, Off Axis, Horizontal			19		degrees
Viewing Angle, Off Axis, Vertical			19		degrees

## Custom Options NSA11XX

- Number of digits, 6-9
- Number of decimal points, maximum of 9.
- Minus signs can be substituted in place of any digit Address line will be Segment G
- A decimal point can be substituted for any digit and placed in any segment position (Will be electrically connected to that segment address line)
- For all variations from the standard products it is recommended the factory be contacted

## Recommended Numeric Array Processing

The NSA1100 Series arrays are constructed on a standard printed circuit board substrate and covered with a plastic lens.

The edge connectors tab will stand a temperature of 230°C for 5 seconds.

The display lens area must not be elevated in temperature above 70°C. To do so will result in permanent damage to the display.

It is recommended that the back of the display be masked off with low tac masking tape during flux and clean operations, to prevent condensation of flux or cleaner on the underside of the lens.

It is also recommended that only localized cleaning with a cotton swab on external surfaces be performed after soldering.

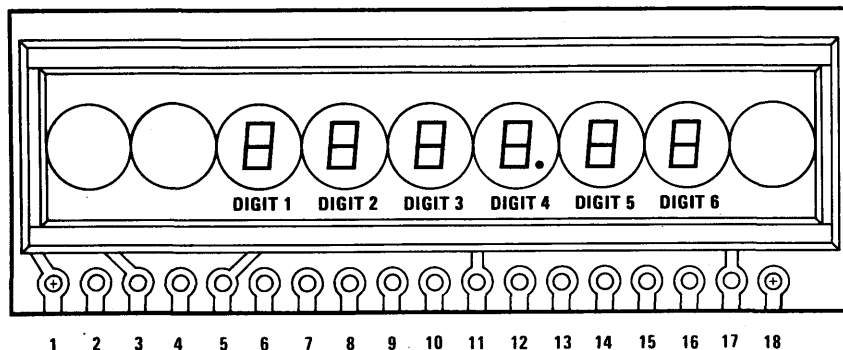
Only rosin core solder, solid core solder and low temperature deactivating flux are recommended. Recommended post solder clean solvents are Freon TF, Isopropanol, Methanol or Ethanol. These solvents are recommended only at room temperature and short time periods.

The use of other solvents or elevated temperature use of the recommended solvents may cause permanent damage to the lens or the display.

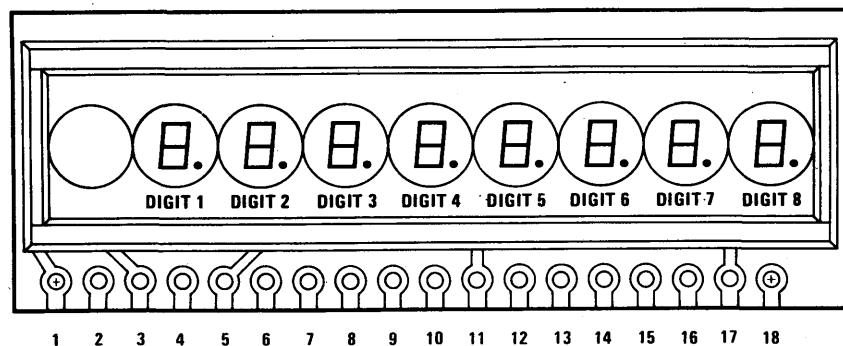
There are a number of edge connectors which can also be used with these displays.

## Standard Digit Positions

NSA1166



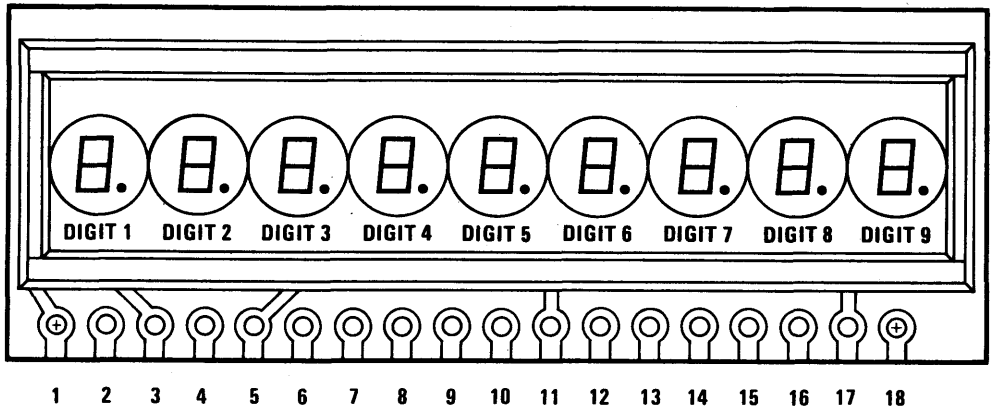
NSA1188\*



\* Built on special order only. Use NSA1198 for small quantity requirements.

## Standard Digit Positions (Continued)

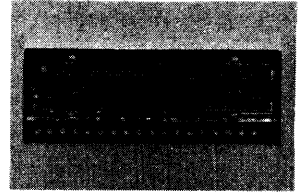
NSA1198



## Connections Table

PIN CONNECTIONS	NSA1188	NSA1198	ANODE OR CATHODE
1	NC	NC	No Connection
2	NC	Digit 1	Cathode
3	Segment C	Segment C	Anode
4	Digit 1	Digit 2	Cathode
5	D.P.	D.P.	Anode
6	Digit 2	Digit 3	Cathode
7	Segment A	Segment A	Anode
8	Digit 3	Digit 4	Cathode
9	Segment E	Segment E	Anode
10	Digit 4	Digit 5	Cathode
11	Segment D	Segment D	Anode
12	Digit 5	Digit 6	Cathode
13	Segment G	Segment G	Anode
14	Digit 6	Digit 7	Cathode
15	Segment B	Segment B	Anode
16	Digit 7	Digit 8	Cathode
17	Segment F	Segment F	Anode
18	Digit 8	Digit 9	Cathode





## NSA1298A 0.110 Inch (2.794 mm) 9-Digit LED Numeric Array

### general description

The NSA1298A is a monolithic, nine digit common cathode GaAsP LED numeric array with an apparent 0.110 inch character height. Each digit comprises 7-segments with a right hand decimal point. Eight inputs are provided for selection of the appropriate segments and decimal (anodes) and nine inputs for digit (cathodes) selection. The anodes are internally interconnected for multiplexing. Simple interface circuits may be used for TTL, DTL, or MOS operation.

The clear lens of the display package provides excellent light transmission and ease of visibility over a wide angle. The package is also designed to be readily incorporated into the system. PC board type terminals allow easy connection by wire or pin soldering or with cardedge connector. The thin package allows significant size reduction for high density electronic equipment.

### applications

- Hand held calculators
- Desk calculators
- Digital instruments
- Industrial controls
- Data terminals
- Instrumentation
- Electronic test and measurement equipment

### absolute ratings

Average Current per Segment	0.3 mA min, 7.0 mA max
Peak Current per Segment	3.0 mA min, 70 mA max
Reverse Voltage	3.0V max
Digit Current Pulse Width	1.0 ms max
Operating and Storage Temperatures	-20°C to +70°C
Relative Humidity at +35°C	98%
Terminal Temperature (Soldering; 5 seconds)	230°C max

### electrical and optical characteristics $T_A = +25^\circ\text{C}$ Room Temperature

PARAMETER	CONDITIONS	MIN	TYP	MAX	UNITS
Segment Light Intensity (Peak)	3.0 mA/Segm. Peak	0.10	0.23		mcd
Digit Light Intensity (Peak)	3.0 mA/Segm. Peak	0.80	1.84		mcd
Segment Forward Voltage	5.0 mA/Segm. dc		1.65	2.0	V
Reverse Voltage	100 $\mu$ A/Segm.	3.0	8.0		V
Intensity Matching			$\pm 33$		%
Peak Wavelength			660		nm
Spectral Width, Half-Intensity			40		nm
Viewing Angle, Off Axis, Horizontal			21		degrees
Viewing Angle, Off Axis, Vertical			22		degrees



### custom options NSA12XX

- Number of digits, 6-9
- Number of decimal points, maximum of 9
- Minus signs can be substituted in place of any digit  
Address line will be Segment G
- A decimal point can be substituted for any digit and placed in any segment position. (Will be electrically connected to that segment address line)
- For all other variations it is recommended the factory be contacted

### recommended display array processing

The NSA1298A display is constructed on a standard printed circuit board substrate and covered with a plastic lens.

The edge connectors tab will stand a temperature of 230°C for 5 seconds.

The display lens area must not be elevated in temperature above 70°C. To do so will result in permanent damage to the display.

It is recommended that the back of the display be masked off with low tac masking tape during flux and clean operations, to prevent condensation of flux or cleaner on the underside of the lens.

Only rosin core solder, solid core solder and low temperature deactivating flux are recommended. Recommended post solder clean solvents are Freon TF, Isopropanol, Methanol or Ethylene. These solvents are recommended only at room temperature and short time periods.

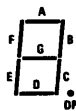
The use of other solvents or elevated temperature use of the recommended solvents may cause permanent damage to the lens or the display.

### physical dimensions and pin connections inches (millimeters)

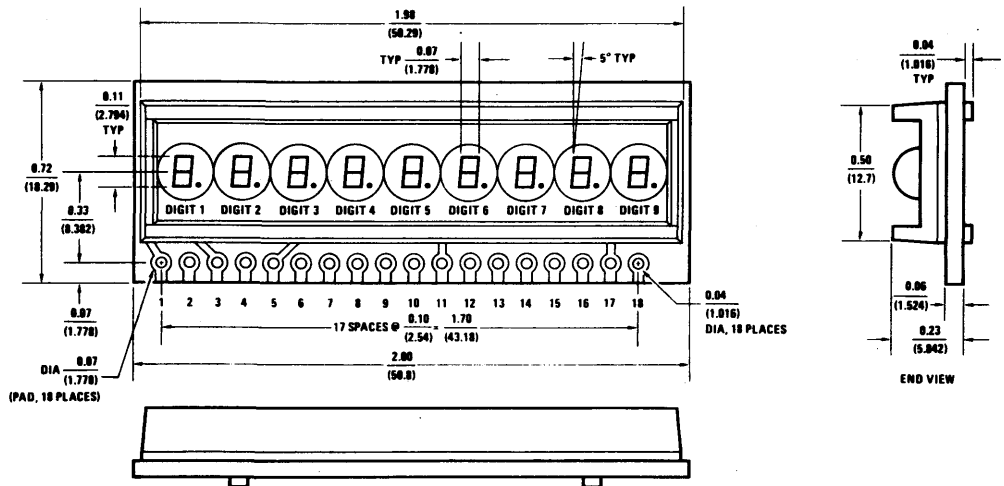
Pin Connections

Pin 1 NC	Pin 16 Digit 5 Cathode
Pin 2 Digit 1 Cathode	Pin 11 Segment D Anode
Pin 3 Segment C Anode	Pin 12 Digit 6 Cathode
Pin 4 Digit 2 Cathode	Pin 13 Segment G Anode
Pin 5 Segment DP Anode	Pin 14 Digit 7 Cathode
Pin 6 Digit 3 Cathode	Pin 15 Segment B Anode
Pin 7 Segment A Anode	Pin 16 Digit 8 Cathode
Pin 8 Digit 4 Cathode	Pin 17 Segment F Anode
Pin 9 Segment E Anode	Pin 18 Digit 9 Cathode

Segment Designation



ALL DIGITS ON 0.20 INCH CENTER



Note 1: Material: G-10 circuit board, natural or approved equivalent  
 Note 2: Nine digits on 0.200/5.08 centers.

Order Number NSA1298A  
 Special Numbers Are Assigned for Custom Units NSA12XX



# National Semiconductor

## NSA1541A 0.140 Inch (3.556 mm) 4-Digit LED Numeric Array



### General Description

The NSA1541A is a 4-digit end-stackable common cathode GaAsP LED numeric array with an apparent 0.140 inch character height. Each digit comprises 7 segments with a right hand decimal point. Eight inputs are provided for selection of the appropriate segments and decimal (anodes) and 4 inputs for digit (cathodes) selection. The anodes are internally interconnected for multiplexing. Simple interface circuits may be used for TTL, DTL, or MOS operation.

The clear lens of the display package provides excellent light transmission and visibility over a wide angle. The package is also designed to be readily incorporated into the system. PC board type terminals allow easy connection by wire or pin soldering or with a card-edge connector. The thin package allows significant size reduction for high density electronic equipment.

### Features

- Low drive current
- Direct drive from MOS
- Wide viewing angle

### Applications

- Digital instruments
- Industrial controls
- Data terminals
- Instrumentation
- Electronic test and measurement equipment

### Absolute Ratings

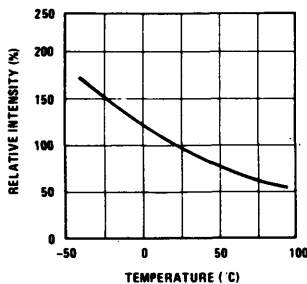
Average Current per Segment	0.25 mA min, 7.0 mA max
Peak Current per Segment	2.5 mA min, 70 mA max
Reverse Voltage	3.0V max
Digit Current Pulse Width	1 ms max
Operating and Storage Temperature	-20°C to +70°C
Relative Humidity at 35°C	98% max
Terminal Temperature (Soldering, 5 seconds)	230°C max

### Electrical and Optical Characteristics $T_A = 25^\circ\text{C}$ Room Temperature

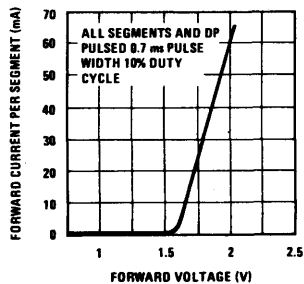
PARAMETER	CONDITIONS	MIN	TYP	MAX	UNITS
Segment Light Intensity (Peak)	5 mA/Segment Peak	0.15	0.40		mcd
Segment Forward Voltage	5 mA/Segment DC		1.65	2.0	V
Reverse Voltage	100 $\mu\text{A}$ /Segment	3.0	8.0		V
Intensity Matching			$\pm 33$		%
Peak Wavelength			660		nm
Special Width, Half-Intensity			40		nm
Viewing Angle, Off Axis, Horizontal			25		Degrees
Viewing Angle, Off Axis, Vertical			32		Degrees

### Typical Performance Characteristics (25°C)

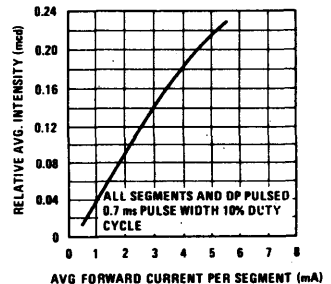
Light Intensity vs Ambient Temperature



Forward Current vs Forward Voltage



Average Light Intensity vs Average Forward Current



## Recommended Display Array Processing

The NSA1541A array is constructed on a standard printed circuit board substrate and covered with a plastic lens.

The edge connector's tab will stand a temperature of 230°C for 5 seconds.

The display lens area must not be elevated in temperature above 70°C. To do so will result in permanent damage to the display.

It is recommended that the back of the display be masked off with low tac masking tape during flux and clean operations, to prevent condensation of flux or cleaner on the underside of the lens.

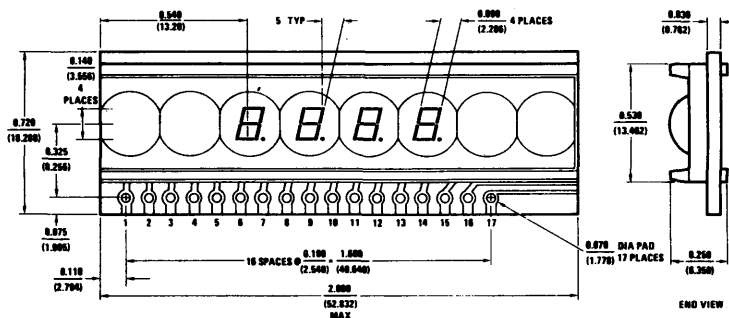
It is also recommended that only localized cleaning with a cotton swab on external surfaces be performed after soldering.

Only rosin core solder, solid core solder and low temperature deactivating flux are recommended. Recommended post solder cleaning solvents are Freon TF, Isopropanol, Methanol or Ethanol. These solvents are recommended only at room temperature and for short time periods.

The use of other solvents or elevated temperature use of the recommended solvents may cause permanent damage to the lens or the display.

There are a number of edge connectors which can also be used with this display.

## Physical Dimensions and Pin Connections inches (millimeters)



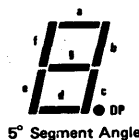
PIN	CONNECTION
1	No Connection
2	Segment c Anode
3	No Connection
4	Segment DP Anode
5	No Connection
6	Segment a Anode
7	Digit 1 Cathode
8	Segment e Anode
9	Digit 2 Cathode
10	Segment d Anode
11	Digit 3 Cathode
12	Segment g Anode
13	Digit 4 Cathode
14	Segment b Anode
15	No Connection
16	Segment f Anode
17	No Connection

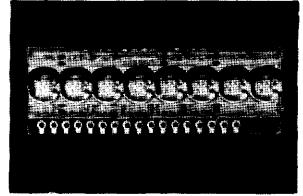
Note 1: Material PC-75 circuit board or approved equivalent.

Note 2: 4 digits on 0.260/(6.604) centers.

Order Number NSA1541A

### Segment Designation





## NSA1588A 0.140 Inch (3.556 mm) 8-Digit LED Numeric Array

### General Description

The NSA1588A is an 8-digit, end stackable, common cathode GaAsP LED numeric array with an apparent 0.140 inch character height. Each digit comprises 7 segments with a right hand decimal point. Eight inputs are provided for selection of the appropriate segments and decimal (anodes) and 8 inputs for digit (cathodes) selection. The anodes are internally interconnected for multiplexing. Simple interface circuits may be used for TTL, DTL or MOS operation.

The clear lens of the array package provides excellent light transmission and visibility over a wide angle. The package is also designed to be readily incorporated into the system. PC board type terminals allow easy connection by wire or pin soldering or with a card-edge connector. The thin package allows significant size reduction for high density electronic equipment.

### Features

- Low drive current
- Direct drive from MOS
- Wide viewing angle

### Applications

- Digital instruments
- Industrial controls
- Data terminals
- Instrumentation
- Electronic test and measurement equipment

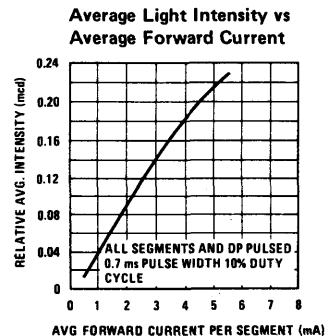
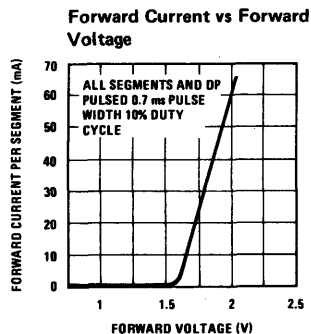
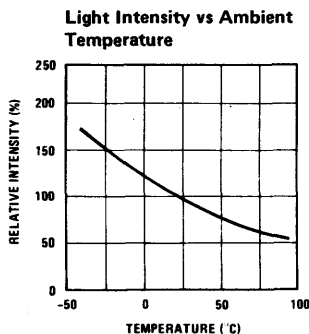
### Absolute Ratings

Average Current per Segment	0.25 mA min, 7.0 mA max
Peak Current per Segment	2.5 mA min, 70 mA max
Reverse Voltage	3.0V max
Digit Current Pulse Width	1 ms max
Operating and Storage Temperature	-20°C to +70°C
Relative Humidity at 35°C	98% max
Terminal Temperature (Soldering, 5 seconds)	230°C max

### Electrical and Optical Characteristics $T_A = 25^\circ\text{C}$ Room Temperature

PARAMETER	CONDITIONS	MIN	TYP	MAX	UNITS
Segment Light Intensity (Peak)	5 mA/Segment Peak	0.15	0.40		mcd
Segment Forward Voltage	5 mA/Segment DC		1.65	2.0	V
Reverse Voltage	100 $\mu\text{A}$ /Segment	3.0	8.0		V
Intensity Matching			$\pm 33$		%
Peak Wavelength			660		nm
Special Width, Half-Intensity			40		nm
Viewing Angle, Off Axis, Horizontal			25		Degrees
Viewing Angle, Off Axis, Vertical			32		Degrees

### Typical Performance Characteristics (25°C)



## Custom Options NSA15XX Series

- Number of digits, 6-8
- Number of decimal points, maximum of 8
- Minus signs can be substituted in place of any digit. Address line will be segment g
- A decimal point can be substituted for any digit and placed in any segment position (will be electrically connected to that segment address line)
- For all variations from the standard products it is recommended the factory be contacted

## Recommended Numeric Array Processing

The NSA1588A array is constructed on a standard printed circuit board substrate and covered with a plastic lens.

The edge connector's tab will stand a temperature of 230°C for 5 seconds.

The display lens area must not be elevated in temperature above 70°C. To do so will result in permanent damage to the display.

It is recommended that the back of the display be masked off with low tac masking tape during flux and clean operations, to prevent condensation of flux or cleaner on the underside of the lens.

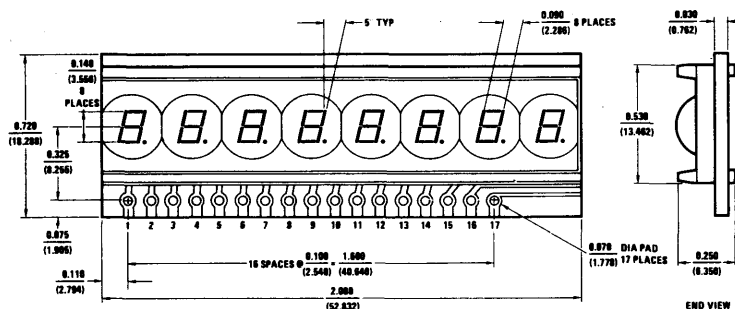
It is also recommended that only localized cleaning with a cotton swab on external surfaces be performed after soldering.

Only rosin core solder, solid core solder and low temperature deactivating flux are recommended. Recommended post solder cleaning solvents are Freon TF, Isopropanol, Methanol or Ethanol. These solvents are recommended only at room temperature and for short time periods.

The use of other solvents or elevated temperature use of the recommended solvents may cause permanent damage to the lens or the display.

There are a number of edge connectors which can also be used with this display.

## Physical Dimensions and Pin Connections inches (millimeters)



PIN	CONNECTION
1	No Connection
2	Segment c Anode
3	Digit 1 Cathode
4	Segment DP Anode
5	Digit 2 Cathode
6	Segment a Anode
7	Digit 3 Cathode
8	Segment e Anode
9	Digit 4 Cathode
10	Segment d Anode
11	Digit 5 Cathode
12	Segment g Anode
13	Digit 6 Cathode
14	Segment b Anode
15	Digit 7 Cathode
16	Segment f Anode
17	Digit 8 Cathode

Note 1: Material PC-75 circuit board or approved equivalent.

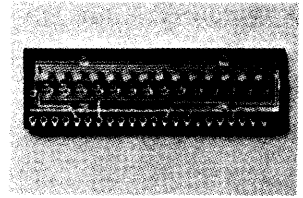
Note 2: 8 digits on 0.260/(6.604) centers.

Order Number NSA1588A

### Segment Designation



5° Segment Angle


**National  
Semiconductor**
**NSA5140A 0.110 Inch (2.79 mm) 14-Digit  
LED Numeric Array**

**General Description**

The NSA5140A is a fourteen monolithic digit common cathode GaAsP, LED numeric array with an apparent 0.110 inch (2.79mm) character height. Each digit comprises seven segments with a right hand decimal point. Eight inputs are provided for selection of the appropriate segments and decimal (anodes) and fourteen inputs for digit (cathodes) selection. The anodes are internally interconnected for multiplexing. Simple interface circuits may be used for TTL, DTL, or MOS operation.

The clear lens of the display package provides excellent light transmission and ease of visibility over a wide angle. The package is also designed to be readily incorporated into the system. PC board type terminals allow easy connection by wire or pin soldering or with a card-edge connector. The thin package allows significant size reduction for high density electronic equipment.

The excellent aspect ratio of the digit [0.110 x 0.070/ (2.79 x 1.78)] affords added versatility for the designer to further magnify the display digit height.

**Applications**

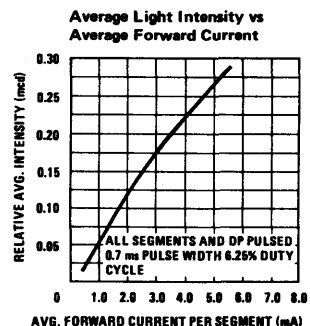
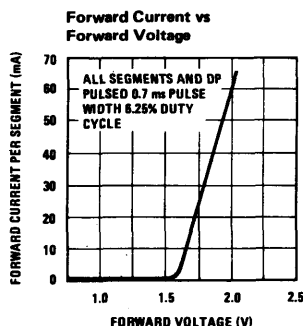
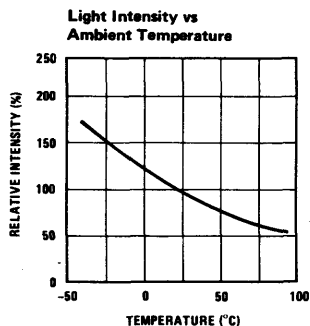
- Hand held calculators
- Desk calculators
- Digital instruments
- Industrial controls
- Data terminals
- Instrumentation
- Electronic test and measurement equipment

**Absolute Ratings**

Average Current per Segment	0.5 mA min, 20 mA max
Peak Current per Segment	7.0 mA min, 70 mA max
Reverse Voltage	3.0V max
Digit Current Pulse Width	1.0 ms max
Operating and Storage Temperatures	-20°C to +70°C
Relative Humidity at +35°C	98% max
Terminal Temperature (Soldering, 5 seconds)	230°C max

**Electrical and Optical Characteristics**  $T_A = +25^\circ\text{C}$  Room Temperature

PARAMETER	CONDITIONS	MIN	TYP	MAX	UNITS
Segment Light Intensity (Peak)	7.0 mA/Segm. Peak	0.15	0.45		mcld
Segment Forward Voltage	7.0 mA/Segm. DC		1.8	2.0	V
Reverse Voltage	100 $\mu$ A/Segm.	3.0	8.0		V
Intensity Matching			$\pm 33$		%
Peak Wavelength			660		nm
Spectral Width, Half-Intensity			40		nm
Viewing Angle, Off Axis, Horiz.			25		degrees
Viewing Angle, Off Axis, Vert.			34		degrees

**Typical Performance Characteristics (25°C)**


## Custom Options NSA51XX

Custom options are available as follows:

- Number of digits, 9 through 14.
- Number of decimal points. Maximum of 14.
- Minus signs can be substituted in place of any digit. Address line will be Segment G.
- A decimal point can be substituted for any digit and placed in any segment position. (Will be electrically connected to that segment address line.)
- For all other variations it is recommended the factory be contacted.

## Recommended Display Array Processing

The NSA5140A display is constructed on a standard printed circuit board substrate and covered with a plastic lens.

The edge connectors tab will stand a temperature of 230°C for 5 seconds.

The display lens area must not be elevated in temperature above 70°C. To do so will result in permanent damage to the display.

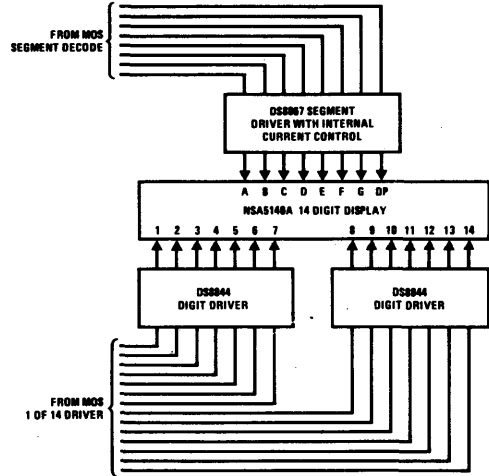
It is recommended that the back of the display be masked off with low tac masking tape during flux and clean operations, to prevent condensation of flux or cleaner on the underside of the lens.

It is also recommended that only localized cleaning with a cotton swab on external surfaces be performed after soldering.

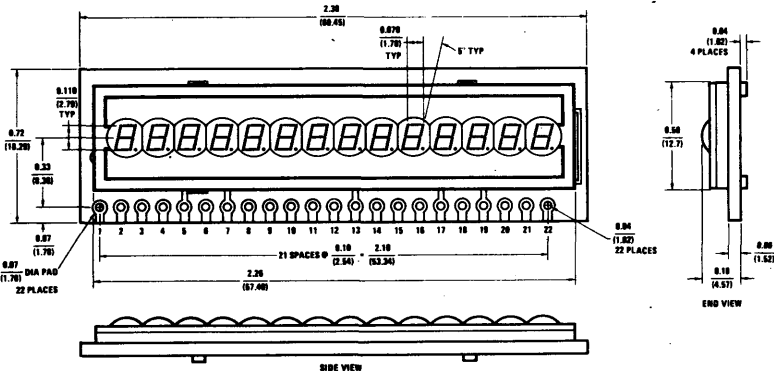
Only rosin core solder, solid core solder and low temperature deactivating fluxes are recommended. Recommended post solder clean solvents are Freon TF, Isopropanol, Methanol or Ethanol. These solvents are recommended only at room temperature and short time periods.

The use of other solvents or elevated temperature use of the recommended solvents may cause permanent damage to the lens or the display.

## Typical Drive Circuit



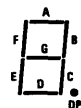
## Physical Dimensions and Pin Connections inches (millimeters)



### Pin Connections

- PIN 1 DIGIT 1 CATHODE
- PIN 2 DIGIT 2 CATHODE
- PIN 3 DIGIT 3 CATHODE
- PIN 4 DIGIT 4 CATHODE
- PIN 5 SEGMENT C ANODE
- PIN 6 DIGIT 5 CATHODE
- PIN 7 SEGMENT DP ANODE
- PIN 8 DIGIT 6 CATHODE
- PIN 9 SEGMENT A ANODE
- PIN 10 DIGIT 7 CATHODE
- PIN 11 SEGMENT E ANODE
- PIN 12 DIGIT 8 CATHODE
- PIN 13 SEGMENT D ANODE
- PIN 14 DIGIT 9 CATHODE
- PIN 15 SEGMENT G ANODE
- PIN 16 DIGIT 10 CATHODE
- PIN 17 SEGMENT B ANODE
- PIN 18 DIGIT 11 CATHODE
- PIN 19 SEGMENT F ANODE
- PIN 20 DIGIT 12 CATHODE
- PIN 21 DIGIT 13 CATHODE
- PIN 22 DIGIT 14 CATHODE

### Segment Designation



All digits on 0.15 (3.81) centers

**Note 1:** Material: PC-75 circuit board or approved equivalent.

**Note 2:** All dimensions in inches and (millimeters).

**Note 3:** Fourteen digits on 0.150/(3.81) centers.

**Note 4:** All tolerances ±0.015 (0.38).

Order Number NSA5140A for 14-Digit Unit  
Special Numbers are Assigned for Custom Units NSA51XX



## NSA7120 0.110 Inch (2.794 mm) 12-Digit LED Numeric Array

### General Description

The NSA7120 is a 12 monolithic digit common cathode GaAsP, LED numeric array with an apparent 0.110 inch (2.79 mm) character height. Each digit comprises 7 segments with a right hand decimal point. Eight inputs are provided for selection of the appropriate segments and decimal (anodes) and 12 inputs for digit (cathodes) selection. The anodes are internally interconnected for multiplexing. Simple interface circuits may be used for TTL, DTL, or MOS operation.

The clear lens of the array package provides excellent light transmission and ease of visibility over a wide angle. The package is also designed to be readily incorporated into the system. PC board type terminals allow easy connection by wire or pin soldering or with a card-edge connector. The thin package allows significant size reduction for high density electronic equipment.

The excellent aspect ratio of the digit [0.110 x 0.070/ (2.79 x 1.78)] affords added versatility for the designer to further magnify the display digit height.

### Applications

- Hand-held calculators
- Desk calculators
- Digital instruments
- Industrial controls
- Data terminals
- Instrumentation
- Electronic test and measurement equipment

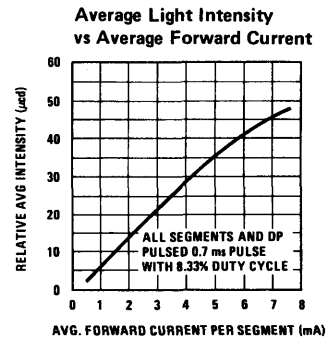
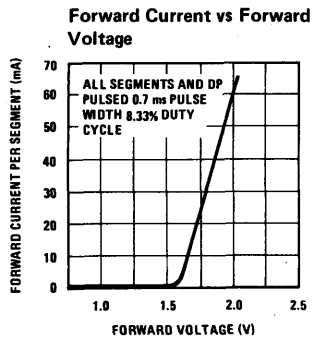
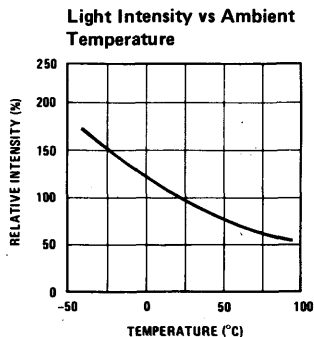
### Absolute Ratings

Average Current per Segment	0.25 mA min, 6 mA max
Peak Current per Segment	3 mA min, 70 mA max 3.0V max
Reverse Voltage	1.0 ms max
Digit Current Pulse Width	-20°C to +70°C
Operating and Storage Temperatures	98% max
Relative Humidity at 35°C	230°C max
Terminal Temperature (Soldering, 5 seconds)	

### Electrical and Optical Characteristics $T_A = 25^\circ\text{C}$ Room Temperature

PARAMETER	CONDITIONS	MIN	TYP	MAX	UNITS
Segment Light Intensity (Peak)	5.0 mA/Segment Peak 1/12 Duty Cycle	0.10	0.35		mcd
Segment Forward Voltage	5.0 mA/Segment DC		1.8	2.0	V
Reverse Voltage	100 $\mu\text{A}$ /Segment	3.0	8.0		V
Intensity Matching			$\pm 33$		%
Peak Wavelength			660		nm
Spectral Width, Half-Intensity			40		nm
Viewing Angle, Off Axis, Horizontal			20		Degrees
Viewing Angle, Off Axis, Vertical			20		Degrees

### Typical Performance Characteristics (25°C)





## Custom Options NSA71XX Series

Custom options are available as follows:

- Number of digits, 9–12
- Number of decimal points, maximum of 12
- Minus signs can be substituted in place of any digit. Address line will be segment G
- A decimal point can be substituted for any digit and placed in any segment position. (Will be electrically connected to that segment address line)
- For all other variations it is recommended the factory be contacted

## Recommended Display Array Processing

The NSA7120 array is constructed on a standard printed circuit board substrate and covered with a plastic lens.

The edge connectors tab will stand a temperature of 230°C for 5 seconds.

The display lens area must not be elevated in temperature above 70°C. To do so will result in permanent damage to the display.

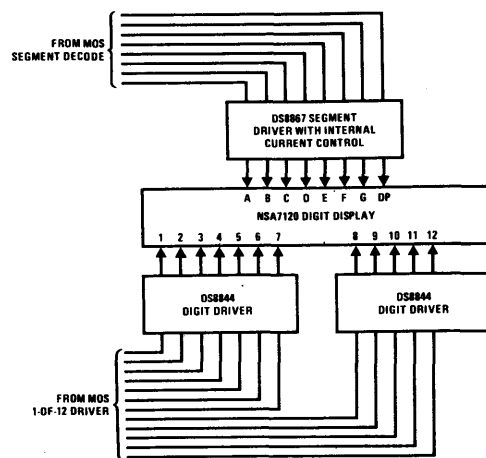
It is recommended that the back of the display be masked off with low tac masking tape during flux and clean operations, to prevent condensation of flux or cleaner on the underside of the lens.

It is also recommended that only localized cleaning with a cotton swab on external surfaces be performed after soldering.

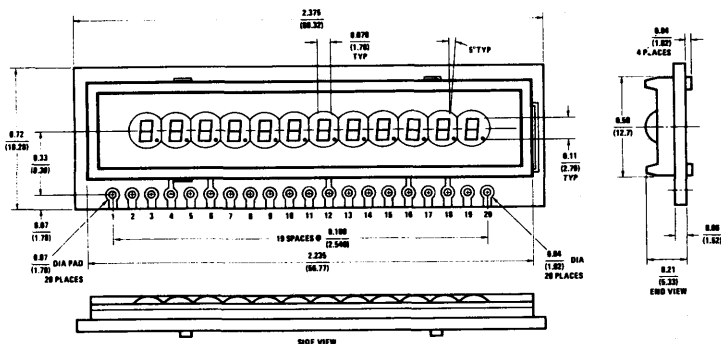
Only rosin core solder, solid core solder and low temperature deactivating fluxes are recommended. Recommended post solder cleaning solvents are Freon TF, Isopropanol, Methanol or Ethanol. These solvents are recommended only at room temperature and for short time periods.

The use of other solvents or elevated temperature use of the recommended solvents may cause permanent damage to the lens or the display.

## Typical Drive Circuit



## Physical Dimensions and Pin Connections inches (millimeters)



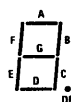
PIN NO.	ELECTRICAL CONNECTION
1	Digit 1 Cathode
2	Digit 2 Cathode
3	Digit 3 Cathode
4	Segment C Anode
5	Digit 4 Cathode
6	Segment DP Anode
7	Digit 5 Cathode
8	Segment A Anode
9	Digit 6 Cathode
10	Segment E Anode
11	Digit 7 Cathode
12	Segment D Anode
13	Digit 8 Cathode
14	Segment G Anode
15	Digit 9 Cathode
16	Segment B Anode
17	Digit 10 Cathode
18	Segment F Anode
19	Digit 11 Cathode
20	Digit 12 Cathode

Note 1: Material: PC-75 circuit board or approved equivalent.

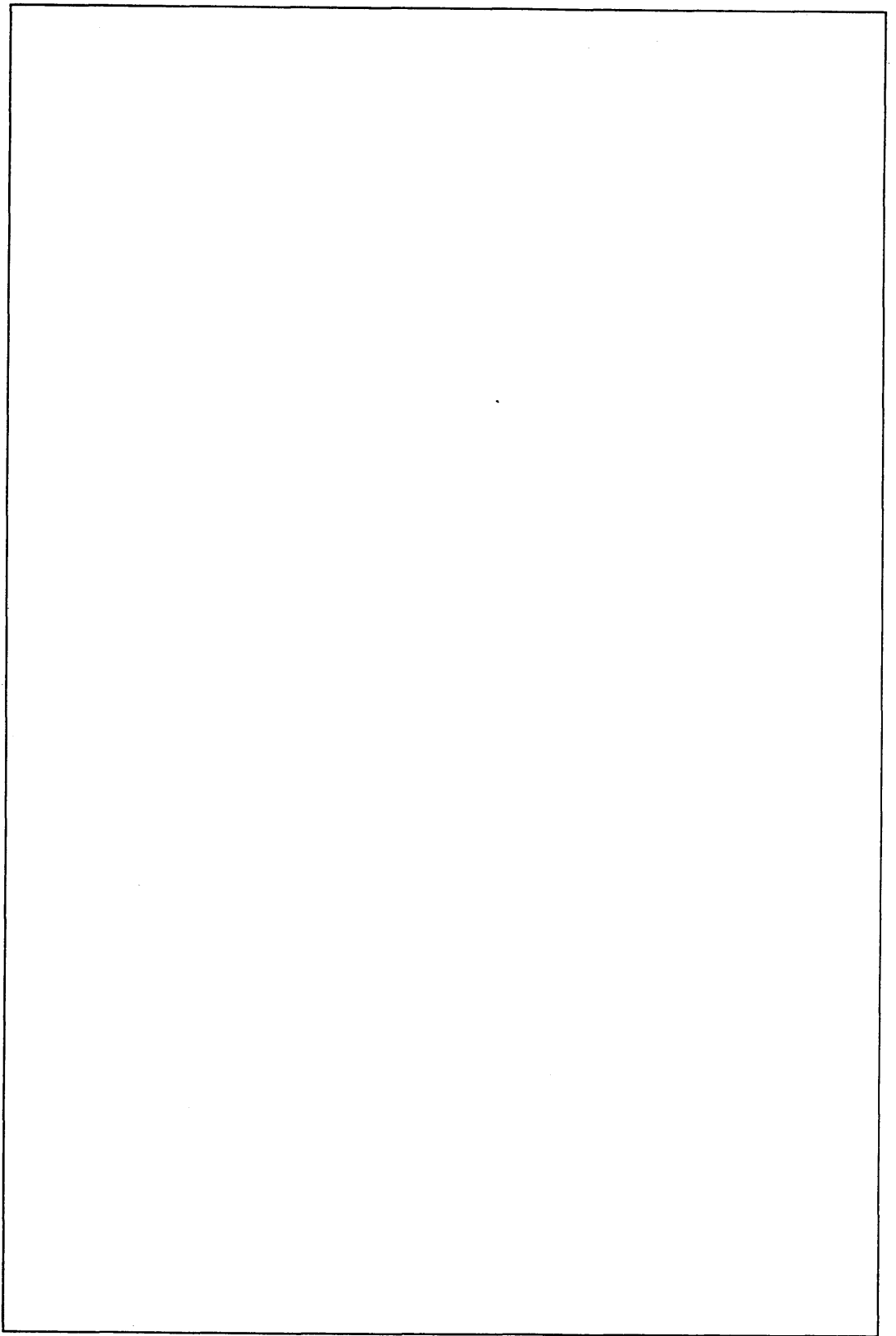
Note 2: 12 digits on 0.175/(4.445) centers.

Note 3: All tolerance  $\pm 0.015$  (0.381).

### Segment Designation



Order Number NSA7120 for 12-Digit Unit  
Special Numbers are Assigned for Custom Units NSA71XX





## Multidigit LED Numeric Displays

### Introduction

National Semiconductor offers a wide range of red multidigit GaAsP LED reflective displays, representing the latest design advances in 0.3", 0.5" and 0.7" formats. The series provides the designer with an effective, easy to implement answer to the need for an inexpensive large numeric display.

### Features

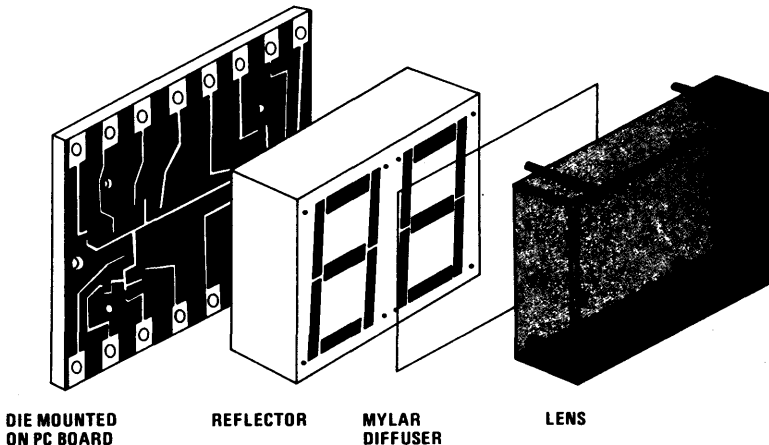
- The end stackability of the 2-digit and 4-digit displays allows for a wide range of options for applications requiring additional digits.
- Prematched light intensity of digits within each display is guaranteed to insure uniform brightness.
- PCB mounting decreases overall cost per digit and allows for easier board mounting.
- The optical design of this series affords an easy-to-read display with a wide viewing angle and excellent ON-OFF contrast.

### Applications

- Industrial controls
- Data terminals
- Test equipment
- Point of sale
- Mini-computer readout
- Home consumer application

### Custom Displays

The products listed in this data book are standard inventory items designed to meet the majority of your needs for an inexpensive numeric display. The modular construction of these displays offers a great deal of flexibility in display format and drive considerations through modification of the PC board design. If you have a volume application not met by one of the standard product configurations listed, contact the National Sales Office nearest you for an LED display custom designed to your needs.



DIE MOUNTED  
ON PC BOARD

REFLECTOR

MYLAR  
DIFFUSER

LENS

# Multidigit LED Numeric Display Selection Guide

## MULTIPURPOSE DISPLAYS

Device Type	Digit Size	Format	Drive	Light Intensity (Typ)	Forward Voltage (Typ)
NSN334 NSN373 NSN374 NSN381 NSN382	0.3"	+1.8. 8.8 No D'P 8.8 No D'P 8.8 8.8	Common Anode—Direct Common Cathode—Direct Common Anode—Direct Common Cathode—Multiplexed Common Anode—Multiplexed	1.6 mcd	1.7V@10 mA peak
NSN534 NSN581 NSN582 NSN583 NSN584	0.5"	+1.8. 8.8 8.8 8.8 8.8	Common Anode—Direct Common Cathode—Multiplexed Common Anode—Multiplexed Common Cathode—Direct Common Anode—Direct	1.6 mcd	1.7V@10 mA peak
NSN734 NSN781 NSN782 NSN783 NSN784	0.7"	+1.8. 8.8 8.8 8.8 8.8	Common Anode—Direct Common Cathode—Multiplexed Common Anode—Multiplexed Common Cathode—Direct Common Anode—Direct	1.6 mcd	1.7V@10 mA peak
NSB3382 NSB3881 NSB3882	0.3"	+1.8.8.8. 8.8.8.8. 8.8.8.8.	Common Anode—Multiplexed Common Cathode—Multiplexed Common Anode—Multiplexed	1.6 mcd	1.7V@10 mA peak
NSB5382 NSB5388 NSB5415 NSB5881 NSB5882	0.5"	+1.8.8.8. +1.8.8.8. +8.8.8.8. 8.8.8.8. 8.8.8.8.	Common Anode—Multiplexed Common Cathode—Multiplexed Common Cathode—Multiplexed Common Cathode—Multiplexed Common Anode—Multiplexed	1.6 mcd	1.7V@10 mA peak
NSB7382 NSB7881 NSB7882	0.7"	+1.8.8.8. 8.8.8.8. 8.8.8.8.	Common Anode—Multiplexed Common Cathode—Multiplexed Common Anode—Multiplexed	1.6 mcd	1.7V@10 mA peak
NSB5917  NSB5918 NSB5921 NSB5922 NSB5931	0.5"	+1.8.8.8.8.  +8.8.8.8. 8.8.8.8. 8.8.8.8. 8.8.8.8.	Common Anode— + 1 Direct, 4 Digits Multiplexed Common Cathode—Multiplexed Common Cathode—Multiplexed Common Anode—Multiplexed Common Cathode—Multiplexed	1.6 mcd	1.7V@10 mA peak

## CLOCK DISPLAYS

Part #	Feature/Function
NSB7400	12-hour format with single piece reflector; with PM indicator; with red plastic lens.
NSB7401	24-hour format with single piece reflector; without PM indicator; with red plastic lens.
NSB7402	12-hour format with single piece reflector; with PM indicator; with red mylar tape (no lens).
NSB7403	12-hour format with single piece reflector; with PM indicator; with clear mylar tape (no lens).
NSB7404	24-hour format with single piece reflector; without PM indicator; with red mylar tape (no lens).
NSB7405	24-hour format with single piece reflector; without PM indicator; with clear mylar tape (no lens).

# Multidigit LED Numeric Display Cross Reference

## PC BOARD MOUNTED DISPLAYS

Part Number	Description	NSC Device	Notes
<b>Litronix</b>			
DL3531	0.5" Red 3½ Digit, Common Anode, Mux	NSB5382	B, C, D
DL4530	0.5" Red 4 Digit, Common Anode, Mux	NSB5882	B, C, D
DL6500	0.5" Red 6 Digit, Common Cathode, Mux	NSB5931	A
<b>Texas Instruments</b>			
TIL361	0.5" Red Dual Digit, Common Cathode, Mux	NSN581	B, C, D

**Notes:** A—Direct replacement  
 B—Difference in PC board dimensions  
 C—Difference in pinout  
 D—Difference in pin location

## DIGITS IN MOLDED DIPs\*

Part Number	Description	NSC Device
<b>Hewlett-Packard</b>		
5082-7731	0.3" Red Single Digit, Common Anode	NSN334, NSN374, NSN382
5082-7740	0.3" Red Single Digit, Common Cathode	NSN373, NSN381
<b>Monsanto</b>		
MAN71A	0.3" Red Single Digit, Common Anode	NSN334, NSN374, NSN382
MAN74A	0.3" Red Single Digit, Common Cathode	NSN373 or NSN381
<b>Fairchild</b>		
FND500	0.5" Red Single Digit, Common Cathode	NSN581 or NSN583
FND507	0.5" Red Single Digit, Common Anode	NSN534, NSN582, NSN584
<b>Litronix</b>		
DL704	0.3" Red Single Digit, Common Cathode	NSN373 or NSN381
DL707R	0.3" Red Single Digit, Common Anode	NSN334, NSN374, NSN382
DL721	0.5" Red 1-½ Digit, Common Anode	NSN534
DL727	0.5" Red Dual Digit, Common Anode	NSN582 or NSN584
DL728	0.5" Red Dual Digit, Common Cathode	NSN581 or NSN583
<b>Texas Instruments</b>		
TIL313	0.3" Red Single Digit, Common Cathode	NSN373 or NSN381
TIL321	0.5" Red Single Digit, Common Anode	NSN534, NSN582, NSN584
TIL322	0.5" Red Single Digit, Common Cathode	NSN581 or NSN583

\* National's PC board mounted LED displays represent a new concept in display packaging and do not directly replace the older, more expensive single digits still being offered by the competition. Competitive single digits must be wired by the user for either multiplex or direct drive while the NSC units are "pre-wired" on the PC board. Another variable is the number of digits per package. The National NSN series is 2 digits per package and the NSB series is 4, 5 or 6 digits per package.



## NSB5388 3 1/2-Digit 0.5 Inch (12.70 mm) LED Display

### General Description

The NSB5388 is a 3 1/2-digit, 0.5 inch (12.70 mm) high GaAsP LED display. Basically a common cathode multiplexed display, the NSB5388 features separate access to the  $\pm$  sign and decimal points and is directly compatible with the ADD3500, ADD3501 DVM circuit. Electrical connection is by PCB type terminals on the edge of the display.

The optical design of this unit creates a distinct, easy to read display with a wide viewing angle, excellent ON/OFF contrast and segment uniformity. The NSB5388 provides the designer with an effective, easy to implement answer to the need for an inexpensive large numeric display.

### Recommended Display Processing

The multidigit series display is constructed on a standard printed circuit board substrate and covered with a plastic lens. The edge connector tab will stand 230°C for 5 seconds. Permanent damage to the display will result if lens temperature exceeds 70°C. Since the display is not hermetic, immersion of the entire package during flux and clean operation may cause condensation of flux or cleaner on the underside of the lens. Only the edge connectors should be immersed.

Rosin core solder, solid core solder, and low activity organic fluxes are recommended. Freon TF, Isopropanol, Methanol or Ethanol solvents are recommended only at room temperature and for short periods. The use of other solvents or elevated temperature use of the recommended solvents may cause permanent damage to the lens or display.

### Applications

- Digital instrumentation
  - Power supply readouts
  - Multimeters
  - Panel meters

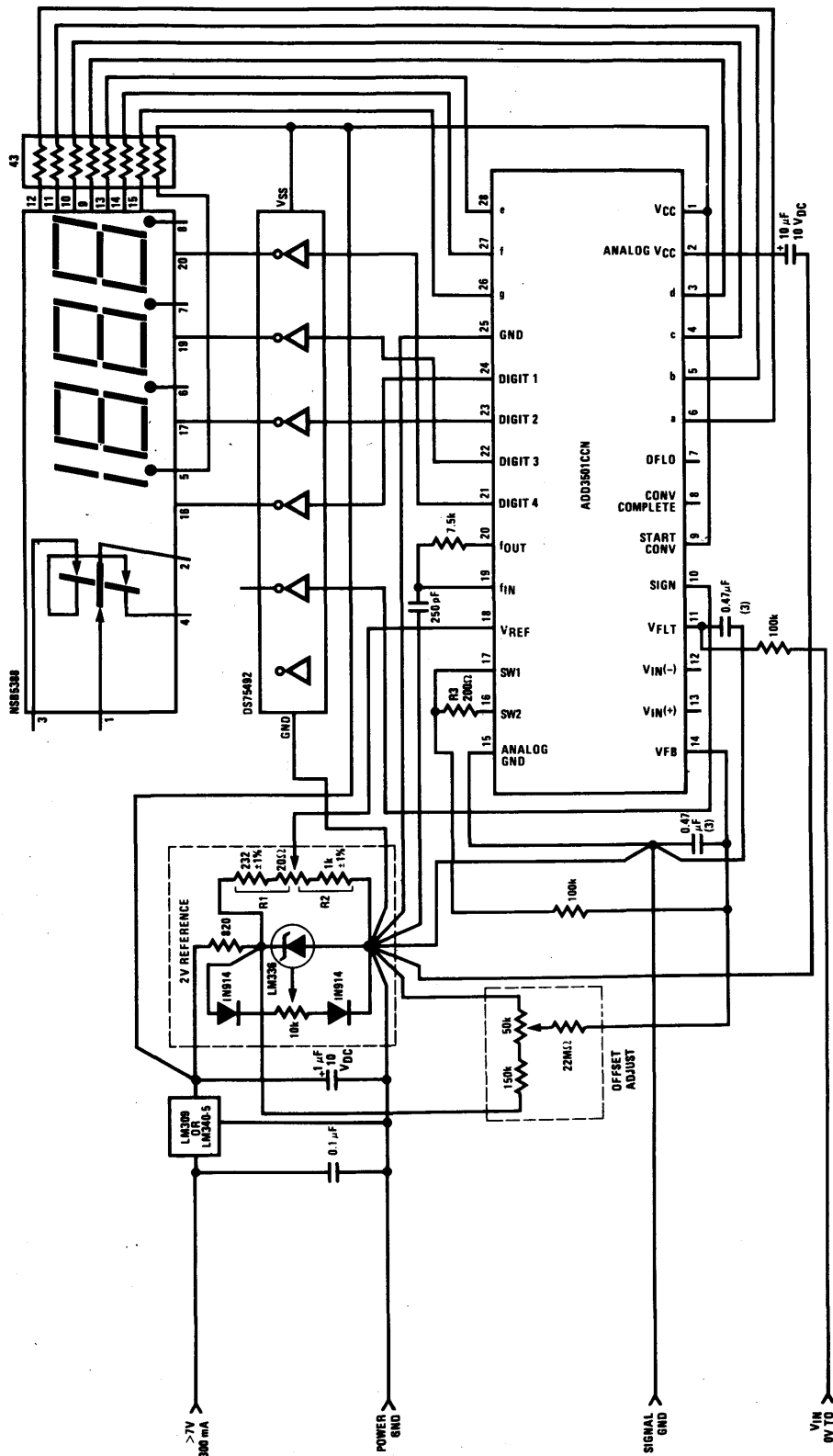
### Absolute Ratings

Average Current per Segment	20 mA max
Peak Current per Segment	75 mA max
Reverse Voltage per Segment	3.0V max
Operating and Storage Temperature	-20°C to +70°C
Relative Humidity at 35°C	98%
Lead Temperature (Soldering, 5 seconds)	230°C

### Electrical and Optical Characteristics $T_A = 25^\circ\text{C}$

PARAMETER	CONDITIONS	MIN	TYP	MAX	UNITS
Segment Light Intensity (Peak)	10 mA/Seg. Peak	0.10	0.20		mcd
Digit and D.P. Light Intensity (Peak)	10 mA/Seg. Peak	0.80	1.6		mcd
Segment Forward Voltage	10 mA/Seg. Peak		1.7	2.0	V
Segment Reverse Voltage	100 $\mu$ A/Seg.	3.0	8.0		V
Peak Wavelength			660		nm
Spectral Width, Half-Intensity			40		nm
Viewing Angle, Off Axis			60		degrees
Intensity Matching	10 mA/Seg. Avg.		$\pm$ 33		%

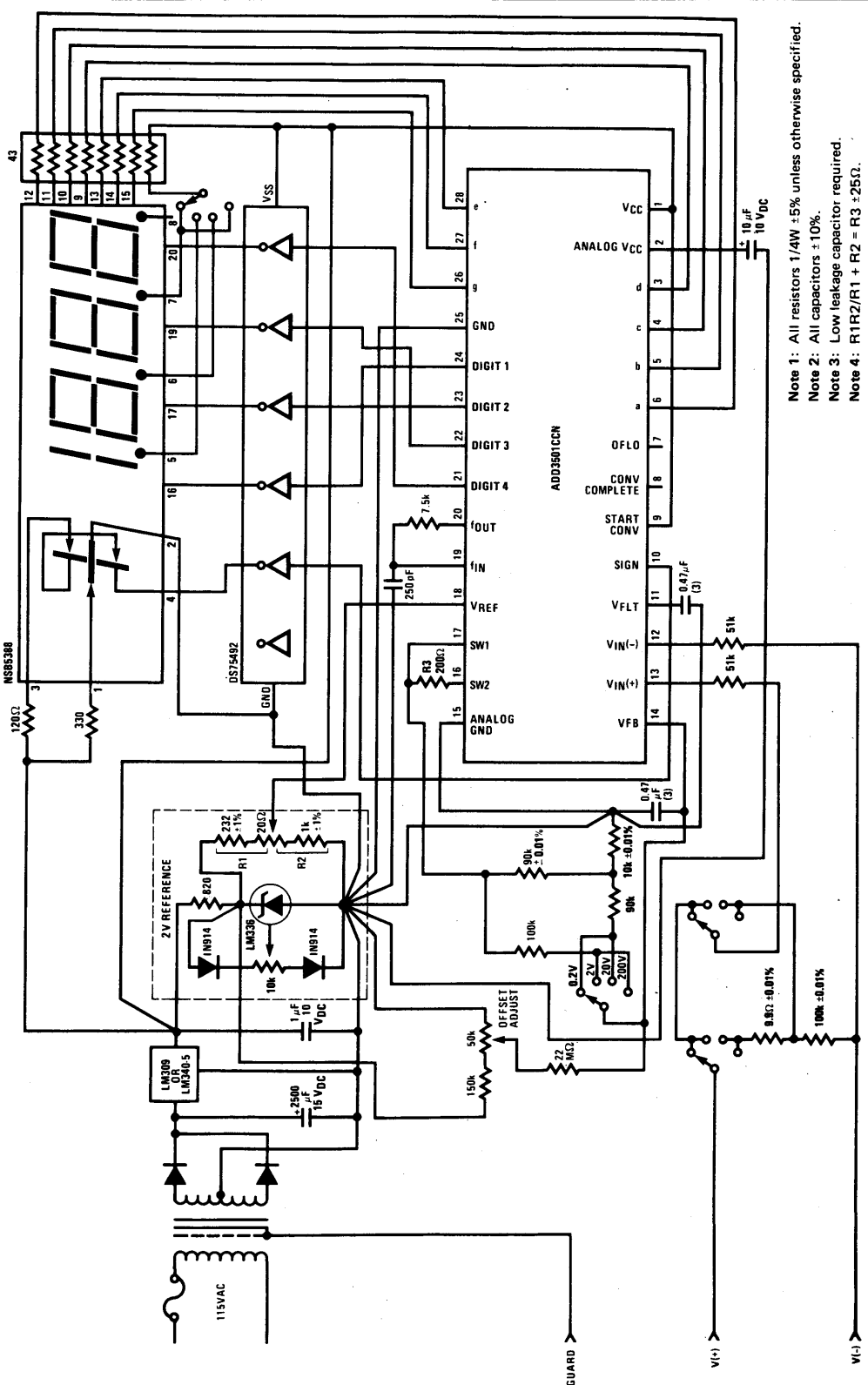
# Typical Applications



- Note 1: All resistors 1/4W ±5% unless otherwise specified.
- Note 2: All capacitors ±10%.
- Note 3: Low leakage capacitor required.
- Note 4:  $R1R2/R1 + R2 = R3 \pm 25\Omega$ .

FIGURE 1.3 1/2-Digit DPM, +1.999V Full-Scale

Typical Applications (Continued)



- Note 1: All resistors 1/4W ±5% unless otherwise specified.
- Note 2: All capacitors ± 10%.
- Note 3: Low leakage capacitor required.
- Note 4: R1R2/R1 + R2 = R3 ±25Ω.

FIGURE 2. 3 1/2-Digit DVM, 4-Decade, ±0.2V, ±2V, ±20V and ±200V Full-Scale

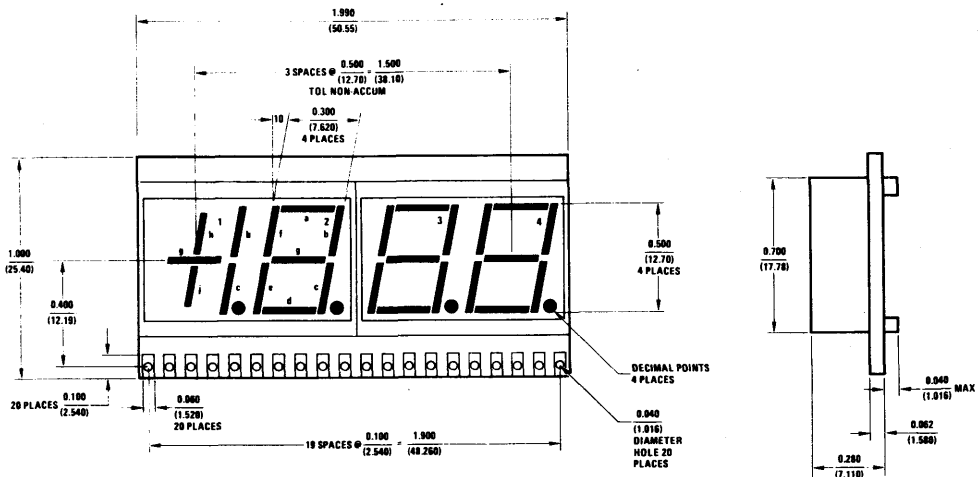


Pin Connections

PIN NO.	ELECTRICAL CONNECTION
1	Digit No. 1 Segment G Anode
2	Digit No. 1 Segment G Cathode
3	Digit No. 1 Segment H Anode *
4	Digit No. 1 Segment J Cathode *
5	Digit No. 1 Segment DP Anode
6	Digit No. 2 Segment DP Anode
7	Digit No. 3 Segment DP Anode
8	Digit No. 4 Segment DP Anode
9	Segment D Anode
10	Segment C Anode
11	Segment B Anode
12	Segment A Anode
13	Segment E Anode
14	Segment F Anode
15	Segment G Anode
16	Digit No. 1 Cathode
17	Digit No. 2 Cathode
18	NC
19	Digit No. 3 Cathode
20	Digit No. 4 Cathode

\*Segments H and J internally connected in series

Physical Dimensions inches (millimeters)



Note 1: Material: super-punch circuit board or approved equivalent 0.062 thick.

Note 2: All tolerances are 0.015 (0.38).



## NSB5415 4 1/2-Digit 0.5 Inch (12.70 mm) LED Display

### General Description

The NSB5415 is a 4 1/2-digit, 0.5 inch (12.70 mm) high GaAsP LED display. Basically a common cathode multiplexed display, the NSB5415 features separate access to the  $\pm$  sign and decimal points and is directly compatible with the ADB4510, ADB4511 DVM circuit. Electrical connection is by PCB type terminals on the edge of the display.

The optical design of this unit creates a distinct, easy to read display with a wide viewing angle, excellent ON/OFF contrast and segment uniformity. The NSB5415 provides the designer with an effective, easy to implement answer to the need for an inexpensive large numeric display.

### Recommended Display Processing

The multidigit series display is constructed on a standard printed circuit board substrate and covered with a plastic lens. The edge connector tab will stand 230°C for 5 seconds. Permanent damage to the display will result if lens temperature exceeds 70°C. Since the display is not hermetic, immersion of the entire package during flux and clean operation may cause condensation of flux or cleaner on the underside of the lens. Only the edge connectors should be immersed.

Rosin core solder, solid core solder, and low activity organic fluxes are recommended. Freon TF, Isopropanol, Methanol or Ethanol solvents are recommended only at room temperature and for short periods. The use of other solvents or elevated temperature use of the recommended solvents may cause permanent damage to the lens or display.

### Applications

- Digital instrumentation
  - Power supply readouts
  - Multimeters
  - Panel meters

### Absolute Ratings

Average Current per Segment	20 mA max
Peak Current per Segment (100 $\mu$ sec pulse)	150 mA max
Reverse Voltage per Segment	3.0V max
Operating and Storage Temperature	-20°C to +70°C
Relative Humidity at 35°C	98%
Lead Temperature (Soldering, 5 seconds)	230°C

### Electrical and Optical Characteristics $T_A = 25^\circ\text{C}$

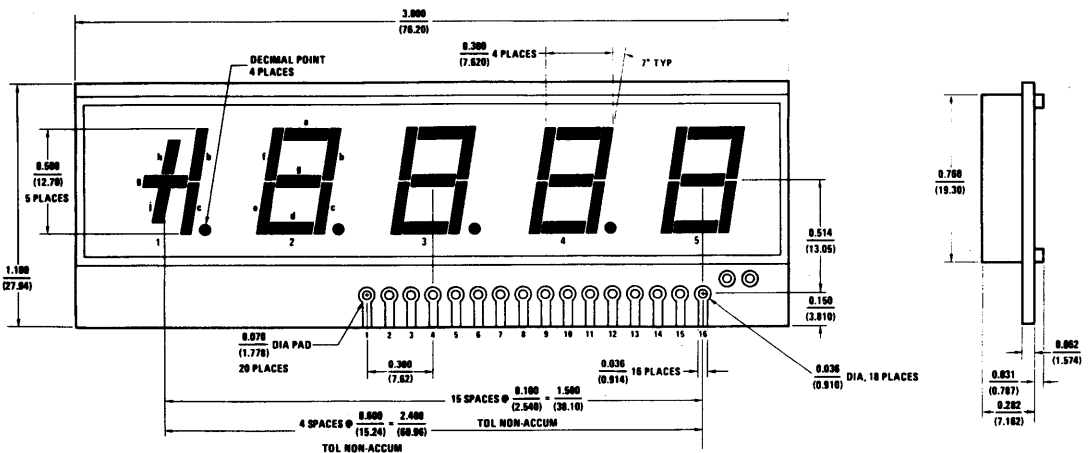
PARAMETER	CONDITIONS	MIN	TYP	MAX	UNITS
Segment Light Intensity (Peak)	10 mA/Seg. Peak	0.10	0.20		mcd
Digit and D.P. Light Intensity (Peak)	10 mA/Seg. Peak	0.80	1.6		mcd
Segment Forward Voltage	10 mA/Seg. Peak		1.7	2.0	V
Segment Reverse Voltage	100 $\mu$ A/Seg.	3.0	8.0		V
Peak Wavelength			660		nm
Spectral Width, Half-Intensity			40		nm
Viewing Angle, Off Axis			60		degrees
Intensity Matching	10 mA/Seg. Avg.		$\pm 33$		%



Pin Connections

PIN NO.	ELECTRICAL CONNECTION
1	Anode G
2	Anode F (Digit 1 Only, H)
3	Anode E (Digit 1 Only, J)
4	Anode D
5	Anode A
6	Anode C
7	Anode B
8	NC
9	Anode DP
10	NC
11	NC
12	Cathode 1
13	Cathode 2
14	Cathode 4
15	Cathode 5
16	Cathode 3

Physical Dimensions inches (millimeters)



**Note 1:** Material: G-10 circuit board natural or approved equivalent, unless otherwise specified.

**Note 2:** 5 digits on 0.600 (15.24) centers, unless otherwise specified.

**Note 3:** Tolerances: ±0.015 (0.38), unless otherwise specified.

## NSB5917, NSB5921, NSB5922 0.5 Inch (12.70 mm) 5 Digit Numeric Displays

### General Description

The 5900 series of GaAsP LED reflective displays from National Semiconductor represent the latest in design advances to provide you with an effective, easy to implement answer to the need for an inexpensive large numeric display.

Versatility is offered with both common anode (NSB5922) and common cathode (NSB5921) multiplexed versions for 5 full digits and an option of direct drive overflow/polarity indication with 4 digits in a common anode multiplexed format (NSB5917). Electrical connection is by PCB type terminals on the edges of the display.

The optical design of this display series creates a distinct, easy to read display with wide viewing angle, excellent "ON-OFF" contrast, and segment uniformity.

### Applications

- Test and measurement equipment
- Consumer products
- Industrial controls
- Desk top calculators
- Digital instruments

### Absolute Ratings

Average Current Per Segment	20 mA max
Peak Current Per Segment	75 mA max
Reverse Voltage Per Segment	3V min
Operating and Storage	
Temperature	-20°C to +70°C
Relative Humidity at 35°C	98%
Terminal Temperature (Soldering, 5 seconds)	230°C

### Recommended Display Processing

The multi-digit series display is constructed on a standard printed circuit board substrate and covered with a plastic lens. The edge connector tab will stand a temperature of 230°C for 5 seconds. The display lens area must not be elevated in temperature above 70°C. To do so will result in permanent damage to the display. Since the display is not hermetic, immersion of the entire package during flux and clean operations may cause condensation of flux or cleaner on the underside of the lens. It is recommended that only the edge connectors be immersed. Only rosin core solder, solid core solder, and low activity organic fluxes are recommended. Cleaning solvents are Freon TF, Isopropanol, Methanol, or Ethanol. These solvents are recommended only at room temperature and for short time periods. The use of other solvents or elevated temperature use of the recommended solvents may cause permanent damage to the lens or display.

### Electrical and Optical Characteristics (25°C)

PARAMETER	CONDITIONS	MIN	TYP	MAX	UNITS
Segment Light Intensity (Peak)	10 mA/Segment Average	0.10	0.20		mcd
Digit and D.P. Light Intensity (Peak)	10 mA/Segment Average	0.80	1.6		mcd
Segment Forward Voltage	10 mA/Segment Peak		1.7	2.0	V
Segment Reverse Voltage	100 $\mu$ A/Segment	3.0	8.0		V
Peak Wavelength			660		nm
Spectral Width, Half-Intensity			40		nm
Viewing Angle, Off Axis			60		degrees
Intensity Matching	10 mA/Segment Average		$\pm$ 33		%

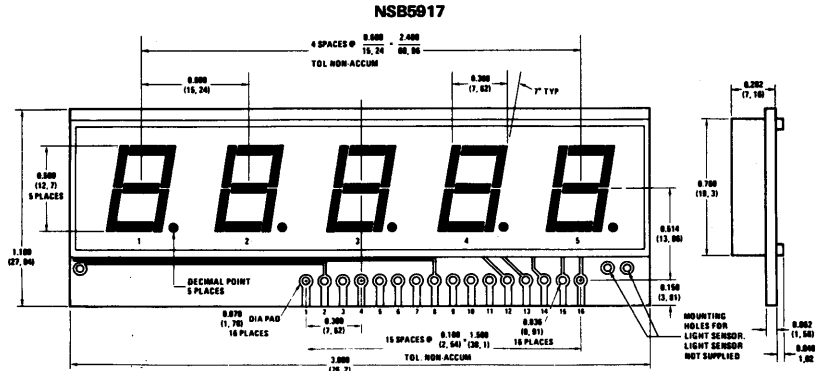
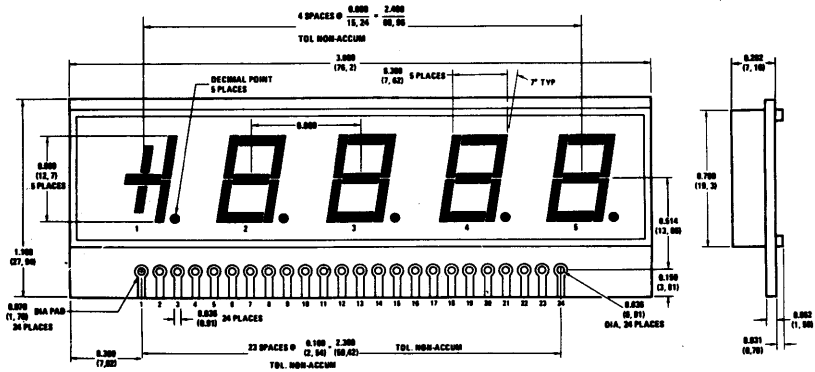
## Pin Connections

NSB5917	
PIN NO.	ELECTRICAL CONNECTION
1	Digit 1 Anode H
2	Digit 1 Cathode H
3	Digit 1 Anode J
4	Digit 1 Cathode J
5	Digit 1 Cathode G
6	Digit 1 Anode G
7	Digit 1 Anode D.P.
8	Digit 1 Cathode D.P.
9	Digit 1 Cathode C
10	Digit 1 Anode C
11	Digit 1 Cathode B
12	Digit 1 Anode B
13	Digit 2 Anode
14	Digit 3 Anode
15	Cathode G
16	Cathode F
17	Cathode E
18	Cathode D
19	Digit 4 Anode
20	Digit 5 Anode
21	Cathode D.P.
22	Cathode C
23	Cathode B
24	Cathode A

NSB5921	
PIN NO.	ELECTRICAL CONNECTION
1	Anode G
2	Anode F
3	Anode E
4	Anode D
5	Anode A
6	Anode C
7	Anode B
8	NC
9	Anode D.P.
10	Light Sensor
11	Light Sensor
12	Cathode 1
13	Cathode 2
14	Cathode 4
15	Cathode 5
16	Cathode 3

NSB5922	
PIN NO.	ELECTRICAL CONNECTION
1	Cathode G
2	Cathode F
3	Cathode E
4	Cathode D
5	Cathode A
6	Cathode C
7	Cathode B
8	NC
9	Cathode D.P.
10	Light Sensor
11	Light Sensor
12	Anode 1
13	Anode 2
14	Anode 4
15	Anode 5
16	Anode 3

## Physical Dimensions and Display Capability Outline inches (millimeters)



## NSB5918 3 3/4-Digit 0.5 Inch (12.70 mm) LED Display

### General Description

The NSB5918 is a 3 3/4-digit, 0.5 inch (12.70 mm) high GaAsP LED display. Basically a common cathode multiplexed display, the NSB5918 features separate access to the  $\pm$  sign and decimal points and is directly compatible with the ADD3701 DVM circuit. Electrical connection is by PCB type terminals on the edge of the display. The 3 3/4-digit is distinguished from the 3 1/2 and 4 1/2-digit designs by the fact that the overflow sign is followed by 4 full 7-segment digits.

The optical design of this unit creates a distinct, easy to read display with a wide viewing angle, excellent ON/OFF contrast and segment uniformity. The NSB5918 provides the designer with an effective, easy to implement answer to the need for an inexpensive large numeric display.

### Recommended Display Processing

The multidigit series display is constructed on a standard printed circuit board substrate and covered with a plastic lens. The edge connector tab will stand 230°C for 5 seconds. Permanent damage to the display will result if lens temperature exceeds 70°C. Since the display is not hermetic, immersion of the entire package during flux and clean operation may cause condensation

of flux or cleaner on the underside of the lens. Only the edge connectors should be immersed.

Rosin core solder, solid core solder, and low activity organic fluxes are recommended. Freon TF, Isopropanol, Methanol or Ethanol solvents are recommended only at room temperature and for short periods. The use of other solvents or elevated temperature use of the recommended solvents may cause permanent damage to the lens or display.

### Applications

- Digital instrumentation
  - Power supply readouts
  - Multimeters
  - Panel meters

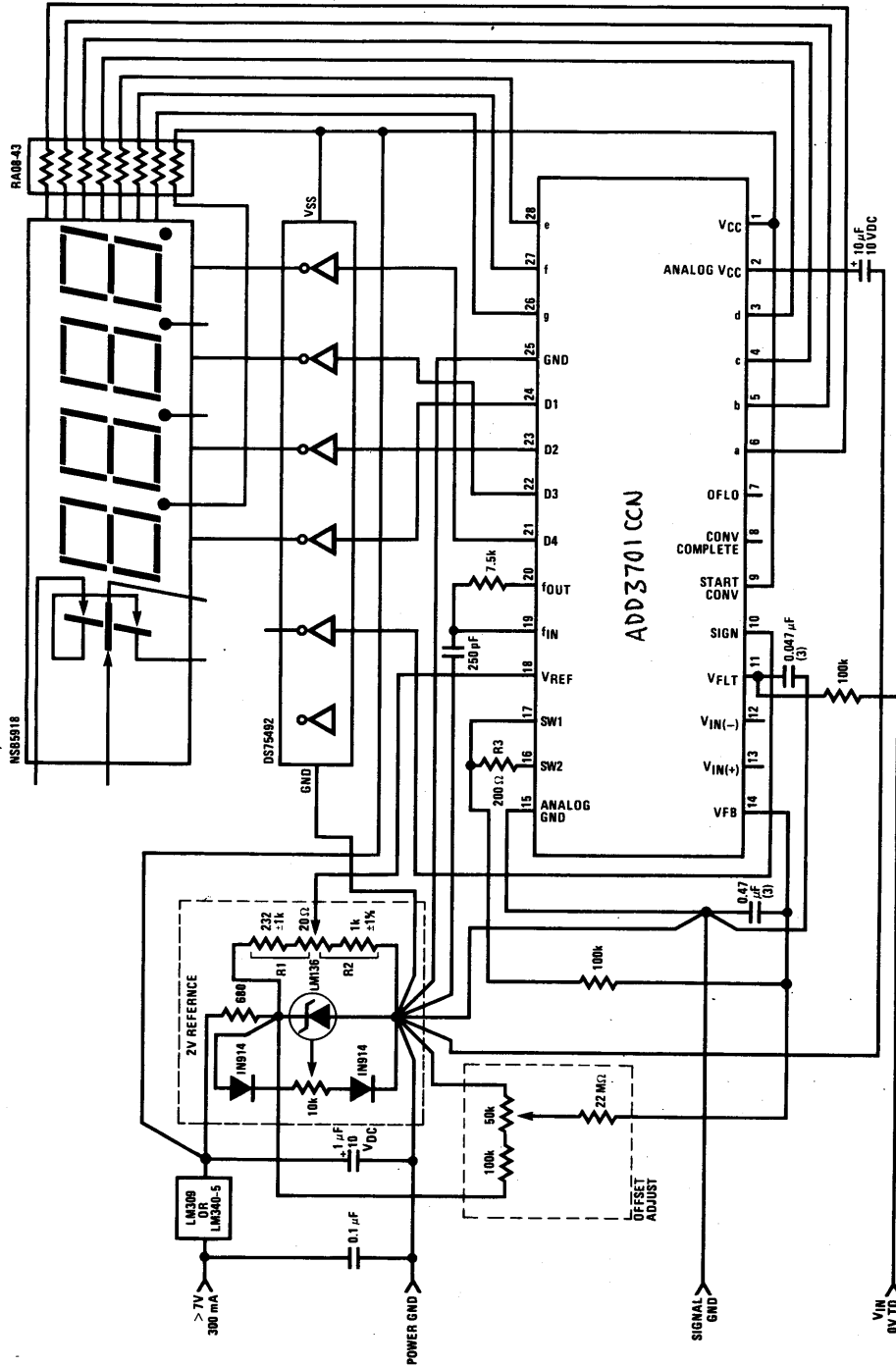
### Absolute Ratings

Average Current per Segment	20 mA max
Peak Current per Segment (100 $\mu$ sec pulse)	150 mA max
Reverse Voltage per Segment	3.0V max
Operating and Storage Temperature	-20°C to +70°C
Relative Humidity at 35°C	98%
Lead Temperature (Soldering, 5 seconds)	230°C

### Electrical and Optical Characteristics $T_A = 25^\circ\text{C}$

PARAMETER	CONDITIONS	MIN	TYP	MAX	UNITS
Segment Light Intensity	10 mA/Seg. Avg.	0.10	0.20		mcd
Digit and D.P. Light Intensity	10 mA/Seg. Avg.	0.80	1.6		mcd
Segment Forward Voltage	10 mA/Seg.		1.7	2.0	V
Segment Reverse Voltage	100 $\mu$ A/Seg.	3.0	8.0		V
Peak Wavelength			660		nm
Spectral Width, Half-Intensity			40		nm
Viewing Angle, Off Axis			60		degrees
Intensity Matching	10 mA/Seg. Avg.		$\pm 33$		%

Typical Applications

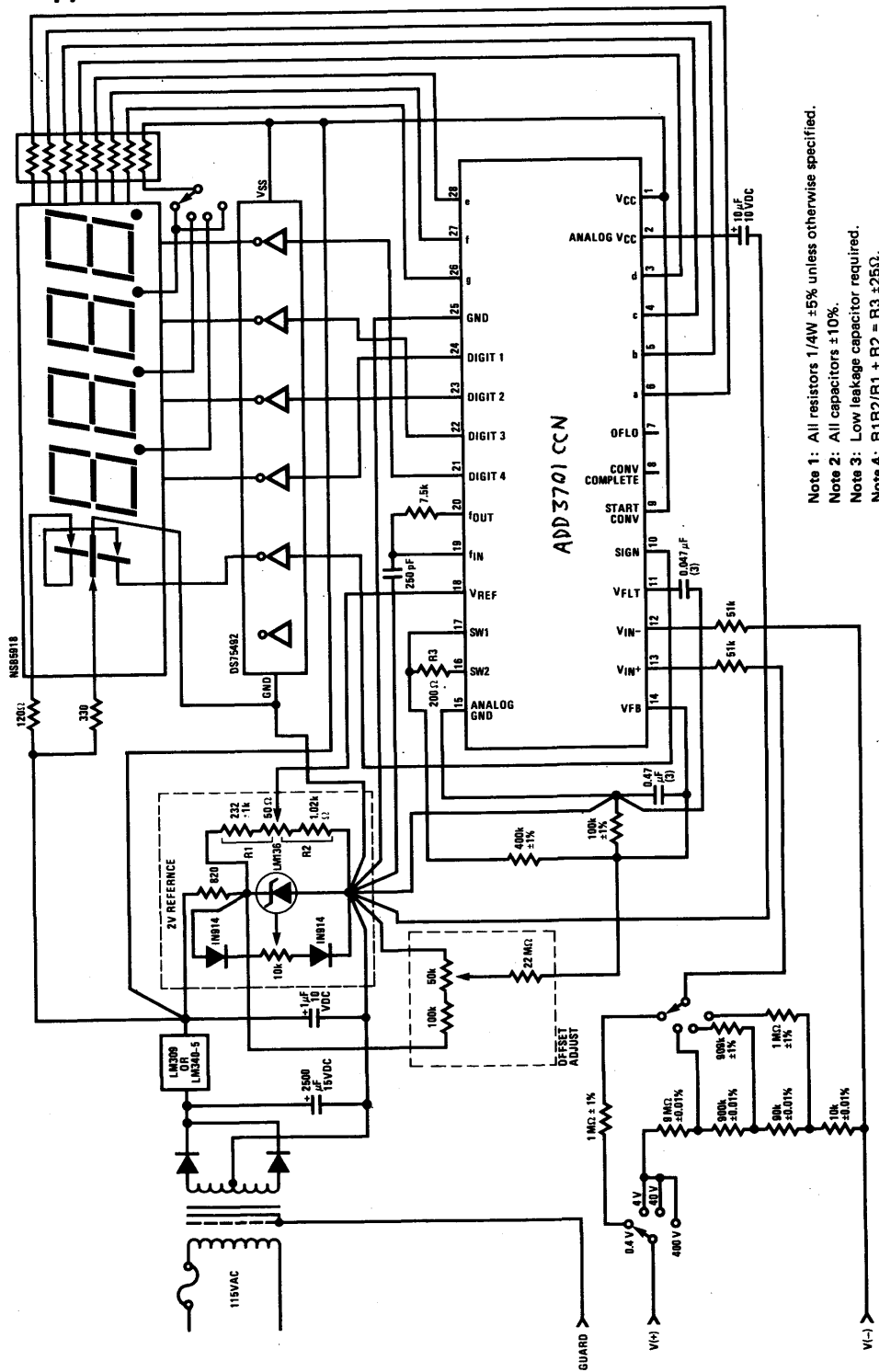


- Note 1: All resistors 1/4W ±5% unless otherwise specified.
- Note 2: All capacitors ±10%.
- Note 3: Low leakage capacitor required.
- Note 4:  $R1R2/R1 + R2 = R3 ± 25\Omega$ .

FIGURE 1. 3 3/4-Digit DVM, +3.999 Count Full-Scale



Typical Applications (Continued)



- Note 1: All resistors 1/4W ±5% unless otherwise specified.
- Note 2: All capacitors ±10%.
- Note 3: Low leakage capacitor required.
- Note 4:  $R1/R2/R1 + R2 = R3 \pm 25\Omega$ .

FIGURE 2. 3 3/4-Digit DVM, 4-Decade, ±0.4V, ±4V, ±40V and ±400V Full-Scale

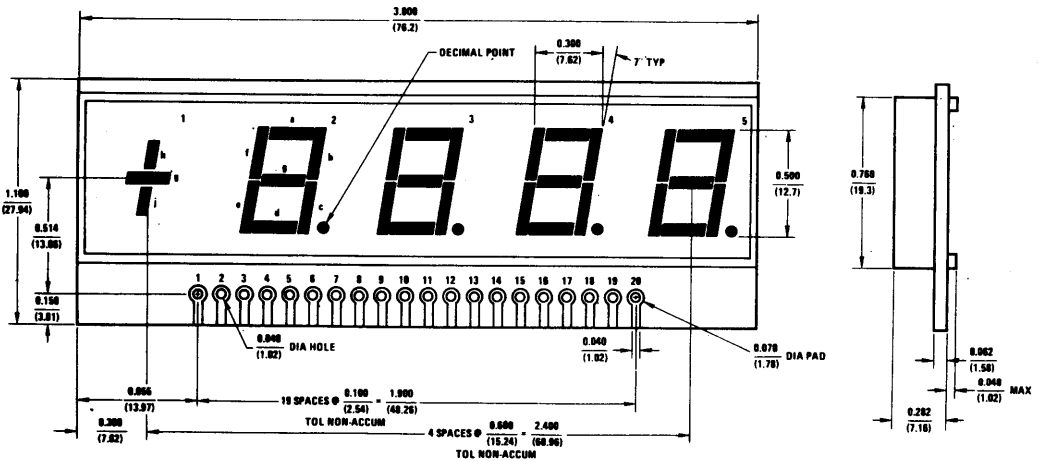
NSB5918

Pin Connections

PIN NO.	ELECTRICAL CONNECTION
1	Digit No. 1 Segment G Anode
2	Digit No. 1 Segment G Cathode
3	Digit No. 1 Segment H Anode*
4	Digit No. 1 Segment J Cathode*
5	Digit No. 2 Segment DP Anode
6	Digit No. 3 Segment DP Anode
7	Digit No. 4 Segment DP Anode
8	Digit No. 5 Segment DP Anode
9	Segment D Anode
10	Segment C Anode
11	Segment B Anode
12	Segment A Anode
13	Segment E Anode
14	Segment F Anode
15	Segment G Anode
16	Digit No. 2 Cathode
17	Digit No. 3 Cathode
18	NC
19	Digit No. 4 Cathode
20	Digit No. 5 Cathode

\*Segments H and J internally connected in series

Physical Dimensions inches (millimeters)



Note 1: Material: super-punch circuit board or approved equivalent 0.062/(1.57) thick.

Note 2: All tolerances are 0.015 (0.38).

## NSB5931 0.5 Inch (12.70 mm) 6-Digit Common Cathode GaAsP Display

### General Description

The NSB5931 is a 6-digit, 0.5 inch (12.70 mm) common cathode GaAsP display. Each digit is comprised of 7 segments with a right hand decimal point. Eight inputs are provided for selection of the appropriate segments and decimal (anodes) and 6 inputs for digits (cathodes) selection. The anodes are internally connected for multiplexing.

Simple interface circuit may be used for TTL, DTL or MOS operation. This unit is a direct replacement for the Litronix DL6500.

### Recommended Display Processing

The multi-digit series display is constructed on a standard printed circuit board substrate and covered with a plastic lens. The edge connector tab will stand 230°C for 5 seconds. Permanent damage to the display will result if lens temperature exceeds 70°C. Since the display is not hermetic, immersion of the entire package during flux and clean operation may cause condensation of flux or cleaner on the underside of the lens. Only the edge connectors should be immersed.

Rosin core solder, solid core solder, and low activity organic fluxes are recommended. Freon TF, Isopropanol, Methanol or Ethanol solvents are recommended only at room temperature and for short periods. The use of other solvents or elevated temperature use of the recommended solvents may cause permanent damage to the lens or display.

### Applications

- Industrial controls
- Data terminals
- Test equipment
- Point of sale
- Mini-computer readout
- Home consumer applications

### Absolute Ratings

Average Current per Segment	20 mA
Peak Current per Segment (100 μsec pulse)	150 mA
Reverse Voltage per Segment	3.0V max
Operating and Storage Temperatures	-20°C to +70°C
Relative Humidity at 35°C	98%
Terminal Temperature (Soldering, 5 seconds)	230°C max

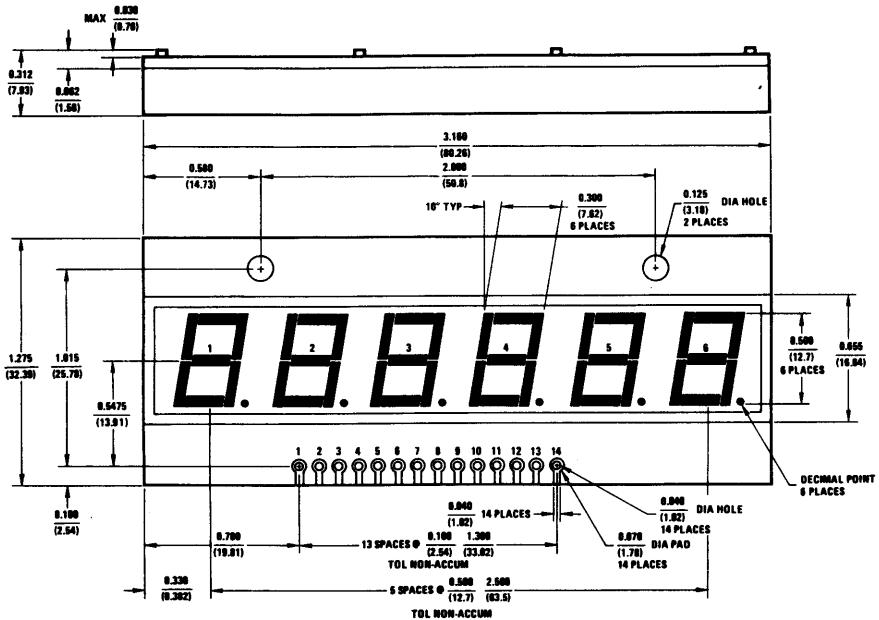
### Electrical and Optical Characteristics $T_A = 25^\circ\text{C}$ Room Temperature

PARAMETER	CONDITIONS	MIN	TYP	MAX	UNITS
Segment Light Intensity	10 mA/Seg. Avg.	0.10	0.20		mcd
Digit and D.P. Light Intensity	10 mA/Seg. Avg.	0.80	1.6		mcd
Segment Forward Voltage	10 mA/Seg.		1.7	2.0	V
Segment Reverse Voltage	100 μA/Seg.	3.0	8.0		V
Intensity Matching	10 mA/Seg. Avg.		±33		%
Peak Wavelength			660		nm
Spectral Width, Half Intensity			40		nm
Viewing Angle, Off Axis			60		Degrees

Pin Connections

PIN NO.	ELECTRICAL CONNECTION
1	Digit 1 Cathode
2	Digit 2 Cathode
3	Digit 3 Cathode
4	Segment A Anode
5	Segment F Anode
6	Segment B Anode
7	Segment G Anode
8	Digit 4 Cathode
9	Segment D Anode
10	Segment C Anode
11	Segment E Anode
12	Segment D.P. Anode
13	Digit 5 Cathode
14	Digit 6 Cathode

Physical Dimensions and Display Capability Outline inches (millimeters)



Note 1: Material: superpunch or approved equivalent.

Note 2: Tolerances: ±0.015/(0.38).

Segment Identification





**National  
Semiconductor**

## NSB7400, NSB7401, NSB7402, NSB7403, NSB7404, NSB7405 0.7 Inch 4-Digit LED Duplex Clock Displays

### General Description

The NSB7400 series is a 4-digit, 0.7 inch high GaAsP LED clock display, designed specifically for duplexed operation. These common anode displays are directly compatible with the MM5419, MM5420, MM5421, MM5422 and MM5455, MM5456, MM5457 duplex drive MOS/LSI integrated circuits. Electrical connection is by PCB type terminals on the edge of the display.

The optical design of this clock display series creates a distinct, easy-to-read display with a wide viewing angle and excellent ON/OFF contrast and segment uniformity. The beveled segments provide a pleasing numeral shape. The display features a diffuser tape or a red plastic lens (optional) over the reflector front surface for segment uniformity.

### Recommended Display Processing

The multidigit series display is constructed on a standard printed circuit board substrate and covered with a diffuser tape or a plastic lens. The edge connector tab will stand 230°C for 5 seconds. Permanent damage to the display will result if the diffuser tape or the plastic lens temperature exceeds 70°C. Since the display is not hermetic, immersion of the entire package during flux and clean operation may cause condensation of flux or cleaner on the underside of the diffuser tape or the plastic lens. Only the edge connectors should be immersed.

Rosin core solder, solid core solder, and low activity organic fluxes are recommended. Freon TF, Isopropanol, Methanol or Ethanol solvents are recommended only at room temperature and for short periods. The use of other

solvents or elevated temperature use of the recommended solvents may cause permanent damage to the display.

### Applications

- Alarm clocks
- Desk clocks
- Clock radios

### Features

- Large 0.7 inch numerals
- Small board size
- Pin-out compatible with MM5419 and MM5455 series clock integrated circuits
- PM indicator for 12-hour format
- 12-hour and 24-hour operations
- Colon indicator (single dot)
- Sleep/alarm indicator

### Absolute Ratings

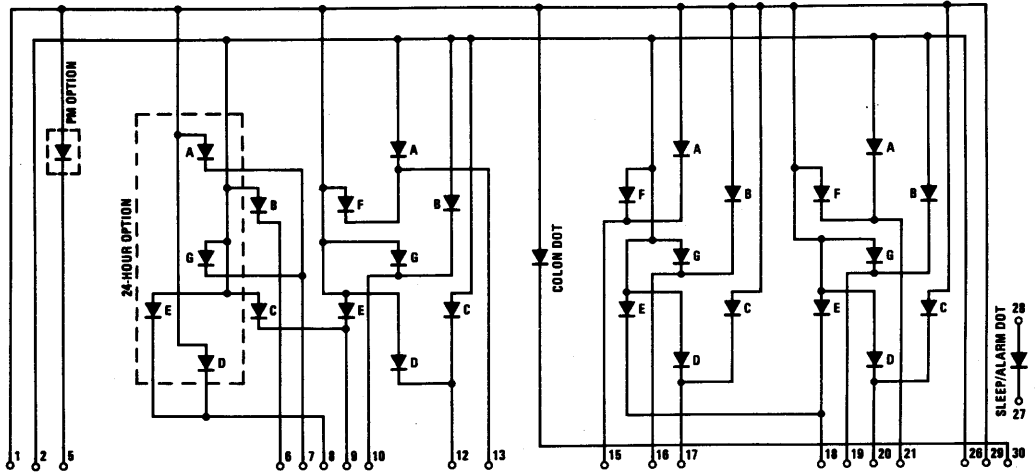
Average Current per Segment	20 mA max
Peak Current per Segment	75 mA max
Reverse Voltage per Segment	3.0V max
Operating and Storage Temperature	- 20°C to + 70°C
Relative Humidity at 35°C	98%
Lead Temperature (Soldering, 5 seconds)	230°C

### Electrical and Optical Characteristics $T_A = 25^\circ\text{C}$

Parameter	Conditions	Min	Typ	Max	Units
Segment Light Intensity (Peak)	10 mA/Segment Peak	0.10	0.20		mcd
Digit and DP Light Intensity (Peak)	10 mA/Segment Peak	0.80	1.6		mcd
Segment Forward Voltage	10 mA/Segment Peak		1.7	2.0	V
Segment Reverse Voltage	100 $\mu\text{A}$ /Segment	3.0	8.0		V
Peak Wavelength			660		nm
Spectral Width, Half-Intensity			40		nm
Viewing Angle, Off Axis			60		degrees
Intensity Matching	10 mA/Segment Average		$\pm 33$		%

NSB7400, NSB7401, NSB7402, NSB7403, NSB7404, NSB7405

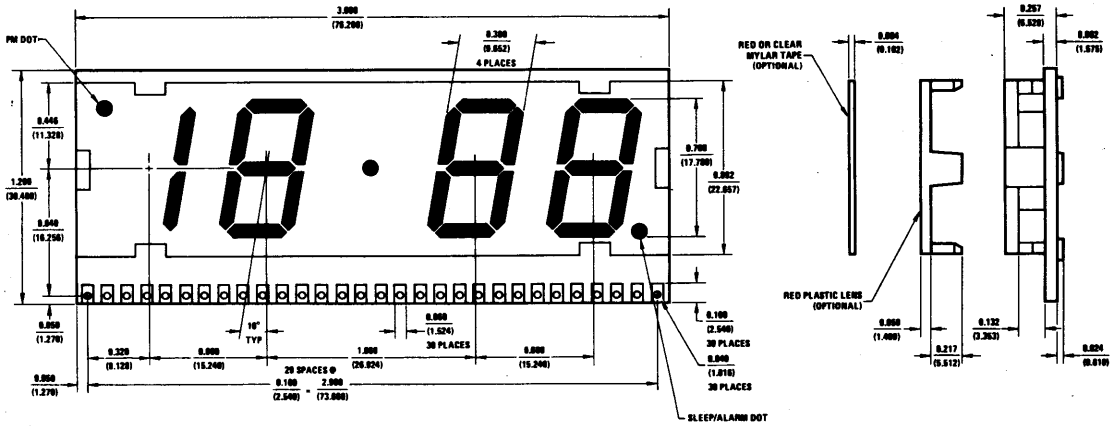
### Display Pin-Out Schematic



#### DISPLAY OPTIONS

Part #	Feature/Function
NSB7400	12-hour format with single piece reflector; with PM indicator; with red plastic lens.
NSB7401	24-hour format with single piece reflector; without PM indicator; with red plastic lens.
NSB7402	12-hour format with single piece reflector; with PM indicator; with red mylar tape (no lens).
NSB7403	12-hour format with single piece reflector; with PM indicator; with clear mylar tape (no lens).
NSB7404	24-hour format with single piece reflector; without PM indicator; with red mylar tape (no lens).
NSB7405	24-hour format with single piece reflector; without PM indicator; with clear mylar tape (no lens).

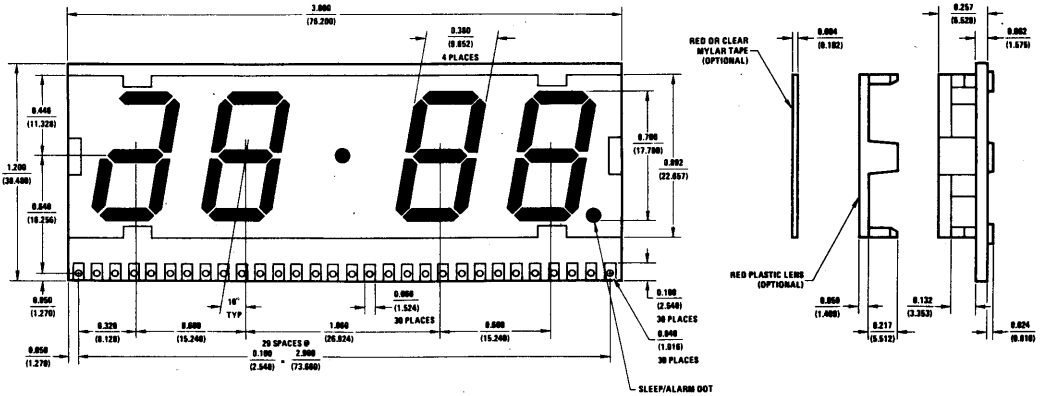
**Physical Dimensions** inches (millimeters) (NSB7400, NSB7402, NSB7403 12-hour format)



**Connection Table** (NSB7400, NSB7402, NSB7403 12-hour format)

Pin #	Electrical Connection	Pin #	Electrical Connection
1	Common Anode 1	16	Digit 3 Segments B, G Cathode
2	Common Anode 2	17	Digit 3 Segments C, D Cathode
3	No Connection	18	{ Digit 3 Segment E Cathode, Digit 4 Segment E Cathode
4	No Connection	19	Digit 4 Segments B, G Cathode
5	PM Cathode	20	Digit 4 Segments C, D Cathode
6	Digit 1 Segment B Cathode	21	Digit 4 Segments A, F Cathode
7	No Connection	22	No Connection
8	No Connection	23	No Connection
9	{ Digit 1 Segment C Cathode, Digit 2 Segment E Cathode	24	No Connection
10	Digit 2 Segments B, G Cathode	25	No Connection
11	No Connection	26	Common Anode 2
12	Digit 2 Segments C, D Cathode	27	Sleep/Alarm Dot Cathode
13	Digit 2 Segments A, F Cathode	28	Sleep/Alarm Dot Anode
14	No Connection	29	Common Anode 1
15	Digit 3 Segments A, F Cathode	30	Colon Dot Cathode

**Physical Dimensions** inches (millimeters) (NSB7401, NSB7404, NSB7405 24-hour format)



**Connection Table** (NSB7401, NSB7404, NSB7405 24-hour format)

Pin #	Electrical Connection	Pin #	Electrical Connection
1	Common Anode 1	16	Digit 3 Segments B, G Cathode
2	Common Anode 2	17	Digit 3 Segments C, D Cathode
3	No Connection	18	{ Digit 3 Segment E Cathode, Digit 4 Segment E Cathode
4	No Connection	19	Digit 4 Segments B, G Cathode
5	No Connection	20	Digit 4 Segments C, D Cathode
6	Digit 1 Segment B Cathode	21	Digit 4 Segments A, F Cathode
7	Digit 1 Segments A, G Cathode	22	No Connection
8	Digit 1 Segments D, E Cathode	23	No Connection
9	{ Digit 1 Segment C Cathode, Digit 2 Segment E Cathode	24	No Connection
10	Digit 2 Segments B, G Cathode	25	No Connection
11	No Connection	26	Common Anode 2
12	Digit 2 Segments C, D Cathode	27	Sleep/Alarm Dot Cathode
13	Digit 2 Segments A, F Cathode	28	Sleep/Alarm Dot Anode
14	No Connection	29	Common Anode 1
15	Digit 3 Segments A, F Cathode	30	Colon Dot Cathode





## NSN3XX, NSB3XXX 0.3" Multidigit LED Numeric Display Series

### General Description

Multidigit GaAsP LED reflective displays from National Semiconductor represent the latest in design advances in the 0.3" format. The series provides the designer with an effective, easy to implement answer to the need for an inexpensive large numeric display.

Basically 2-digit and 4-digit displays, the units are end stackable for applications requiring additional digits. When combined with the options for overflow, polarity and other indications, virtually all display requirements can be satisfied. Versatility is offered the designer with direct drive and multiplex versions in both the common anode and common cathode forms. Electrical contact is by PCB type terminals on the edges of the display.

The optical design of this display series creates a distinct easy-to-read display with a wide viewing angle, excellent ON-OFF contrast and segment uniformity.

### Features

- Multidigit packages prematched for brightness
- End stackable dual and quad formats to fit your application
- PC board mounted units for low cost
- Common anode, common cathode, multiplexed, or direct drive

### Applications

- Test and measurement equipment
- Consumer products
- Instrumentation
- Industrial controls
- Digital instruments
- Desk top calculator
- Clocks
- Elevator floor indicator
- TV channel indicator

### Absolute Ratings

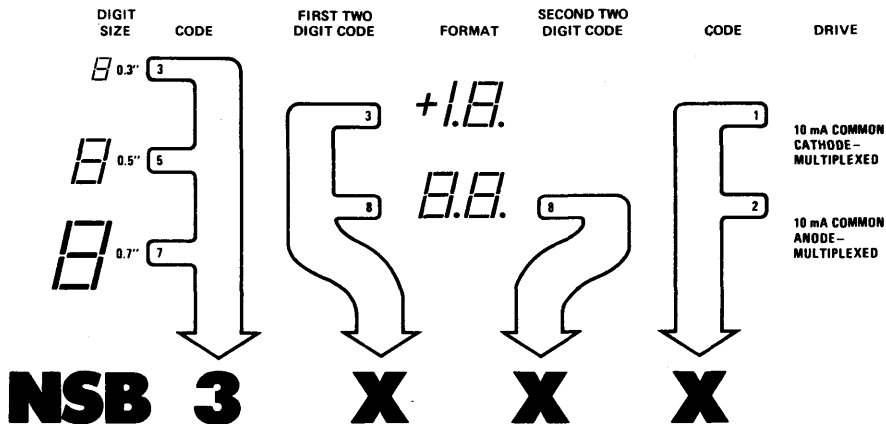
Average Current/Segment	20 mA max
Peak Current/Segment	75 mA max
Reverse Voltage/Segment	3.0V max
Operating and Storage Temperature	- 20°C to + 70°C
Relative Humidity at 35 °C	98%
Terminal Temperature (Soldering, 5 seconds)	230 °C

### Electrical and Optical Characteristics $T_A = 25^\circ\text{C}$

Parameter	Conditions	Min	Typ	Max	Units
Segment Light Intensity (Peak)	10 mA/Seg. Peak	0.10	0.20		mcd
Digit and DP Light Intensity (Peak)	10 mA/Seg. Peak	0.80	1.6		mcd
Segment Forward Voltage	10 mA/Seg. Peak		1.7	2.0	V
Segment Reverse Voltage	100 $\mu$ A/Seg.	3.0	8.0		V
Peak Wavelength			660		nm
Spectral Width, Half-Intensity			40		nm
Viewing Angle, Off Axis			60		degrees
Intensity Matching	10 mA/Seg. Avg.		$\pm 33$		%

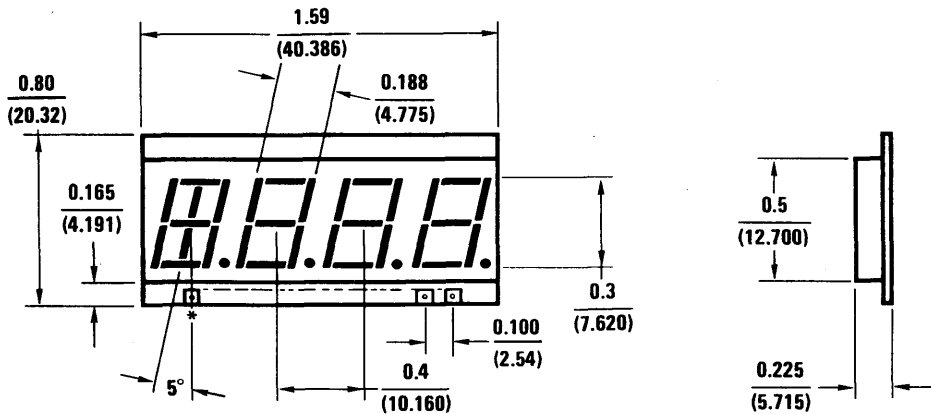


Available Display Formats (Quad Digits)



DEVICES CURRENTLY AVAILABLE	
NSB3382	+1.8.8.8.
NSB3881	8.8.8.8.
NSB3882	8.8.8.8.

Physical Dimensions inches (millimeters)



\* Pin 1 as shown, pin out follows counterclockwise

## Connection Tables (Dual Digits)

Pin Number	NSN334	NSN373	NSN374	NSN381	NSN382
1	Cathode J Digit 1	Anode G Digit 1	Cathode G Digit 1	Anode G	Cathode E
2	Cathode C Digit 1	Anode E Digit 1	Cathode E Digit 1	Anode E	Common Anode Digit 1
3	Cathode DP Digit 1	Anode D Digit 1	Cathode D Digit 1	NC	NC
4	Cathode G Digit 2	Anode C Digit 1	Cathode C Digit 1	Common Cathode Digit 1	Cathode C
5	Cathode E Digit 2	Anode G Digit 2	Cathode G Digit 2	Anode D	Common Anode Digit 2
6	Cathode D Digit 2	Anode E Digit 2	Cathode E Digit 2	Common Cathode Digit 2	Cathode D
7	Cathode C Digit 2	Anode D Digit 2	Cathode D Digit 2	Anode DP	Cathode DP
8	Cathode DP Digit 2	Anode C Digit 2	Cathode C Digit 2	Anode C	Cathode G
9	Cathode B Digit 2	Common Cathode Digits 1 and 2	Common Anode Digits 1 and 2	Anode B	Cathode B
10	NC	Anode B Digit 2	Cathode B Digit 2	NC	NC
11	Cathode A Digit 2	Anode A Digit 2	Cathode A Digit 2	NC	NC
12	Cathode F Digit 2	Anode F Digit 2	Cathode F Digit 2	NC	NC
13	Cathode B Digit 1	Anode B Digit 1	Cathode B Digit 1	Anode A	Cathode A
14	Common Anode Digits 1 and 2	Anode A Digit 1	Cathode A Digit 1	NC	NC
15	Cathode H Digit 1	Anode F Digit 1	Cathode F Digit 1	Anode F	Cathode F
16	Cathode G Digit 1	NC	NC	NC	NC

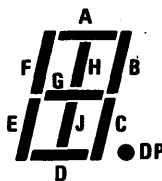
Device Type	Format	Drive
NSN334	+.B.	Common Anode—Direct
NSN373	BB No DP	Common Cathode—Direct
NSN374	BB No DP	Common Anode—Direct
NSN381	BB.	Common Cathode—Multiplexed
NSN382	BB.	Common Anode—Multiplexed

**Connection Tables** (Quad Digits)

Pin Number	NSB3382	NSB3881	NSB3882
1	NC	NC	NC
2	Cathode E	Anode E	Cathode E
3	Common Anode Digit 1	Common Cathode Digit 1	Common Anode Digit 1
4	Cathode J Digit 1	NC	NC
5	Cathode H Digit 1	NC	NC
6	Common Anode Digit 2	Common Cathode Digit 2	Common Anode Digit 2
7	Cathode D	Anode D	Cathode D
8	Cathode G	Anode G	Cathode G
9	NC	NC	NC
10	Common Anode Digit 3	Common Cathode Digit 3	Common Anode Digit 3
11	Cathode B	Anode B	Cathode B
12	Cathode A	Anode A	Cathode A
13	Cathode F	Anode F	Cathode F
14	Common Anode Digit 4	Common Cathode Digit 4	Common Anode Digit 4
15	Cathode DP	Anode DP	Cathode DP
16	Cathode C	Anode C	Cathode C

Device Type	Format	Drive
NSB3382	<i>1.B.B.B.</i>	Common Anode—Multiplexed
NSB3881	<i>B.B.B.B.</i>	Common Cathode—Multiplexed
NSB3882	<i>B.B.B.B.</i>	Common Anode—Multiplexed

**Segment Identification**



## Recommended Display Processing

The multidigit series display is constructed on a standard printed circuit board substrate and covered with a plastic lens. The edge connector tab will stand a temperature of 230°C for 5 seconds. The display lens area must not be elevated in temperature above 70°C. To do so will result in permanent damage to the display. Since the display is not hermetic, immersion of the entire package during flux and clean operations may cause condensation of flux or cleaner on the underside of the lens. It is recommended that only the edge connectors be immersed. Only rosin core solder, solid core solder, and low activity organic fluxes are recommended. Cleaning solvents are Freon TF, Isopropanol, Methanol, or Ethanol. These solvents are recommended only at room temperature and for short time periods. The use of other solvents or elevated temperature use of the recommended solvents may cause permanent damage to the lens or display.

## Special Formats

National is constantly adding new formats to its line of LED displays; For example:

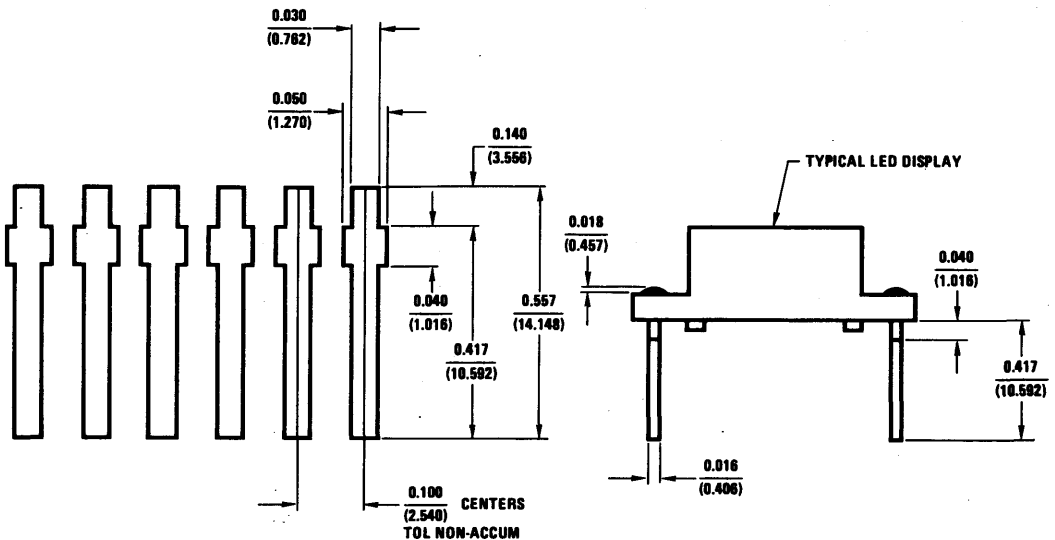
NSB3411 Clock Display 0.3 inch, 4-digit display, 24-hour format with colon and AM/PM indicator, common cathode multiplexed drive.

## Optional Pins

The standard LED numeric display offers a great deal of flexibility in mounting through the use of PCB edge connections. However, many designers prefer that pins be added to the PCB prior to shipping.

The standard pin used by NSC is outlined below and may be ordered by simply adding the designation "Flow 12" to the standard part number. Minimum order quantities and additional costs are involved, so check with the National Sales Office nearest you for more information.

For a complete discussion of various mounting techniques, consult the application note on "Mounting Techniques for Multidigit LED Numeric Displays;" AN-170.





## NSN5XX, NSB5XXX 0.5" Multidigit LED Numeric Display Series

### General Description

Multidigit GaAsP LED reflective displays from National Semiconductor represent the latest in design advances in the 0.5" format. The series provides the designer with an effective, easy to implement answer to the need for an inexpensive large numeric display.

Basically 2-digit and 4-digit displays, the units are end stackable for applications requiring additional digits. When combined with the options for overflow, polarity and other indications, virtually all display requirements can be satisfied. Versatility is offered the designer with direct drive and multiplex versions in both the common anode and common cathode forms. Electrical contact is by PCB type terminals on the edges of the display.

The optical design of this display series, creates a distinct easy-to-read display with a wide viewing angle, excellent ON-OFF contrast and segment uniformity.

### Features

- Multidigit packages prematched for brightness
- End stackable dual and quad formats to fit your application
- PC board mounted units for low cost
- Common anode, common cathode, multiplexed, or direct drive

### Applications

- Test and measurement equipment
- Consumer products
- Instrumentation
- Industrial controls
- Digital instruments
- Desk top calculator
- Clocks
- Elevator floor indicator
- TV channel indicator

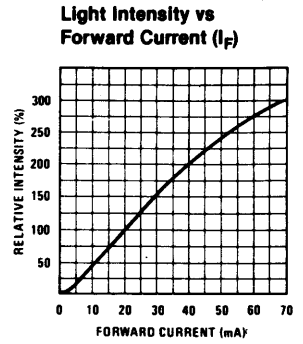
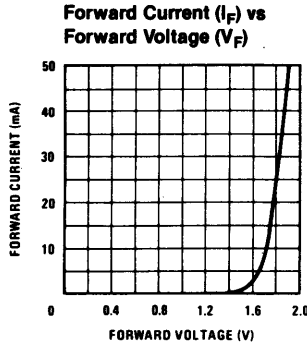
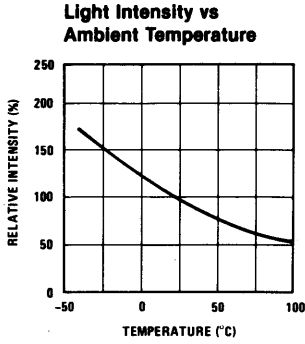
### Absolute Ratings

Average Current/Segment	20 mA max
Peak Current/Segment	75 mA max
Reverse Voltage/Segment	3.0V max
Operating and Storage Temperature	-20°C to +70°C
Relative Humidity at 35°C	98%
Terminal Temperature (Soldering, 5 seconds)	230°C

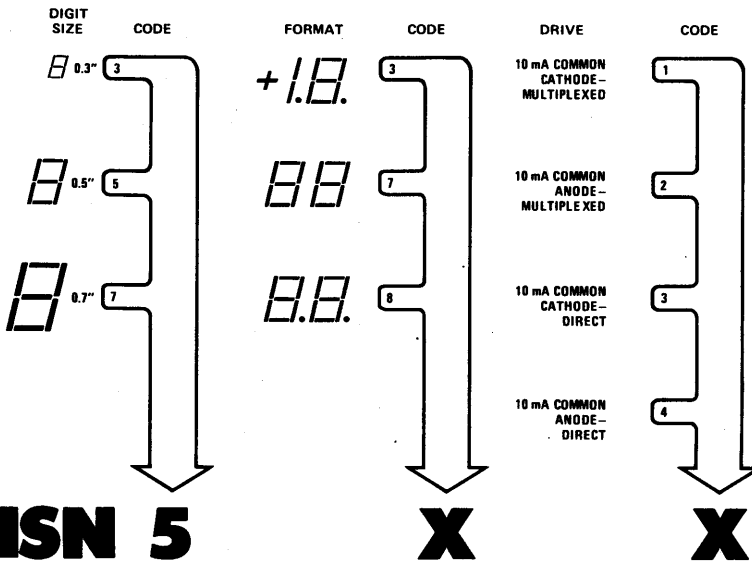
### Electrical and Optical Characteristics $T_A = 25^\circ\text{C}$

Parameter	Conditions	Min	Typ	Max	Units
Segment Light Intensity (Peak)	10 mA/Seg. Peak	0.10	0.20		mcd
Digit and DP Light Intensity (Peak)	10 mA/Seg. Peak	0.80	1.6		mcd
Segment Forward Voltage	10 mA/Seg. Peak		1.7	2.0	V
Segment Reverse Voltage	100 $\mu$ A/Seg.	3.0	8.0		V
Peak Wavelength			660		nm
Spectral Width, Half-Intensity			40		nm
Viewing Angle, Off Axis			60		degrees
Intensity Matching	10 mA/Seg. Avg.		$\pm 33$		%

## Performance Characteristics Curves

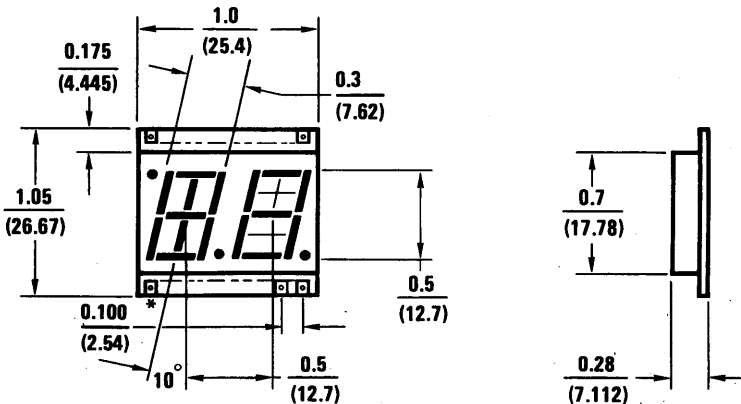


## Available Display Formats (Dual Digits)



DEVICES CURRENTLY AVAILABLE	
NSN534	+1.8.
NSN581	
NSN582	
NSN583	
NSN584	

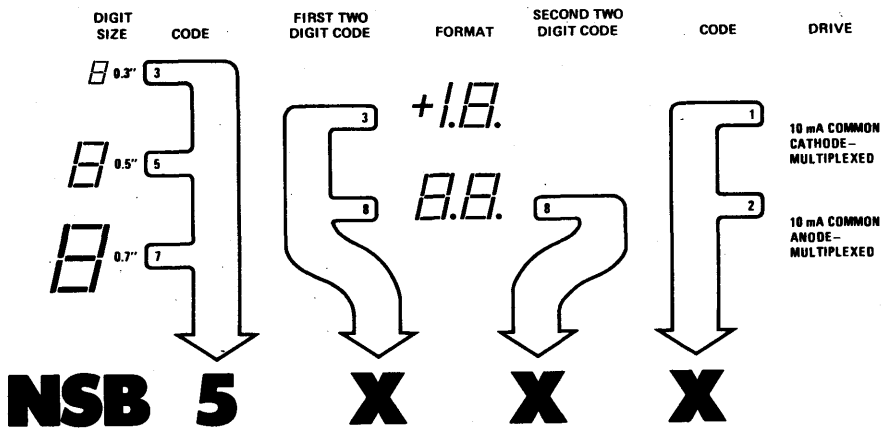
## Physical Dimensions inches (millimeters)



\* Pin 1 as shown, pin out follows counterclockwise

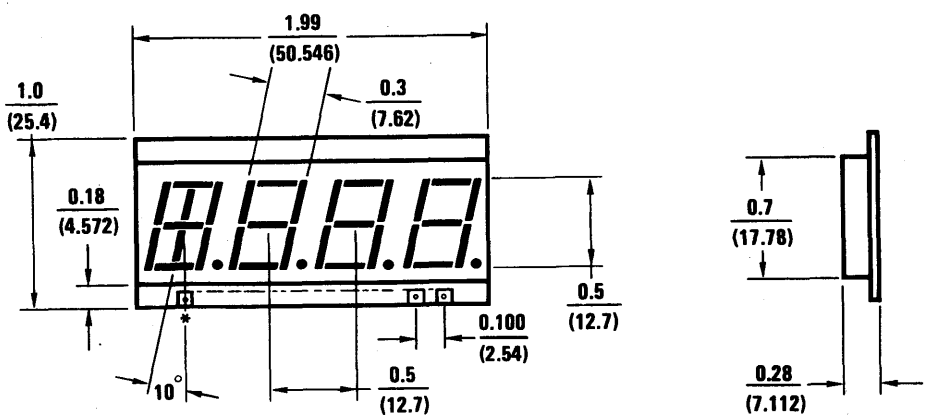


Available Display Formats (Quad Digits)



DEVICES CURRENTLY AVAILABLE	
NSB5382	+1.B.B.B.
NSB5881	B.B.B.B.
NSB5882	B.B.B.B.

Physical Dimensions inches (millimeters)



\* Pin 1 as shown, pin out follows counterclockwise

### Connection Tables (Dual Digits)

Pin Number	NSN534	NSN581	NSN582	NSN583	NSN584
1	NC	Anode G	Cathode G	Anode E Digit 1	Cathode E Digit 1
2	Cathode J Digit 1	Common Cathode Digit 1	Common Anode Digit 1	NC	NC
3	NC	Anode E	Cathode E	Anode D Digit 1	Cathode D Digit 1
4	Cathode C Digit 1	NC	NC	Anode DP Digit 1	Cathode C Digit 1
5	Cathode DP Digit 1	NC	NC	Anode C Digit 1	Cathode DP Digit 1
6	Cathode G Digit 2	NC	NC	Anode G Digit 2	Cathode G Digit 2
7	Cathode E Digit 2	Anode D	Cathode D	Anode E Digit 2	Cathode E Digit 2
8	Cathode D Digit 2	Anode DP	Cathode DP	Anode D Digit 2	Cathode D Digit 2
9	Cathode C Digit 2	Anode C	Cathode C	Anode DP Digit 2	Cathode C Digit 2
10	Cathode DP Digit 2	Common Cathode Digit 2	Common Anode Digit 2	Anode C Digit 2	Cathode DP Digit 2
11	Common Anode Digits 1 and 2	Anode B	Cathode B	Common Cathode Digits 1 and 2	Common Anode Digits 1 and 2
12	Cathode B Digit 2	NC	NC	Anode B Digit 2	Cathode B Digit 2
13	Cathode A Digit 2	NC	NC	Anode A Digit 2	Cathode A Digit 2
14	Cathode F Digit 2	NC	NC	Anode F Digit 2	Cathode F Digit 2
15	Cathode B Digit 1	NC	NC	Anode B Digit 1	Cathode B Digit 1
16	NC	NC	NC	Anode A Digit 1	Cathode A Digit 1
17	Cathode H Digit 1	Anode A	Cathode A	NC	NC
18	NC	Anode F	Cathode F	Anode F Digit 1	Cathode F Digit 1
19	NC	NC	NC	NC	NC
20	Cathode G Digit 1	NC	NC	Anode G Digit 1	Cathode G Digit 1

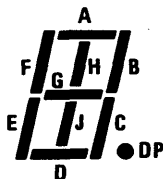
Device Type	Format	Drive
NSN534	<i>4.B</i>	Common Anode—Direct
NSN581	<i>B.B</i>	Common Cathode—Multiplexed
NSN582	<i>B.B</i>	Common Anode—Multiplexed
NSN583	<i>B.B</i>	Common Cathode—Direct
NSN584	<i>B.B</i>	Common Anode—Direct

## Connection Tables (Quad Digits)

Pin Number	NSB5382	NSB5881	NSB5882
1	Cathode A	Anode A	Cathode A
2	NC	NC	NC
3	Cathode D	Anode D	Cathode D
4	Common Anode Digit 1	Common Cathode Digit 1	Common Anode Digit 1
5	Cathode J Digit 1	NC	NC
6	Cathode H Digit 1	NC	NC
7	Common Anode Digit 2	Common Cathode Digit 2	Common Anode Digit 2
8	Cathode C	Anode C	Cathode C
9	NC	NC	NC
10	Common Anode Digit 3	Common Cathode Digit 3	Common Anode Digit 3
11	Cathode B	Anode B	Cathode B
12	Cathode F	Anode F	Cathode F
13	Cathode E	Anode E	Cathode E
14	Common Anode Digit 4	Common Cathode Digit 4	Common Anode Digit 4
15	Cathode DP	Anode DP	Cathode DP
16	Cathode G	Anode G	Cathode G

Device Type	Format	Drive
NSB5382	<i>+1.B.B.B.</i>	Common Anode—Multiplexed
NSB5881	<i>8.B.B.B.</i>	Common Cathode—Multiplexed
NSB5882	<i>8.B.B.B.</i>	Common Anode—Multiplexed

## Segment Identification



## Recommended Display Processing

The multidigit series display is constructed on a standard printed circuit board substrate and covered with a plastic lens. The edge connector tab will stand a temperature of 230°C for 5 seconds. The display lens area must not be elevated in temperature above 70°C. To do so will result in permanent damage to the display. Since the display is not hermetic, immersion of the entire package during flux and clean operations may cause condensation of flux or cleaner on the underside of the lens. It is recommended that only the edge connectors be immersed. Only rosin core solder, solid core solder, and low activity organic fluxes are recommended. Cleaning solvents are Freon TF, Isopropanol, Methanol, or Ethanol. These solvents are recommended only at room temperature and for short time periods. The use of other solvents or elevated temperature use of the recommended solvents may cause permanent damage to the lens or display.

## Special Formats

National is constantly adding new formats to its line of LED displays. Here are just a few of the products not listed on the guide which are available.

### Clock Formats

NSB5410 0.5 inch 4-digit display, 12-hour format with colon and AM/PM indicator, common cathode multiplexed drive.

NSB5430 Same as NSB5410 except direct drive.

### DVM Format

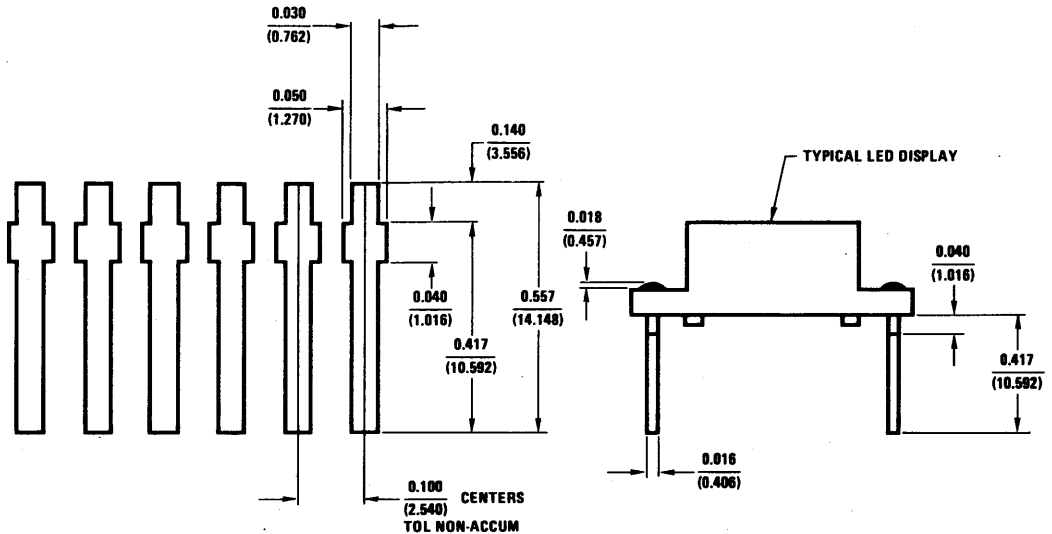
NSB5388 0.5 inch 3½ digit display pin compatible with National's ADD3500 DVM chip (see separate data sheet).

## Optional Pins

The standard LED numeric display offers a great deal of flexibility in mounting through the use of PCB edge connections. However, many designers prefer that pins be added to the PCB prior to shipping.

The standard pin used by NSC is outlined below and may be ordered by simply adding the designation "Flow 12" to the standard part number. Minimum order quantities and additional costs are involved, so check with the National Sales Office nearest you for more information.

For a complete discussion of various mounting techniques, consult the application note on "Mounting Techniques for Multidigit LED Numeric Displays," AN-170.



All dimensions are in inches (millimeters)

## NSN7XX, NSB7XXX 0.7" Multidigit LED Numeric Display Series

### General Description

Multidigit GaAsP LED reflective displays from National Semiconductor represent the latest in design advances in the 0.7" format. The series provides the designer with an effective, easy to implement answer to the need for an inexpensive large numeric display.

Basically 2-digit and 4-digit displays, the units are end stackable for applications requiring additional digits. When combined with the options for overflow, polarity and other indications, virtually all display requirements can be satisfied. Versatility is offered the designer with direct drive and multiplex versions in both the common anode and common cathode forms. Electrical contact is by PCB type terminals on the edges of the display.

The optical design of this display series creates a distinct easy-to-read display with a wide viewing angle, excellent ON-OFF contrast and segment uniformity.

### Features

- Multidigit packages prematched for brightness
- End stackable dual and quad formats to fit your application
- PC board mounted units for low cost
- Common anode, common cathode, multiplexed, or direct drive

### Applications

- Test and measurement equipment
- Consumer products
- Instrumentation
- Industrial controls
- Digital instruments
- Desk top calculator
- Clocks
- Elevator floor indicator
- TV channel indicator

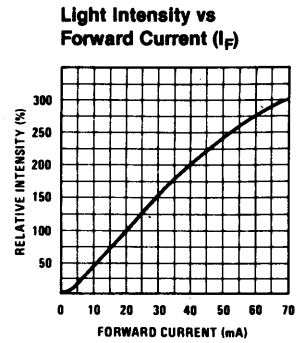
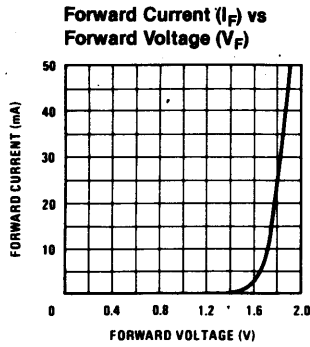
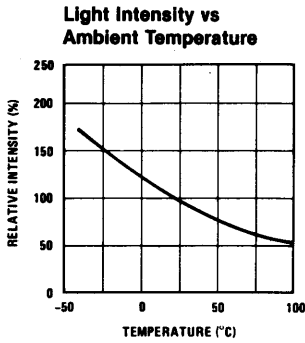
### Absolute Ratings

Average Current/Segment	20 mA max
Peak Current/Segment	75 mA max
Reverse Voltage/Segment	3.0V max
Operating and Storage Temperature	- 20°C to + 70°C
Relative Humidity at 35°C	98%
Terminal Temperature (Soldering, 5 seconds)	230°C

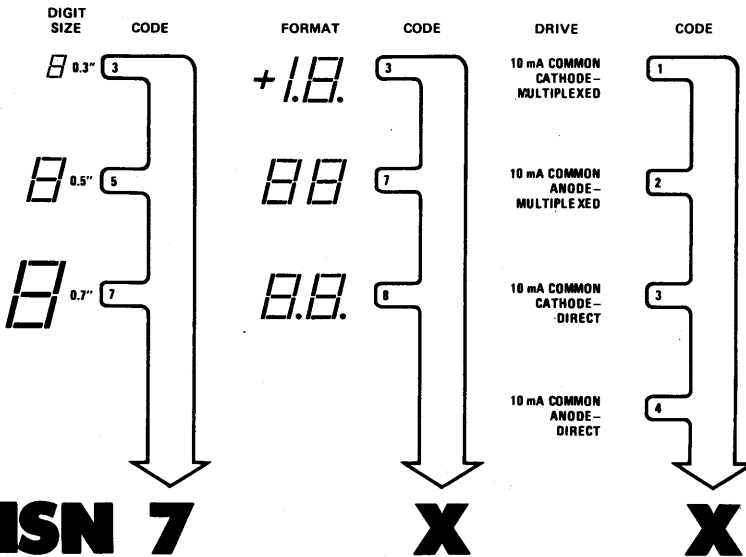
### Electrical and Optical Characteristics $T_A = 25^\circ\text{C}$

Parameter	Conditions	Min	Typ	Max	Units
Segment Light Intensity (Peak)	10 mA/Seg. Peak	0.10	0.20		mcd
Digit and DP Light Intensity (Peak)	10 mA/Seg. Peak	0.80	1.6		mcd
Segment Forward Voltage	10 mA/Seg. Peak		1.7	2.0	V
Segment Reverse Voltage	100 $\mu$ A/Seg.	3.0	8.0		V
Peak Wavelength			660		nm
Spectral Width, Half-Intensity			40		nm
Viewing Angle, Off Axis			60		degrees
Intensity Matching	10 mA/Seg. Avg.		$\pm 33$		%

### Performance Characteristics Curves

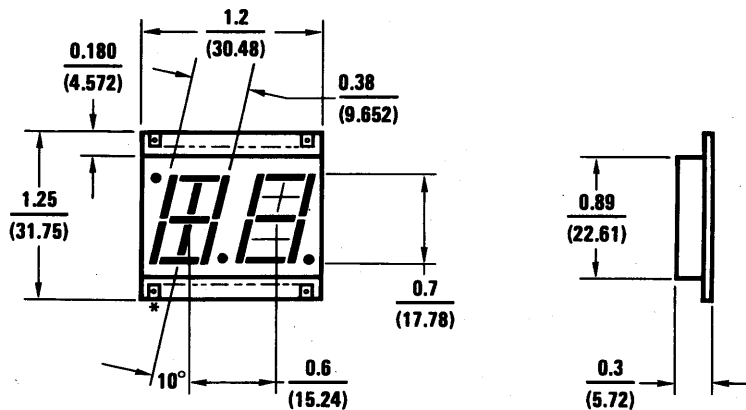


### Available Display Formats (Dual Digits)



DEVICES CURRENTLY AVAILABLE	
NSN734	+1.8.
NSN781	8.8
NSN782	8.8.
NSN783	8.8.
NSN784	8.8.

### Physical Dimensions inches (millimeters)



\* Pin 1 as shown, pin out follows counterclockwise



### Connection Tables (Dual Digits)

Pin Number	NSN734	NSN781	NSN782	NSN783	NSN784
1	NC	Anode G	Cathode G	Anode E Digit 1	Cathode E Digit 1
2	Cathode J Digit 1	Common Cathode Digit 1	Common Anode Digit 1	NC	NC
3	NC	Anode E	Cathode E	Anode D Digit 1	Cathode D Digit 1
4	Cathode C Digit 1	NC	NC	Anode C Digit 1	Cathode C Digit 1
5	Common Anode Digit 1	NC	NC	Common Cathode Digit 1	Common Anode Digit 1
6	Cathode DP Digit 1	NC	NC	Anode DP Digit 1	Cathode DP Digit 1
7	NC	NC	NC	NC	NC
8	Cathode E Digit 2	NC	NC	Anode E Digit 2	Cathode E Digit 2
9	Cathode D Digit 2	Anode D	Cathode D	Anode D Digit 2	Cathode D Digit 2
10	Cathode C Digit 2	Common Cathode Digit 2	Common Anode Digit 2	Anode C Digit 2	Cathode C Digit 2
11	Common Anode Digit 2	Anode DP	Cathode DP	Common Cathode Digit 2	Common Anode Digit 2
12	Cathode DP Digit 2	Anode C	Cathode C	Anode DP Digit 2	Cathode DP Digit 2
13	Cathode B Digit 2	Anode B	Cathode B	Anode B Digit 2	Cathode B Digit 2
14	Cathode A Digit 2	NC	NC	Anode A Digit 2	Cathode A Digit 2
15	Cathode F Digit 2	NC	NC	Anode F Digit 2	Cathode F Digit 2
16	Cathode G Digit 2	NC	NC	Anode G Digit 2	Cathode G Digit 2
17	NC	NC	NC	NC	NC
18	Cathode G Digit 1	Anode A	Cathode A	Anode G Digit 1	Cathode G Digit 1
19	Cathode B Digit 1	NC	NC	Anode B Digit 1	Cathode B Digit 1
20	NC	NC	NC	Anode A Digit 1	Cathode A Digit 1
21	Cathode H Digit 1	NC	NC	NC	NC
22	NC	NC	NC	Anode F Digit 1	Cathode F Digit 1
23	NC	Anode F	Cathode F	NC	NC
24		NC	NC		

Device Type	Format	Drive
NSN734	<i>1.B</i>	Common Anode—Direct
NSN781	<i>B.B</i>	Common Cathode—Multiplexed
NSN782	<i>B.B</i>	Common Anode—Multiplexed
NSN783	<i>B.B</i>	Common Cathode—Direct
NSN784	<i>B.B</i>	Common Anode—Direct

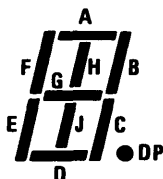


## Connection Tables (Quad Digits)

Pin Number	NSB7382	NSB7881	NSB7882
1	NC	NC	NC
2	Cathode H Digit 1	NC	NC
3	Cathode J Digit 1	NC	NC
4	Common Anode Digit 1	Common Cathode Digit 1	Common Anode Digit 1
5	Cathode F	Anode F	Cathode F
6	Common Anode Digit 2	Common Cathode Digit 2	Common Anode Digit 2
7	Cathode C	Anode C	Cathode C
8	Cathode DP	Anode DP	Cathode DP
9	Cathode G	Anode G	Cathode G
10	Cathode E	Anode E	Cathode E
11	Common Anode Digit 3	Common Cathode Digit 3	Common Anode Digit 3
12	Cathode B	Anode B	Cathode B
13	Cathode A	Anode A	Cathode A
14	Common Anode Digit 4	Common Cathode Digit 4	Common Anode Digit 4
15	Cathode D	Anode D	Cathode D

Device Type	Format	Drive
NSB7382	<i>1.B.B.B.</i>	Common Anode—Multiplexed
NSB7881	<i>B.B.B.B.</i>	Common Cathode—Multiplexed
NSB7882	<i>B.B.B.B.</i>	Common Anode—Multiplexed

## Segment Identification



## Recommended Display Processing

The multidigit series display is constructed on a standard printed circuit board substrate and covered with a plastic lens. The edge connector tab will stand a temperature of 230°C for 5 seconds. The display lens area must not be elevated in temperature above 70°C. To do so will result in permanent damage to the display. Since the display is not hermetic, immersion of the entire package during flux and clean operations may cause condensation of flux or cleaner on the underside of the lens. It is recommended that only the edge connectors be immersed. Only rosin core solder, solid core solder, and low activity organic fluxes are recommended. Cleaning solvents are Freon TF, Isopropanol, Methanol, or Ethanol. These solvents are recommended only at room temperature and for short time periods. The use of other solvents or elevated temperature use of the recommended solvents may cause permanent damage to the lens or display.

## Special Formats

National is constantly adding new formats to its line of LED displays. For example:

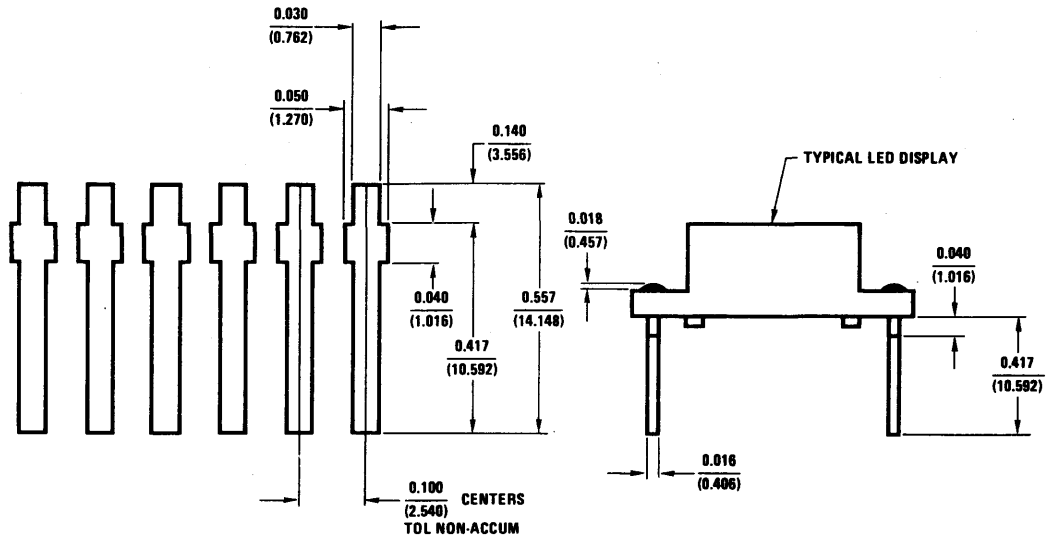
NSB7403 Duplex Drive Clock Format.

## Optional Pins

The standard LED numeric display offers a great deal of flexibility in mounting through the use of PCB edge connections. However, many designers prefer that pins be added to the PCB prior to shipping.

The standard pin used by NSC is outlined below and may be ordered by simply adding the designation "Flow 12" to the standard part number. Minimum order quantities and additional costs are involved, so check with the National Sales Office nearest you for more information.

For a complete discussion of various mounting techniques, consult the application note on "Mounting Techniques for Multidigit LED Numeric Displays," AN-170.



All dimensions are in inches (millimeters)

# Mounting Techniques for Multidigit LED Numeric Displays

National Semiconductor  
Application Note 170  
Dick Schubert  
November 1976



AN-170 Mounting Techniques for Multidigit LED Numeric Displays

## Introduction

Designed to meet the requirements of a wide range of applications, NSC's printed circuit board mounted numerics feature:

- End stackable 2, 4, 5 and 6-digit packages
- 0.3-, 0.5-, and 0.7-inch digit sizes
- Common anode and common cathode versions
- Direct and multiplex drive

Equally important to all these features is the ease with which the designer can interconnect the display to the rest of a system. This was a primary design goal for the multidigit numerics and it is the purpose of this application note to pass on some of our research to the designer. It should be noted that this is not intended to be an extensive study, but rather is intended to provide direction toward the many possibilities available to the designer.

## Electrical and Optical Specifications

Before treating the problem of mechanical and electrical interconnection, a short statement of the basic properties of the display is in order. For further details see the product data sheet.

### Electrical

All displays in the multidigit numeric series, whether common anode or common cathode, direct drive or multiplex, share the same electrical characteristics.

	Min	Typ	Max	Units
Forward Voltage, $V_f$ , @ 10 mA		1.7	2.0	V
Reverse Voltage, $V_r$ , @ 100 $\mu$ A	3.0	8.0		V
Digit Light Intensity @ 10 mA	0.8	1.6		mcd

The choice between common anode and common cathode should merely be a matter of convenience of interface to the rest of the electrical design. However, the choice between multiplex and direct drive is more complex and quite fundamental to any design. It is not within the scope of this application note to discuss the tradeoffs between direct and multiplex drive except for one caution to the designer: when multiplexing, care should be exercised to not exceed the peak segment current ratings of the device. For example:

Desired average segment current — 15 mA

Peak current for a 4-digit display:

$$4 \times 15 \text{ mA} = 60 \text{ mA}$$

Peak current for a 6-digit display:

$$6 \times 15 \text{ mA} = 90 \text{ mA}$$

Therefore, for applications requiring more than 75 mA peak current when multiplexed, direct drive is suggested.

### Optical Characteristics

As with the electrical specifications, the multidigit numerics all have common optical properties. This directly results from the material used and techniques of manufacture.

Characteristic	Typ	Units
Wavelength	660	nm
Spectral Width, Half Intensity	40	nm
Viewing Angle, Off Axis	60	degrees
Intensity (digit)	1.6	mcd
Intensity Matching	±33	%

Contrast enhancement can be achieved by using a lens over the display that has a peak transmission point centered around 660 nm.

## Mechanical Design

The principal concern of a mechanical designer when "designing in" a display is the functional relationship of the display to the design. This relationship is the primary factor in determining the means of mechanical support and electrical interconnection for the display and varies tremendously from one application to another.

In nearly all cases, more than one answer presents itself, at which point the designer must tradeoff mechanical and/or electrical considerations with cost. Cost can vary considerably, ranging from inexpensive pin schemes at less than one cent per connection to connectors costing over ten cents per connection.

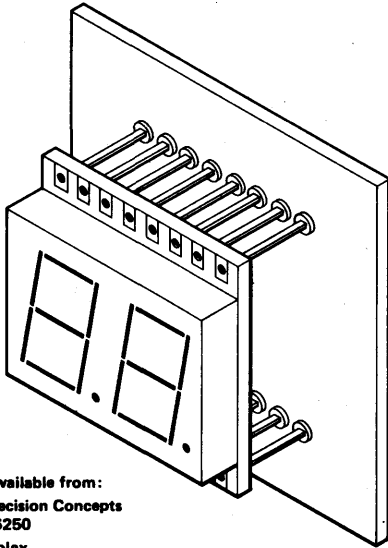
### Examples:

#### 1. TV Channel Indicator – 2 Digits – NSN Dual Series

##### Design Constraints:

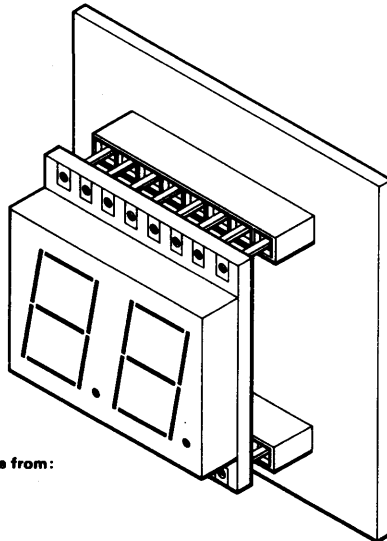
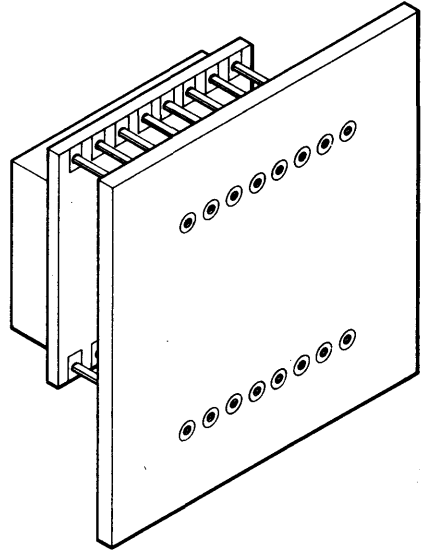
1. One display mounted parallel and adjacent to the logic board.

2. Support to be provided by the interconnection.



pins available from:

1. Precision Concepts  
#6250
2. Molex  
KK-100 Series
3. AMP Inc.  
Mod. II



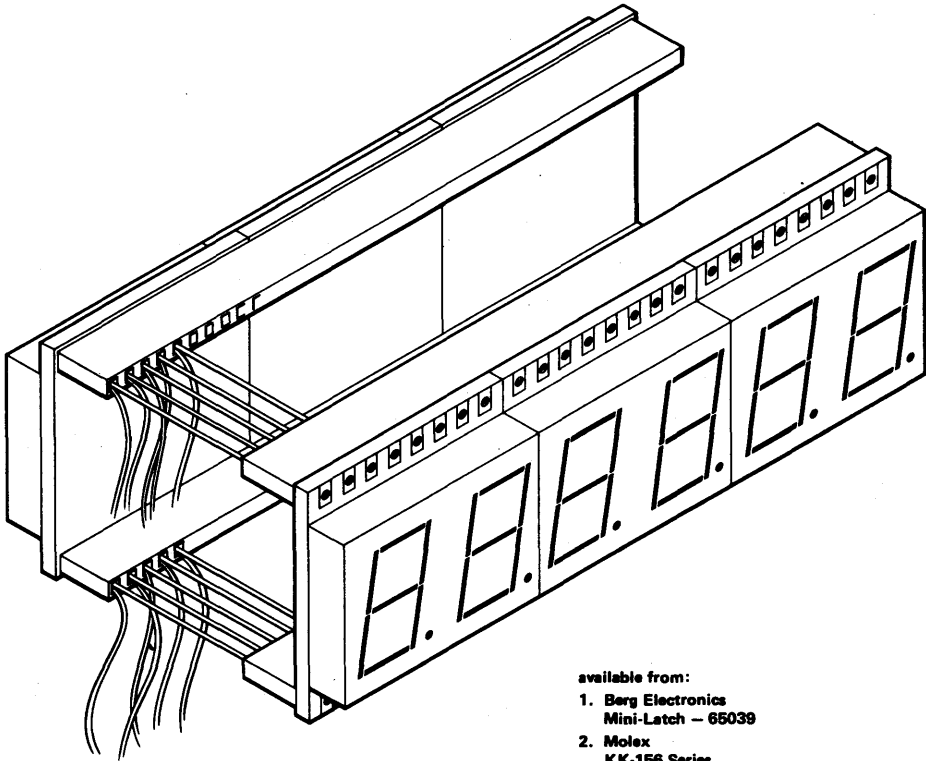
connectors available from:

1. Molex  
KK-156 Series
2. AMP Inc.  
Mod. IV

**2. Cash Register – Two 6-Digit Displays – NSN Dual Series**

**Design Constraints:**

1. Two sets of 3 dual-digit displays mounted back-to-back.
2. Displays are removed from the immediate vicinity of the logic board.
3. Support does not have to be provided by the connection since it can be part of the case design.
4. Serviceability an important consideration.



available from:

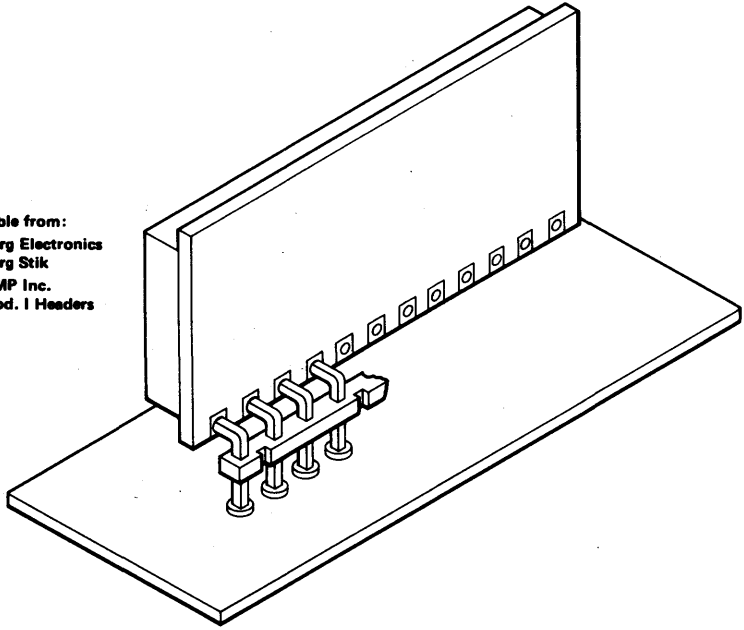
1. Berg Electronics  
Mini-Latch – 65039
2. Molex  
KK-156 Series

**3. Digital Voltmeter – 3½-Digit Display – NSB Multiplex Series**

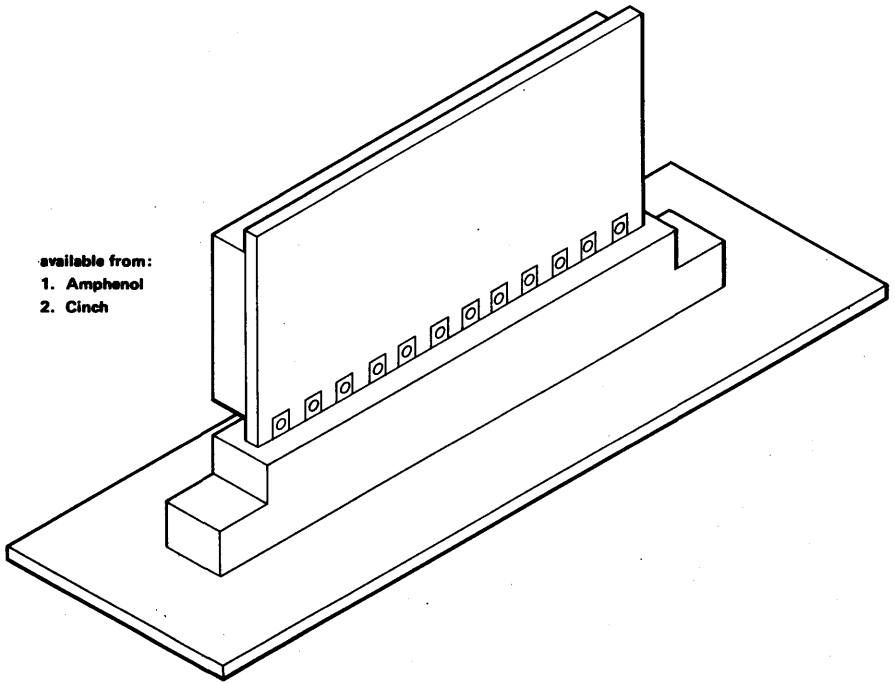
Design Constraints:

- 1. One display mounted perpendicular to the logic board.
- 2. Display support to be provided by the interconnection.
- 3. The interconnection should use minimum space.

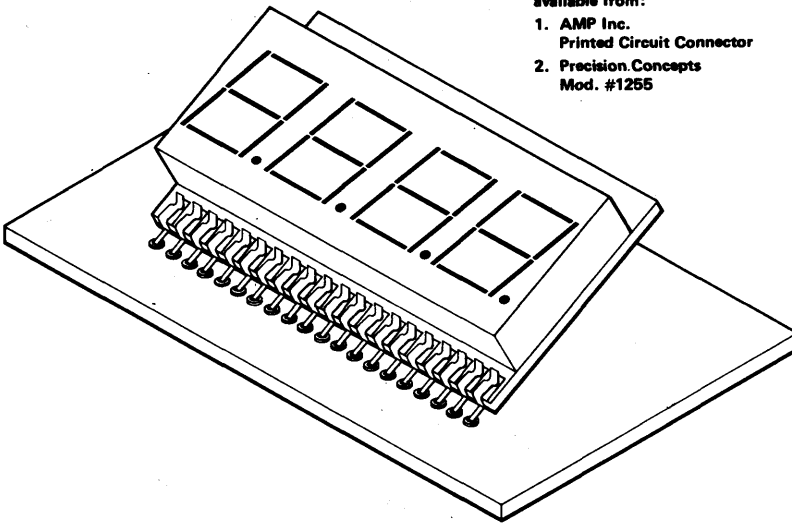
available from:  
1. Berg Electronics  
Berg Stik  
2. AMP Inc.  
Mod. I Headers



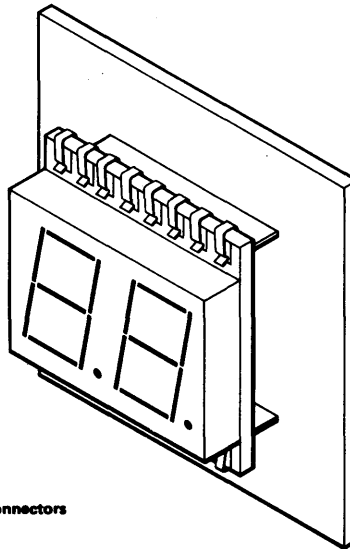
available from:  
1. Amphenol  
2. Cinch



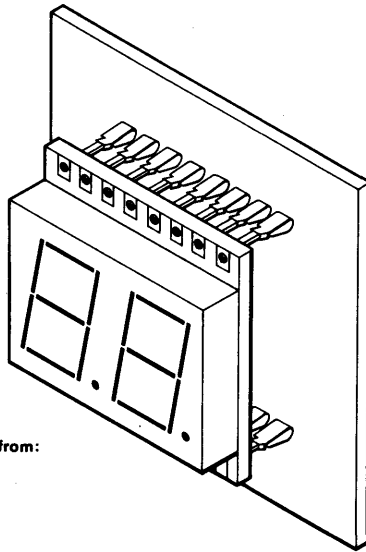
Further Design Examples



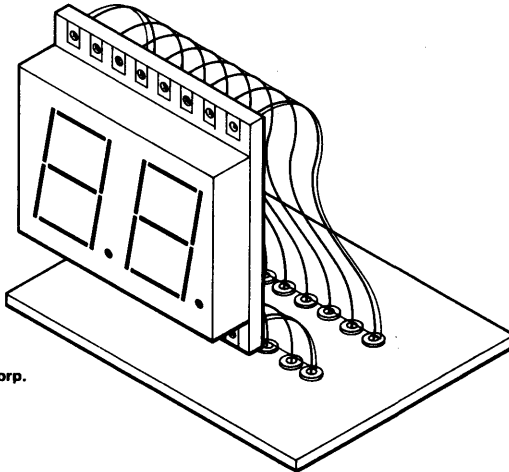
available from:  
1. AMP Inc.  
Printed Circuit Connector  
2. Precision Concepts  
Mod. #1255



available from:  
1. AMP Inc.  
Printed Circuit Connectors



PCB connectors available from:  
Molex  
Soldercon Series



available from:  
1. Ansley Electronics Corp.  
"Flex Strip"  
2. AMP Inc.  
Jumper Cable Ass'y

## Recommended Display Processing

The multidigit display is constructed on a standard printed circuit board substrate and covered with a plastic lens. The edge connector tab will stand a temperature of 230°C for 5 seconds. The display lens area must not be elevated in temperature above 70°C. To do so will result in permanent damage to the display. Since the display is not hermetic, immersion of the entire package during flux and clean operations may cause condensation of flux or cleaner on the underside of the lens. It is recommended that only the edge connectors be immersed. Only rosin core solder, solid core solder, and low activity organic fluxes are recommended. Cleaning

solvents are Freon TF, isopropanol, methanol, or ethanol. These solvents are recommended only at room temperature and for short time periods. The use of other solvents or elevated temperature use of the recommended solvents may cause permanent damage to the lens or display.

This application note is not intended to imply specific endorsement or warranty of a manufacturer's product by National Semiconductor. In addition, it is not an inclusive list of manufacturers, and the designers will by research find additional sources and a wide range of prices.





# Integrated Displays

Currently, under development at National is a product line of integrated displays which combines state-of-the-art integrated circuits with the latest in display/readout devices.

Three devices are scheduled for release in late 1979:

- 1) Bargraph array with driver
- 2) 0.3" display with serial input driver
- 3) 0.5" display with serial input driver

Other devices which are in early planning or layout stage are:

- 1) Alpha numeric display with decoder/driver
- 2) Vu meter display
- 3) Other bargraph-with-driver displays
- 4) Displays with data-bus compatible drivers

Details on these and other National products will be distributed when available through National's

sales offices or franchised distributors.

Following is a brief description of the first three products to be introduced:

- 1) NSM3914, NSM3915, NSM3916

The NSM3914 series of 10-element bargraph arrays with National's LM3915 or LM3916 linear integrated circuit as the on-board driver is described in the preliminary data sheet on the following pages.

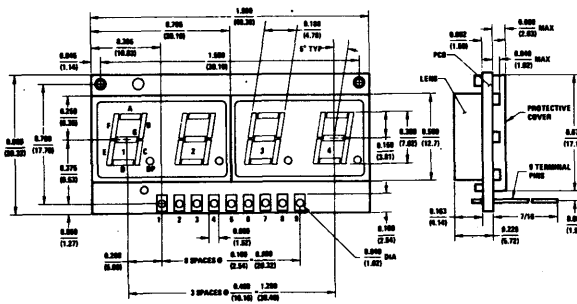
- 2) NSM4000A

A 0.3 inch, 4 digit array with National's MM5450 35-bit, serial-input LED driver as the on-board driver (outline drawing shown below).

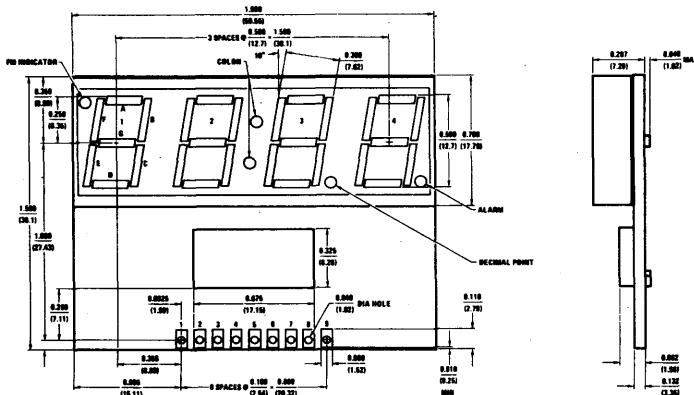
- 3) NSM4001

Similar to the NSM4000 but with a 0.5 inch, 4-digit display (outline drawing shown below).

## OUTLINE DRAWINGS\*



NSM4000A



NSM4001

\* Preliminary data



# NSM3914, NSM3915, NSM3916 Series End-Stackable LED Bar Graph Array with Driver

## General Description

The NSM3914, NSM3915, NSM3916 series are functional replacements for a variety of conventional meters. Each combines a 10-element red LED linear array and a monolithic integrated circuit display driver. The driver circuits, similar to the LM3914, LM3915, LM3916 series, light successive LEDs as the analog input voltage level increases past prescaled threshold points.

The NSM3914 provides a linear analog display, as internal threshold points are linearly scaled. A logarithmic display is provided by the NSM3915, as threshold points are set on 3 dB intervals. The NSM3916 is a variation of the logarithmic display; the VU meter function is provided by using threshold points at common VU levels.

The driver circuit contains a stable, adjustable voltage reference which precisely sets LED thresholds independently of supply voltage. Current drives to the LEDs are regulated and programmable, eliminating the need for many resistors. The entire display array can operate from supply voltages as low as 3V to as high as 24V. The internal voltage reference is also connected to an accurate 10-step voltage divider, supplying reference voltages for 10 individual comparators. These comparators switch as the signal voltage exceeds the established thresholds as described above. The typical overall inaccuracy (deviation from ideal) is typically within 1% for the NSM3914 and below 1 dB for the NSM3915 and NSM3916. A high impedance input buffer accepts signals down to ground, yet

protects against signal inputs of 35V above or below ground. A single (mode) pin changes the display from a bar graph to a moving dot. Additional information regarding the internal voltage reference, LED current programming mode selection, and application hints are given in the LM3914, LM3915, LM3916 data sheets.

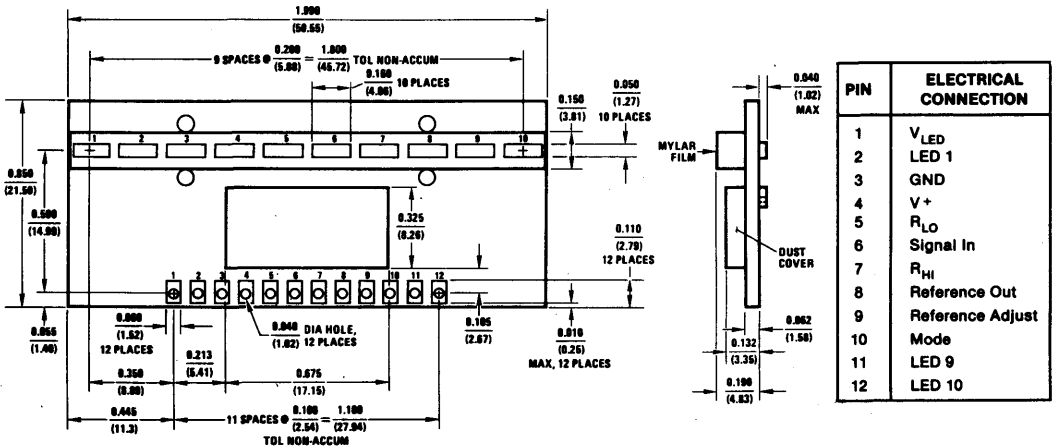
## Features

- Packages are end-stackable for expanded displays
- Can be cascaded to 10 arrays (100 bar graph element)
- Linear, logarithmic, and VU meter functions performed
- Bar or dot display mode externally selectable by user
- LED current programmable from 2 mA to 30 mA
- Stable, internal voltage reference for full-scale analog inputs from 1.2V to 12V
- Inputs operate down to ground
- Signal input withstands 35V without damage or false outputs

## Applications

- Power meter in stereo systems
- S meter in ham and CB radios
- VU meter in tape recorders
- Process control meters
- Replacement for edge meters

## Physical Dimensions and Pin Connections inches (millimeters)



## Absolute Maximum Ratings (Note 3)

Power Dissipation-Driver (Note 1)	500 mW	Signal Input Current (With Overvoltage Applied)	± 3 mA
V <sup>+</sup> Voltage	24V	Operating Temperature Range	0°C to 70°C
V <sub>LED</sub> Voltage	24V	Storage Temperature Range	-20°C to 70°C
Input Signal Overvoltage (Note 2)	± 35V	Lead Temperature (Soldering, 5 seconds)	230°C
Voltage on Resistor String	-100 mV to V <sup>+</sup>		
Reference Load Current	10 mA		

## Optical and Electrical Characteristics (Notes 3 and 4)

Parameter	Conditions	Min	Typ	Max	Units	
LED Segment Intensity	V <sup>+</sup> = 12.0V, V <sub>LED</sub> = 4.5V, I <sub>REF</sub> = 1.0 mA	0.10	0.20		mcd	
LED Intensity Matching (All Segments On)	V <sub>IN</sub> ≥ 10V, V <sup>+</sup> = 12.0V, V <sub>LED</sub> = 3.0V, I <sub>REF</sub> = 1.0 mA		± 33		%	
LED Current/Segment	V <sup>+</sup> = 12.0V, V <sub>LED</sub> = 4.5V, I <sub>REF</sub> = 1.0 mA		10		mA	
Peak Wavelength			660		nm	
Voltage Reference Output	0.10 mA ≤ I <sub>REF</sub> ≤ 4.0 mA, V <sup>+</sup> = 12.0V, V <sub>LED</sub> = 4.5V	1.2	1.28	1.34	V	
Signal Input Bias Current			10	100	nA	
Supply Current (V <sup>+</sup> Lead)	V <sup>+</sup> = 5V to 20V, I <sub>REF</sub> = 1.0 mA		6	10	mA	
Absolute Accuracy At Each Threshold Point	NSM3914	Deviation from Straight Line through First and Last Threshold Point (Note 5)		- 5	5	%
	NSM3915	V <sub>IN</sub> = - 3 to - 18 dB (Note 6)		- 1	1.5	dB
		V <sub>IN</sub> = - 21 to - 27 dB (Note 6)		- 2	2	dB
	NSM3916	V <sub>IN</sub> = + 3 to - 7 dB (Note 7)		- 1	1.5	dB
		V <sub>IN</sub> = - 10 to - 20 dB (Note 7)		- 2	2	dB

**Note 1:** Driver dissipation is given by:  $P_{DR} = (V_{LED} - 1.7V) I_{LED} (Total) + (V_{V+} - 1.7V) 10 \text{ mA}$  where  $V_{LED}$  is the LED supply voltage, 1.7V is the nominal individual LED voltage drop and 10 mA is the maximum current of the V<sup>+</sup> supply.

**Note 2:** The addition of a 39k resistor in series with the input signal allows ± 100V signals without damage.

**Note 3:** Unless otherwise stated, all specifications apply with the following conditions: V<sup>+</sup> (supply) 3V to 20V; Input signal range 0.015V to (V<sup>+</sup> - 1.5V) with a maximum of 12 V<sub>DC</sub>; Comparator divider voltages, same limits; T<sub>A</sub> = 25°C; Reference load current, 80 μA minimum.

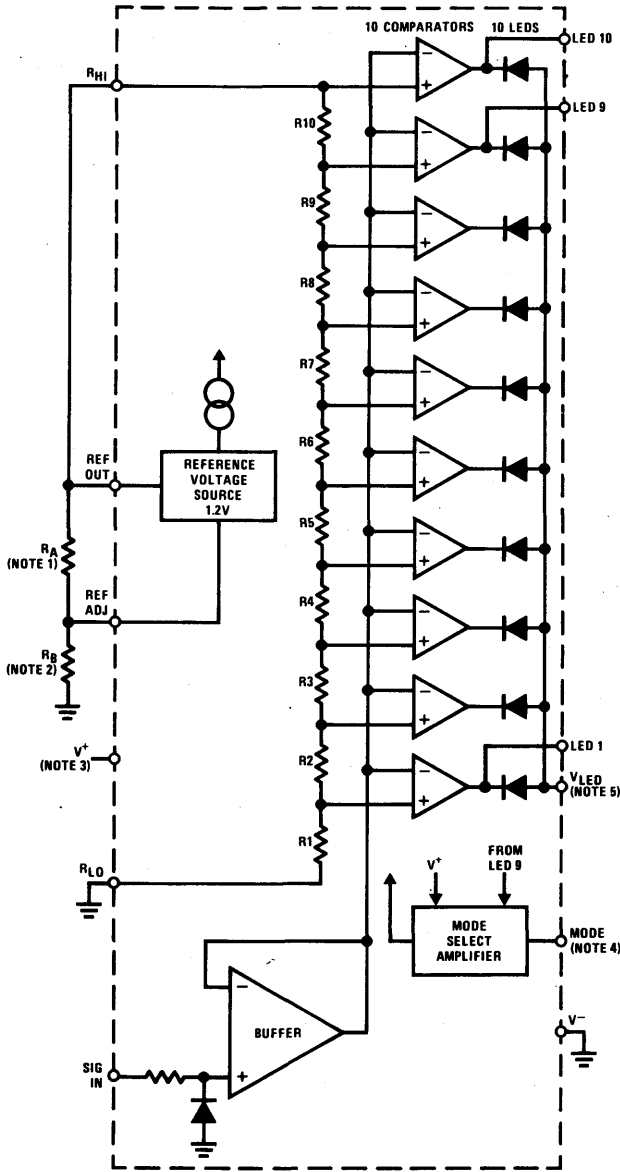
**Note 4:** The following situations can lead to incorrect operation (a) V<sub>LED</sub> exceeding V<sup>+</sup> or more than 14V below V<sup>+</sup>; (b) signal and comparator voltage divider becoming higher than the limits of Note 1; (c) reference load capacitance above 0.05 μF; (d) reference current loading above 5 mA.

**Note 5:** Divider non-linearity is measured with R<sub>LO</sub> at 0.000V and R<sub>HI</sub> at 10.000 V<sub>DC</sub>. (At lower divider voltages, buffer and comparator offset voltages may add significant error).

**Note 6:** Accuracy is measured referred to 0 dB = 10.000 V<sub>DC</sub> at signal input, with R<sub>LO</sub> at 0.000V and R<sub>HI</sub> at 10.000 V<sub>DC</sub>. (At lower full-scale voltages, buffer and comparator offset voltages may add significant error).

**Note 7:** Accuracy is measured referred to 3 dB = 10.000 V<sub>DC</sub> at signal input, with R<sub>LO</sub> at 0.000V and R<sub>HI</sub> at 10.000 V<sub>DC</sub>. (At lower full-scale voltages, buffer and comparator offset voltages may add significant error).

# Block and Connection Diagram



**TYPICAL RESISTOR STRING VALUES**

Resistor	NSM3914	NSM3915	NSM3916
R1	1.00k	1.0k	0.708k
R2	1.00k	0.41k	1.531k
R3	1.00k	0.59k	0.923k
R4	1.00k	0.83k	0.819k
R5	1.00k	1.17k	1.031k
R6	1.00k	1.66k	1.298k
R7	1.00k	2.34k	0.769k
R8	1.00k	3.31k	0.864k
R9	1.00k	4.69k	0.970k
R10	1.00k	6.63k	1.087k
Total	10k	22.6k	10k

**Note 1:**  $R_A$  determines  $I_{LED}$  and thus LED brightness:

$$I_{LED} \approx 10 \left( \frac{1.25V}{R_A} + \frac{V_{FS}}{R_{DIVIDER}} \right)$$

**Note 2:**  $R_B$  determines full-scale voltage:

$$V_{FS} \approx 1.25 \left( 1 + \frac{R_B}{R_A} \right) + I_{REF} R_B, \text{ where } I_{REF} \text{ is nominally } 80 \mu A.$$

**Note 3:**  $V^+$  may be 3V to 20V, additionally, for proper operation  $V^+ \geq V_{LED}$ ,  $\geq V_{SIG} + 1.5V$ ,  $\geq V_{REF} + 1.5V$ .

**Note 4:** Mode controls type of display. Connect to LED 9 for dot display and to  $V^+$  for bar display.

**Note 5:**  $V_{LED}$  may be 3V–20V (see Note 3).  $V_{LED}$  may be limited by the driver circuit dissipation rating.

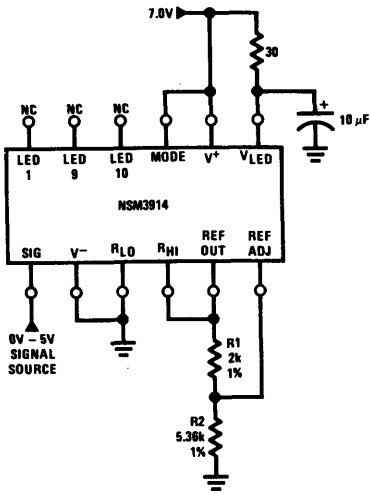
## Recommended Display Processing

The NSM3914, NSM3915, NSM3916 are constructed on a standard printed circuit board substrate and covered with a plastic lens. The edge connector tab will stand 230°C for 5 seconds. Permanent damage to the display will result if lens temperature exceeds 70°C. Since the display is not hermetic, immersion of the entire package during flux and clean operation may cause condensation of flux or cleaner on the underside of the lens. Only the edge connectors should be immersed.

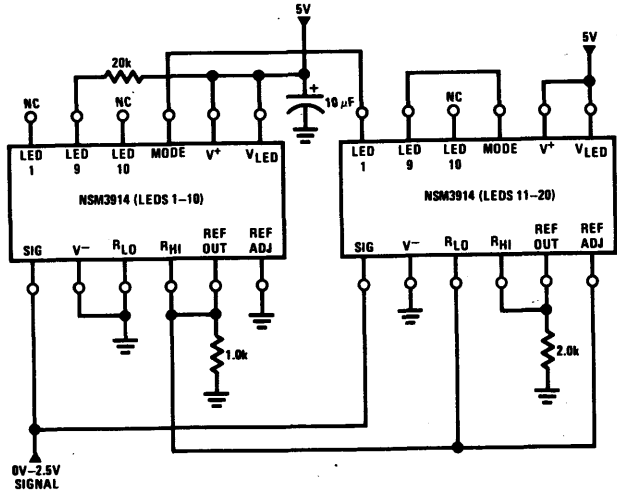
Rosin core solder, solid core solder, and low activity organic fluxes are recommended. Freon TF, Isopropanol, Methanol or Ethanol solvents are recommended only at room temperature and for short periods. The use of other solvents or elevated temperature use of the recommended solvents may cause permanent damage to the lens or display.

## Typical Applications

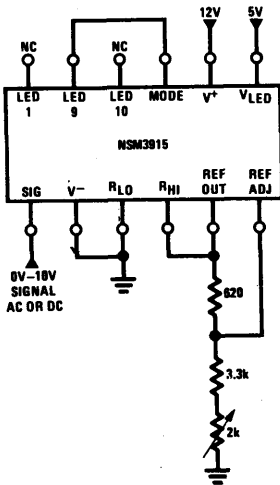
**Linear Bar Graph (5V Full-Scale)**



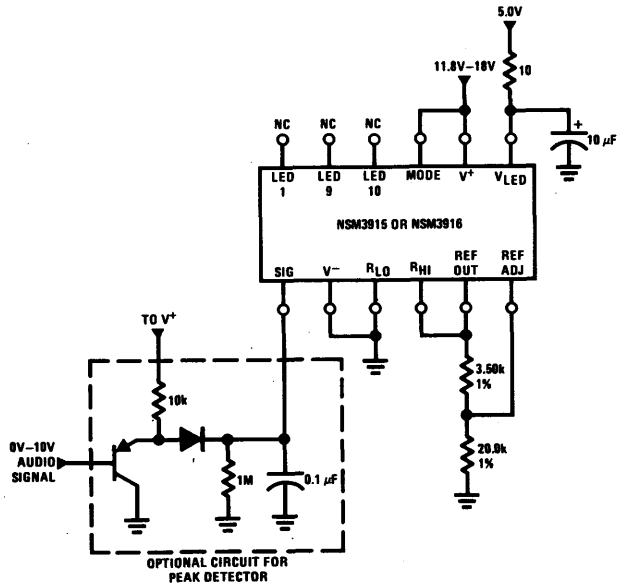
**20-Segment Linear Dot Graph (2.5V Full-Scale)**



**Logarithmic Audio Dot Graph (10V Full-Scale)**



**Logarithmic (NSM3915) or VU (NSM3916) Audio Bar Graph**



## NSM4000A LED Display with Driver

### General Description

The NSM4000A is a 4-digit 0.3" height LED display with a serial data-in/parallel data-out LED driver designed to operate with minimal interface to the data source. Current drive to the LEDs is programmable by setting a reference current to a single pin.

- Enable
- TTL compatible
- Wide power supply operation
- Direct current drive (non-multiplexed)

### Features

- Four 0.3" digits with right-hand decimal points
- Outputs available for two external LEDs
- LED current is programmable
- Serial data input

### Applications

- COPs or microprocessor display
- Digital clock, thermometer, counter, voltmeter
- Instrumentation readouts

### Block Diagram

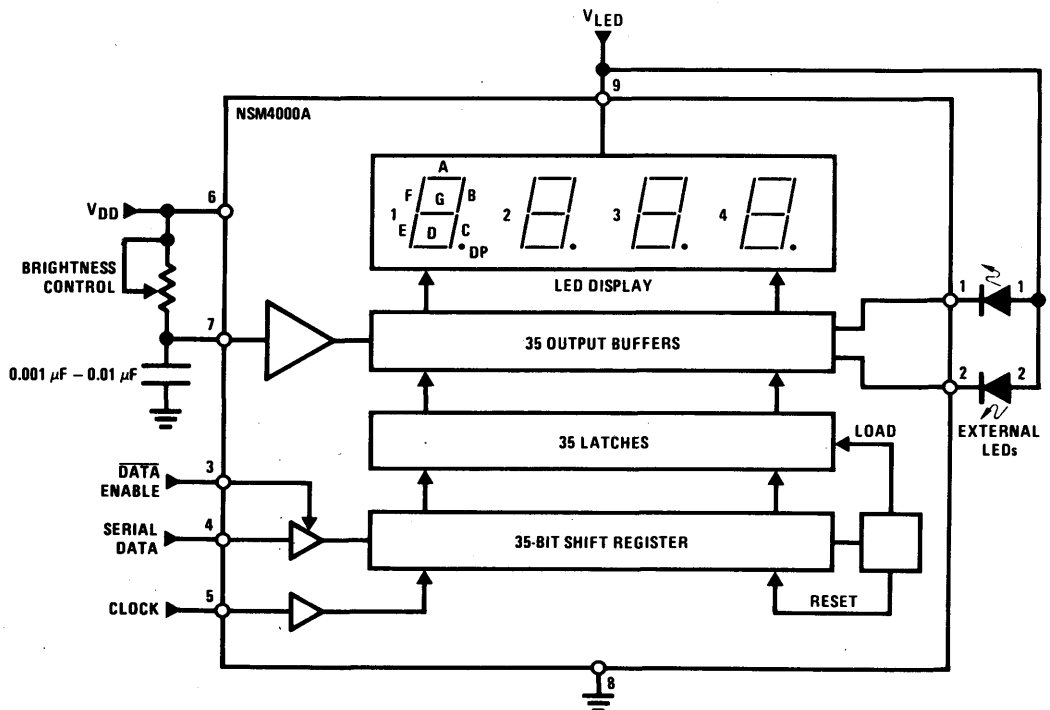


FIGURE 1

## Absolute Maximum Ratings

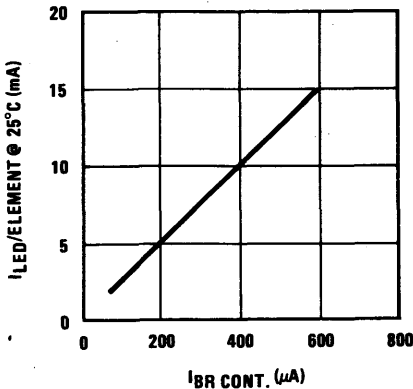
Power Dissipation-Driver (Note 1)	660 mW
Voltage at Any Pin (Figure 1 For $V_{LED}$ )	12V
Operating Temperature	-20 °C to 70 °C
Storage Temperature	-20 °C to 70 °C
Lead Temperature (Soldering, 5 seconds)	230 °C

## Optical and Electrical Characteristics (25 °C, Note 2)

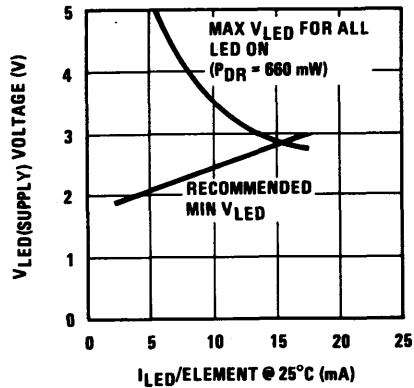
Parameter	Conditions	Min	Typ	Max	Units
LED Segment Intensity	$V_{LED} = 3V, I_{BR.CONT.} = 400 \mu A$	0.10	0.20		mcd
LED Intensity Matching	$V_{LED} = 3V, I_{BR.CONT.} = 400 \mu A$		$\pm 33$		%
LED Current/Segment	$I_{BR.CONT.} = 400 \mu A$		10		mA
Peak Wavelength			660		nm
$V_{DD}$ Supply Current				7	mA
Input Voltages					
Logical "0" Level		-0.3		0.8	V
Logical "1" Level	$4.75V \leq V_{DD} \leq 5.25V$	2.2		$V_{DD}$	V
	$V_{DD} > 5.25V$	$V_{DD} - 2$		$V_{DD}$	V
Brightness Input		0		600	$\mu A$
Input Clock Frequency		0		0.5	MHz
Duty Cycle		40	50	60	%

**Note 1:** Driver dissipation is given by  $P_{DR} = (V_{LED} - 1.7V)I_{LED(Total @ 25^\circ C)} + (V_{DD}) 7mA$  where  $V_{LED}$  is the LED supply voltage, 1.7V is the nominal LED voltage drop, and 7 mA is the maximum current of the  $V_{DD}$  supply.

**Note 2:** Unless otherwise stated, all specifications apply with the following conditions:  $V_{DD}$  (supply) 4.75V to 11V,  $V_{LED}$  (supply) as described in Figure 3, and brightness input 200  $\mu A$  to 600  $\mu A$ .



**FIGURE 2. Typical LED Element Current vs Applied Brightness Control Current**



**FIGURE 3. LED Supply Voltage Range**

## Functional Description

Serial data transfer from the data source to the display driver is accomplished with three signals: data input, data enable, and clock. The data format consists of a leading "1" followed by 35 data bits. This allows data transfer without an additional load signal. The 35 data bits are latched after the 36th bit is complete, thus providing non-multiplexed direct drive to the display. Outputs change only if the serial data bits differ from the previous time.

A block diagram is shown in Figure 1, and Figures 4 and 5 show the timing relationships and input data format. The start bit precedes the 35 data bits. At the 36th clock, a LOAD signal is generated synchronously with the high state of the clock, which loads the 35 bits in the shift registers into the latches. At the low state of the clock, a RESET signal is generated which clears all the shift registers for the next set of data. The shift registers are static master-slave configuration. There is no clear for

the master portion of the first shift register, thus allowing continuous operation.

If the clock is not continuous, there must be a complete set of 36 clocks, otherwise the shift registers will not clear.

When the chips first powers ON, an internal power ON reset signal is generated which resets all registers and all latches. The START bit and the first clock return the chip to its normal operation.

Bit 1 is the first bit following the start bit and determines the drive current state of segment A of digit 1 (note: seg-

ment and digit designations are given in the block diagram of *Figure 1*). The bit sequence for all segments is shown in *Table I*.

The LED element current is typically 25 times greater than the current into the brightness control pin as shown in *Figure 2*. Relationship of the LED current to LED supply voltage is shown in *Figure 3*.

A capacitor should be connected from the brightness control pin to the ground pin to prevent oscillations.

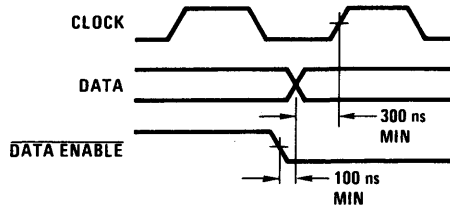


FIGURE 4. Timing Relationships

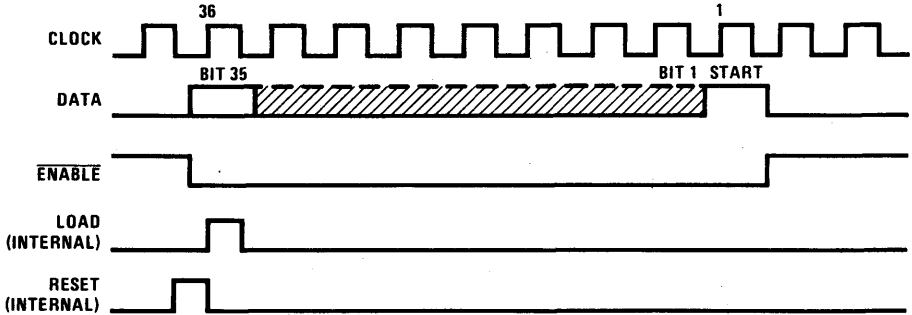


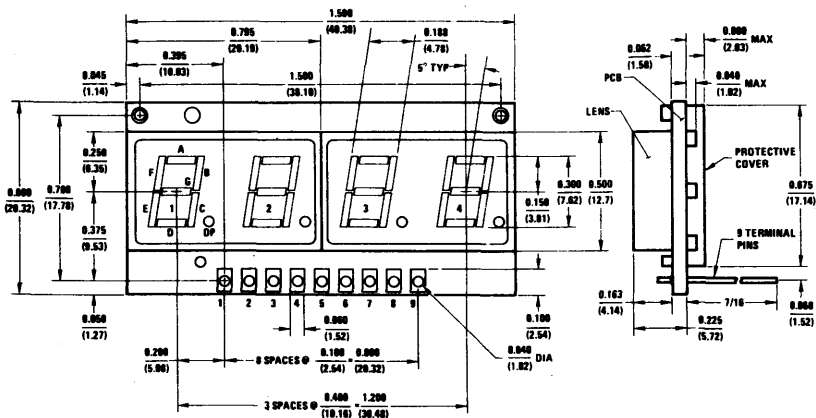
FIGURE 5. Input Data Format

TABLE I. SERIAL INPUT SEQUENCE

Bit #	Digit #	Segment	Bit #	Digit #	Segment
1	1	A	18	3	B
2	1	B	19	3	C
3	1	C	20	3	D
4	1	D	21	3	E
5	1	E	22	3	F
6	1	F	23	3	G
7	1	G	24	3	DP
8	1	DP	25	4	A
9	2	A	26	4	B
10	2	B	27	4	C
11	2	C	28	4	D
12	2	D	29	4	E
13	2	E	30	4	F
14	2	F	31	4	G
15	2	G	32	4	DP
16	2	DP	33	—	LED 1
17	3	A	34	—	LED 2



**Physical Dimensions and Pin Connections** inches (millimeters)

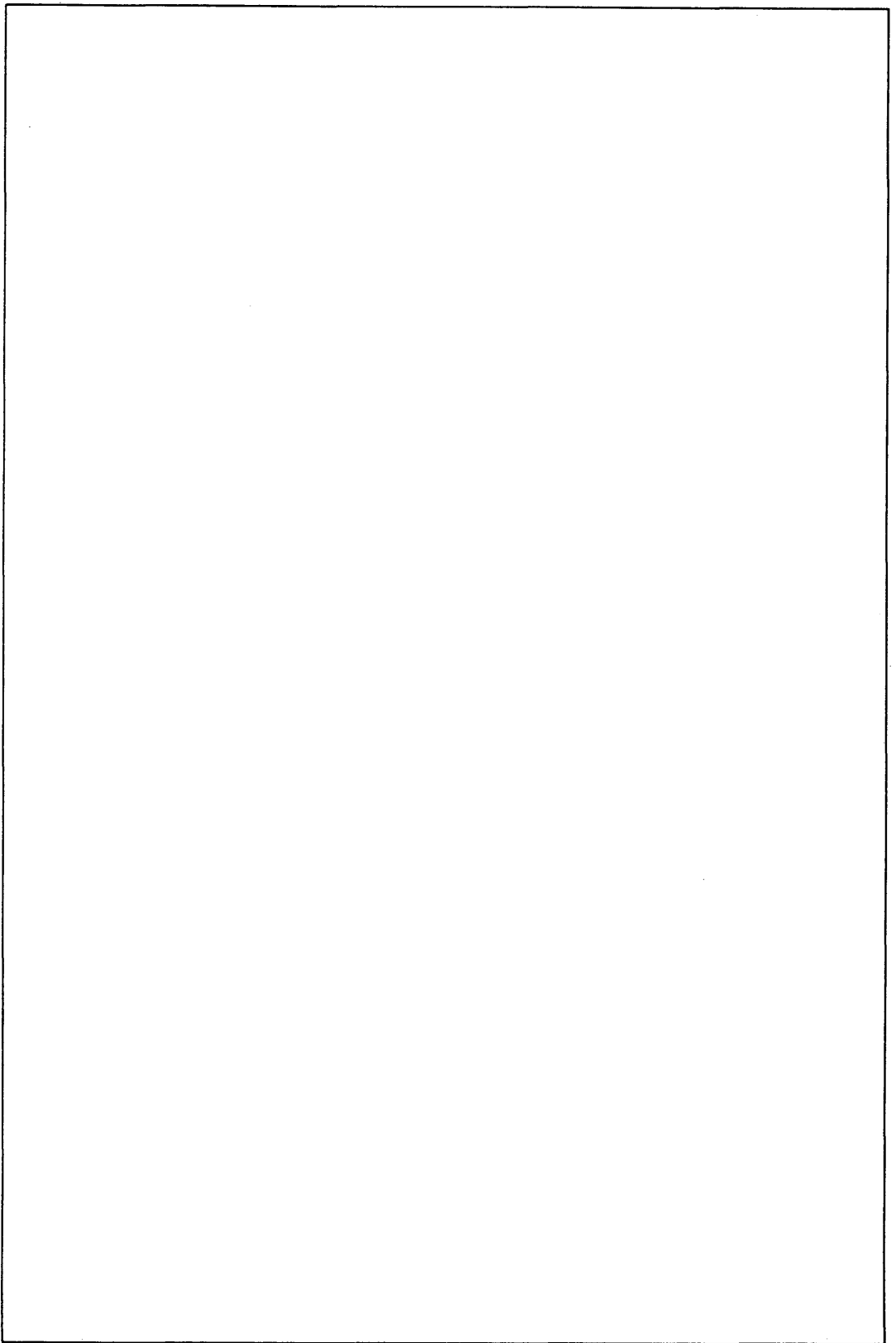


Pin	Electrical Connection
1	External LED 1
2	External LED 2
3	Enable In
4	Data In
5	Clock In
6	V <sub>DD</sub>
7	Brightness Control
8	Gnd
9	V <sub>LED</sub>

**Recommended Display Processing**

The NSM4000A is constructed on a standard printed circuit board substrate and covered with a plastic lens. The edge connector tab will stand 230°C for 5 seconds. Permanent damage to the display will result if lens temperature exceeds 70°C. Since the display is not hermetic, immersion of the entire package during flux and clean operation may cause condensation of flux or cleaner on the underside of the lens. Only the edge connectors should be immersed.

Rosin core solder, solid core solder, and low activity organic fluxes are recommended. Freon TF, Isopropanol, Methanol or Ethanol solvents are recommended only at room temperature and for short periods. The use of other solvents or elevated temperature use of the recommended solvents may cause permanent damage to the lens or display.





## User Guide—Array Drivers

# Digits	TTL Drivers		MOS Drivers	
	Segment	Digit	Segment	Digit
2	DS8669			
3	DS8858 (Note 1)	DS8859 (Note 2)	DS8867 or two DS75493 (Note 1)	DS8877 (Note 5)
6	DS8858 (Note 1)	same	DS8867 or two DS75493 (Note 1)	same
8	DS8858 (Note 1)	two of same	DS8867 or two DS75493 (Note 1)	DS8871 (Note 3)
9	DS8858 (Note 1)	two of same	DS8867 or two DS75493 (Note 1)	DS8872/3 (Note 4)
12	DS8858 (Note 1)	two of same	DS8867 or two DS75493 (Note 1)	DS8865
14	DS8858 (Note 1)	three of same	DS8867 or two DS75493 (Note 1)	DS8865

**Note 1:** DS8858 is a 7-segment driver, DS8667 drives 8 segments, and DS75493 drives 4 segments.

**Note 2:** DS8859 (non-inverting) and DS8669 (inverting) have hex latches which may be disabled by permanently keeping STROBE low.

**Note 3:** DS8863 may also be used.

**Note 4:** DS8873 has a low-battery indicator. DS8973, 4, 5, 6 and 8 are special 9-digit drivers for battery operation.

**Note 5:** The DS8877 (5-50 mA) may be replaced by DS8892 (200 mA) or DS75492 (250 mA). Also, the DS75491 (quad) can source or sink up to 50 mA, and can therefore be used as either a digit driver or segment driver (the latter undecoded, however).

## User Guide—Display Drivers

### SEGMENT DRIVERS—DIRECT OR STROBED

#### Common Cathode

DS8858 (TTL)

MM74C48 or CD4511 (CMOS)

To interface PMOS to CMOS or TTL, use buffers (inverting and non-inverting) MM74C901-904.

Use external transistors for heavier drive requirements.

#### Common Anode

DM7446A (TTL)

DM7447A (TTL)

Above comments concerning buffers and external transistors apply.

**Note:** These are all decoded segment drivers. For non-decoded applications, See 1978 Interface Databook.

### DIGIT DRIVERS

External NPN (common cathode) or PNP (common anode) transistors of proper  $V_{CE(sat)}$ , breakdown, and current capability may be used. PNP core-driver array DH3467C (4 per package) and DS8692 (8 NPN's per package), rated at 1A and 0.5A (respectively) each transistor, may be economical. A variety of suitable common cathode digit drivers is listed in the 1978 Interface Databook.



## ADD3501 3½ Digit DVM with Multiplexed 7-Segment Output

### General Description

The ADD3501 (MM74C935-1) monolithic DVM circuit is manufactured using standard complementary MOS (CMOS) technology. A pulse modulation analog-to-digital conversion technique is used and requires no external precision components. In addition, this technique allows the use of a reference voltage that is the same polarity as the input voltage.

One 5V (TTL) power supply is required. Operating with an isolated supply allows the conversion of positive as well as negative voltages. The sign of the input voltage is automatically determined and output on the sign pin. If the power supply is not isolated, only one polarity of voltage may be converted.

The conversion rate is set by an internal oscillator. The frequency of the oscillator can be set by an external RC network or the oscillator can be driven from an external frequency source. When using the external RC network, a square wave output is available. It is important to note that great care has been taken to synchronize digit multiplexing with the A/D conversion timing to eliminate noise due to power supply transients.

The ADD3501 has been designed to drive 7-segment multiplexed LED displays directly with the aid of external digit buffers and segment resistors. Under condition of overrange, the overflow output will go high and the display will read +OFL or -OFL, depending on whether the input voltage is positive or negative. In addition to this, the most significant digit is blanked when zero.

A start conversion input and a conversion complete output are included on all 4 versions of this product.

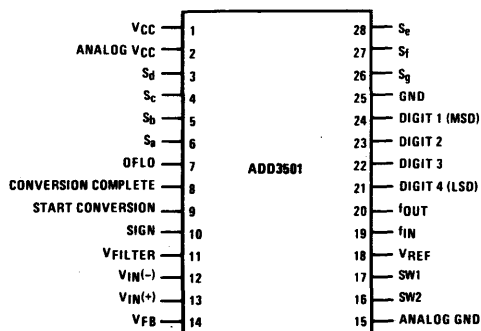
### Features

- Operates from single 5V supply
- Converts 0V to  $\pm 1.999V$
- Multiplexed 7-segment
- Drives segments directly
- No external precision component necessary
- Accuracy specified over temperature
- Medium speed – 200ms/conversion
- Internal clock set with RC network or driven externally
- Overrange indicated by +OFL or -OFL display reading and OFLO output
- Analog inputs in applications shown can withstand  $\pm 200$  Volts

### Applications

- Low cost digital power supply readouts
- Low cost digital multimeters
- Low cost digital panel meters
- Eliminate analog multiplexing by using remote A/D converters
- Convert analog transducers (temperature, pressure, displacement, etc.) to digital transducers

### Connection Diagram



## ADD3701 3<sup>3</sup>/<sub>4</sub> Digit DVM with Multiplexed 7-Segment Output

### General Description

The ADD3701 (MM74C936-1) monolithic DVM circuit is manufactured using standard complementary MOS (CMOS) technology. A pulse modulation analog-to-digital conversion technique is used and requires no external precision components. In addition, this technique allows the use of a reference voltage that is the same polarity as the input voltage.

One 5V (TTL) power supply is required. Operating with an isolated supply allows the conversion of positive as well as negative voltages. The sign of the input voltage is automatically determined and output on the sign pin. If the power supply is not isolated, only one polarity of voltage may be converted.

The conversion rate is set by an internal oscillator. The frequency of the oscillator can be set by an external RC network or the oscillator can be driven from an external frequency source. When using the external RC network, a square wave output is available. It is important to note that great care has been taken to synchronize digit multiplexing with the A/D conversion timing to eliminate noise due to power supply transients.

The ADD3701 has been designed to drive 7-segment multiplexed LED displays directly with the aid of external digit buffers and segment resistors. Under condition of overrange, the overflow output will go high and the display will read +OFL or -OFL, depending on whether the input voltage is positive or negative. In addition to this, the most significant digit is blanked when zero.

A start conversion input and a conversion complete output are included.

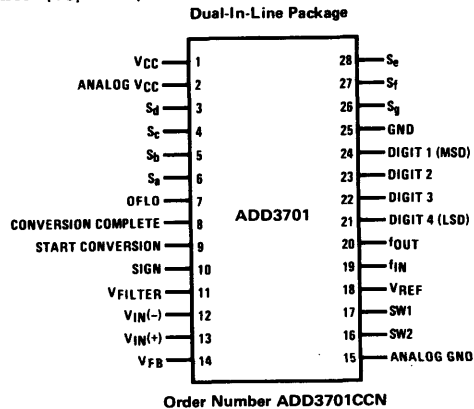
### Features

- Operates from single 5V supply
- Converts 0 to  $\pm 3999$  counts
- Multiplexed 7-segment
- Drives segments directly
- No external precision components necessary
- Accuracy specified over temperature
- Medium speed – 400ms/conversion
- Internal clock set with RC network or driven externally
- Overrange indicated by +OFL or -OFL display reading and OFLO output
- Analog inputs in applications shown can withstand  $\pm 200$  Volts

### Applications

- Low cost digital power supply readouts
- Low cost digital multimeters
- Low cost digital panel meters
- Eliminate analog multiplexing by using remote A/D converters
- Convert analog transducers (temperature, pressure, displacement, etc.) to digital transducers
- Indicators and displays requiring readout up to 3999 counts

### Connection Diagram (Top View)





# CD4511BM/CD4511BC BCD-to-7 Segment Latch/Decoder/Driver

## General Description

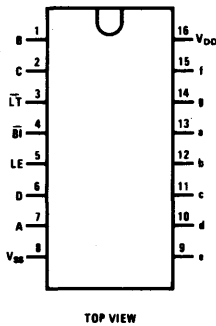
The CD4511BM/CD4511BC BCD-to-seven segment latch/decoder/driver is constructed with complementary MOS (CMOS) enhancement mode devices and NPN bipolar output drivers in a single monolithic structure. The circuit provides the functions of a 4-bit storage latch, an 8421 BCD-to-seven segment decoder, and an output drive capability. Lamp test (LT), blanking (BI), and latch enable (LE) inputs are used to test the display, to turn-off or pulse modulate the brightness of the display, and to store a BCD code, respectively. It can be used with seven-segment light emitting diodes (LED), incandescent, fluorescent, gas discharge, or liquid crystal readouts either directly or indirectly.

Applications include instrument (e.g., counter, DVM, etc.) display driver, computer/calculator display driver, cockpit display driver, and various clock, watch, and timer uses.

## Features

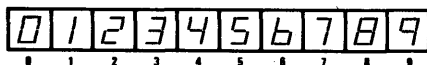
- Low logic circuit power dissipation
- High current sourcing outputs (up to 25 mA)
- Latch storage of code
- Blanking input
- Lamp test provision
- Readout blanking on all illegal input combinations
- Lamp intensity modulation capability
- Time share (multiplexing) facility
- Equivalent to Motorola MC14511

## Connection Diagram



TOP VIEW

Display



Segment Identification



## Truth Tables

INPUTS						OUTPUTS								
LE	BI	LT	D	C	B	A	a	b	c	d	e	f	g	DISPLAY
X	X	0	X	X	X	X	1	1	1	1	1	1	1	8
X	0	1	X	X	X	X	0	0	0	0	0	0	0	
0	1	1	0	0	0	0	1	1	1	1	1	1	0	0
0	1	1	0	0	0	1	0	1	1	0	0	0	0	1
0	1	1	0	0	1	0	1	1	0	1	1	0	1	2
0	1	1	0	0	1	1	1	1	1	1	0	0	1	3
0	1	1	0	1	0	0	0	1	1	0	0	1	1	4
0	1	1	0	1	0	1	1	0	1	1	0	1	1	5
0	1	1	0	1	1	0	0	0	1	1	1	1	1	6
0	1	1	0	1	1	1	1	1	1	0	0	0	0	7
0	1	1	1	0	0	0	1	1	1	1	1	1	1	8
0	1	1	1	0	0	1	1	1	1	0	0	1	1	9
0	1	1	1	0	1	0	0	0	0	0	0	0	0	
0	1	1	1	0	1	1	0	0	0	0	0	0	0	
0	1	1	1	1	0	1	0	0	0	0	0	0	0	
0	1	1	1	1	1	0	0	0	0	0	0	0	0	
0	1	1	1	1	1	1	0	0	0	0	0	0	0	
1	1	1	X	X	X	X								.

X = Don't care

\*Depends upon the BCD code applied during the 0 to 1 transition of LE.

# DM54/DM7446A, 47A, LS47, 48, LS48, LS49 BCD/7-Segment Decoders/Drivers

## General Description

The 46A, 47A and LS47 feature active-low outputs designed for driving common-anode LED's or incandescent indicators directly; and the 48, LS48 and LS49 feature active-high outputs for driving lamp buffers or common-cathode LED's. All of the circuits except the LS49 have full ripple-blanking input/output controls and a lamp test input. The LS49 features a direct blanking input. Segment identification and resultant displays are shown on a following page. Display patterns for BCD input counts above nine are unique symbols to authenticate input conditions.

All of the circuits except the LS49 incorporate automatic leading and/or trailing-edge, zero-blanking control (RBI and RBO). Lamp test (LT) of these devices may be performed at any time when the BI/RBO node is at a high logic level. All types (including LS49) contain an overriding blanking input (BI) which can be used to control the lamp intensity (by pulsing), or to inhibit the outputs.

## Features

- All circuit types feature lamp intensity modulation capability

### 5446A/7446A, 5447A/7447A, 54LS47/74LS47

- Open-collector outputs drive indicators directly
- Lamp-test provision
- Leading/trailing zero suppression

### 5448/7448, 54LS48/74LS48

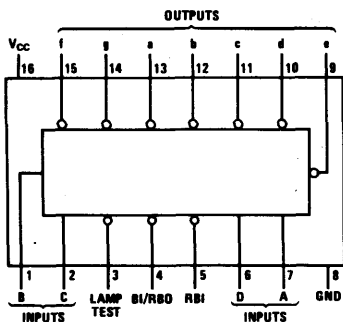
- Internal pull-ups eliminate need for external resistors
- Lamp-test provision
- Leading/trailing zero suppression

### 54LS49/74LS49

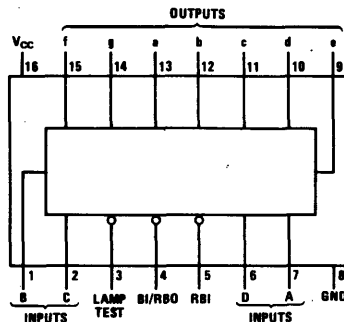
- Open-collector outputs
- Blanking input

TYPE	DRIVER OUTPUTS				TYPICAL POWER DISSIPATION	PACKAGES
	ACTIVE LEVEL	OUTPUT CONFIGURATION	SINK CURRENT	MAX VOLTAGE		
DM5446A	low	open-collector	40 mA	30V	320 mW	J, N, W
DM5447A	low	open-collector	40 mA	15V	320 mW	J, N, W
DM5448	high	2-k $\Omega$ pull-up	6.4 mA	5.5V	265 mW	J, N, W
DM54LS47	low	open-collector	12 mA	15V	35 mW	J, N, W
DM54LS48	high	2 k $\Omega$ pull-up	2 mA	5.5V	125 mW	J, N, W
DM54LS49	high	open-collector	4 mA	5.5V	40 mW	J, N, W
DM7446A	low	open-collector	40 mA	30V	320 mW	J, N, W
DM7447A	low	open-collector	40 mA	15V	320 mW	J, N, W
DM7448	high	2-k $\Omega$ pull-up	6.4 mA	5.5V	265 mW	J, N, W
DM74LS47	low	open-collector	24 mA	15V	35 mW	J, N, W
DM74LS48	high	2 k $\Omega$ pull-up	6 mA	5.5V	125 mW	J, N, W
DM74LS49	high	open-collector	8 mA	5.5V	40 mW	J, N, W

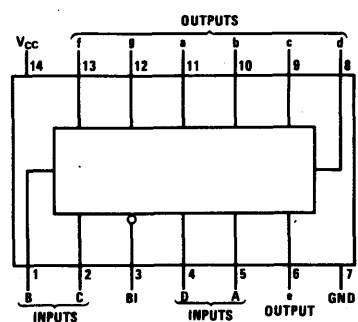
## Connection Diagrams



5446A/7446A(J), (N), (W);  
5447A/7447A(J), (N), (W);  
54LS47/74LS47(J), (N), (W)



5448/7448(J), (N), (W);  
54LS48/74LS48(J), (N), (W)



54LS49/74LS49(J), (N), (W)



## DS75491 MOS-to-LED Quad Segment Driver DS75492 MOS-to-LED Hex Digit Driver

### General Description

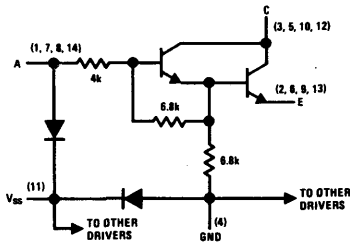
The DS75491 and DS75492 are interface circuits designed to be used in conjunction with MOS integrated circuits and common-cathode LED's in serially addressed multi-digit displays. The number of drivers required for this time-multiplexed system is minimized as a result of the segment-address-and-digit-scan method of LED drive.

### Features

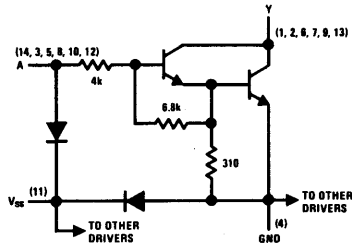
- 50 mA source or sink capability per driver (DS75491)
- 250 mA sink capability per driver (DS75492)
- MOS compatibility (low input current)
- Low standby power
- High-gain Darlington circuits

### Schematic and Connection Diagrams

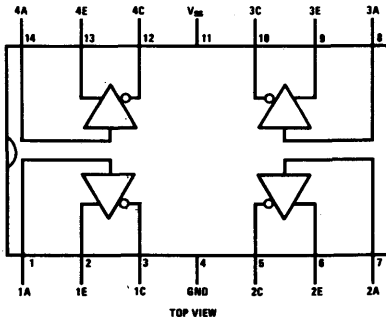
DS75491 (each driver)



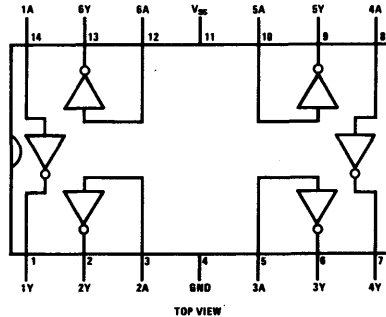
DS75492 (each driver)



DS75491 Dual-In-Line Package



DS75492 Dual-In-Line Package



Order Number DS75491N  
or DS75492N



# DS55493/DS75493 Quad LED Segment Driver

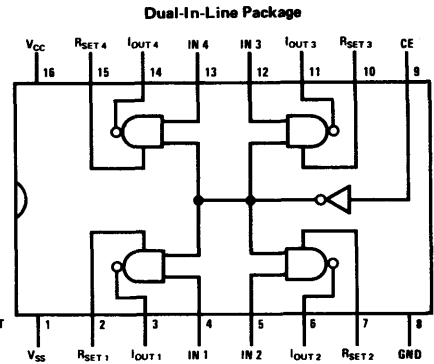
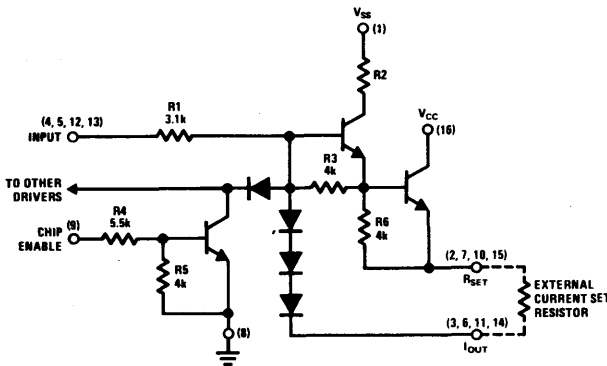
## General Description

The DS55493/DS75493 is a quad LED segment driver. It is designed to interface between MOS IC's and LED's. An external resistor is required for each segment to drive the output current which is approximately equal to  $0.7V/R_L$  and is relatively constant, independent of supply variations. Blanking can be achieved by taking the chip enable (CE) to a logical "1" level.

## Features

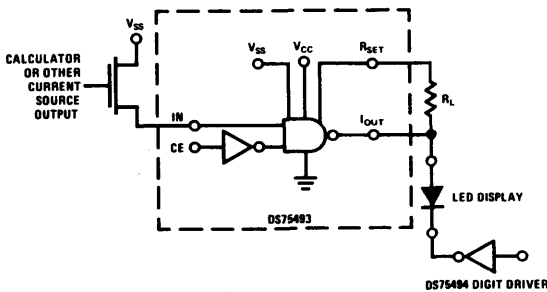
- Low voltage operation
- Low input current for MOS compatibility
- Low standby power
- Display blanking capability
- Output current regulation
- Quad high gain circuits

## Schematic and Connection Diagrams



Order Number DS55493J, DS75493J  
or DS75493N

## Typical Application



## Truth Table

CE	V <sub>IN</sub>	I <sub>OUT</sub>
0	1	ON
0	0	OFF
1	X	OFF

X = Don't care

## DS8669 2-Digit BCD-to-7-Segment Decoder/Driver

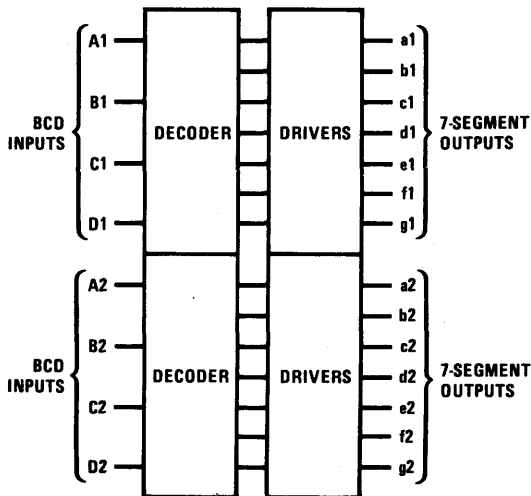
### General Description

The DS8669 is a 2-digit BCD to 7-segment decoder/driver for use with common anode LED displays. The DS8669 drives 2 7-segment LED displays without multiplexing. Outputs are open-collector, and capable of sinking 25 mA/segment. Applications consist of TV and CB channel displays.

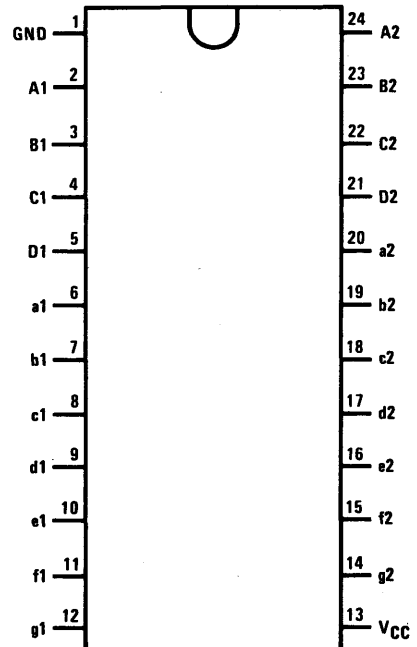
### Features

- Direct 7-segment drive
- 25 mA/segment current sink capability
- Low power requirement—16 mA typ
- Very low input currents—2  $\mu$ A typ
- Input clamp diodes to both  $V_{CC}$  and ground
- No multiplexing oscillator noise

### Logic and Connection Diagrams



Dual-In-Line Package



TOP VIEW

Order Number DS8669N

# DS8692, DS8693, DS8694 Printing Calculator Interface Set

## General Description

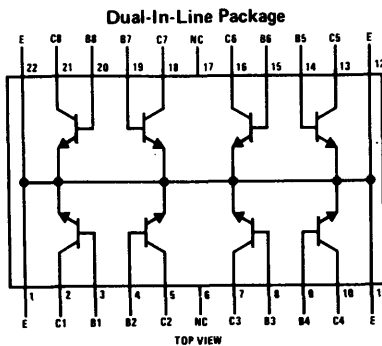
Two DS8692 IC's and one each of the DS8693 and DS8694 provide the complete interface necessary between the MM5787 calculator chip and the Seiko Model 310 printing head. The DS8692 is an array of eight common emitter output transistors each capable of sinking 350 mA, with open collector saturating outputs. The DS8693 contains the interface logic for the color solenoid driver, motor driver, and 7-column character select solenoid drivers. The DS8694 contains the interface logic for 8-column solenoid drivers plus the clock oscillator and timing signal buffer. The color and character select solenoid latch outputs of both are

constant current outputs supplying the base current for the DS8692 arrays. These outputs also feature active pull-down. The motor drive latch output is an open collector capable of sinking 20 mA.

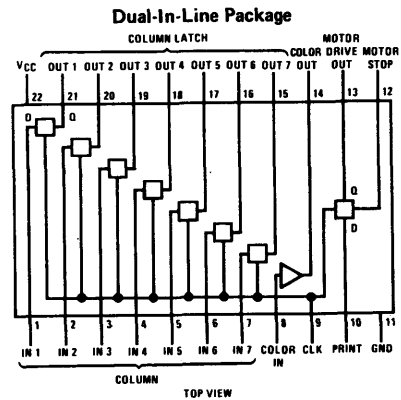
## Features

- Provides complete interface package for printing calculators with minimum number of packages and minimum number of external components
- 350 mA sink capability

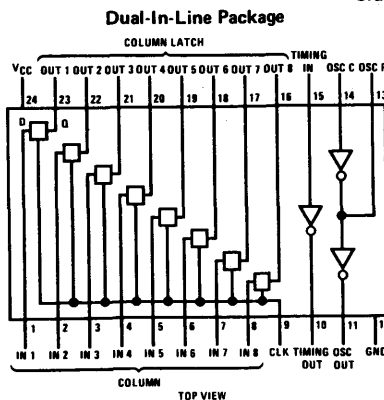
## Connection Diagrams



Order Number DS8692N



Order Number DS8693N



Order Number DS8694N



## DS7856/DS8856, DS8857, DS7858/DS8858 BCD-to-7-Segment LED Drivers

### General Description

This series of 7-segment display drivers fulfills a wide variety of requirements for most active high (common cathode) Light Emitting Diodes (LEDs). Each device fully decodes a 4-bit BCD input into a number from 0 through 9 in the standard 7-segment display format, and BCD numbers above 9 into unique patterns that verify operation. All circuits operate off of a single 5.0V supply.

The DS7856/DS8856 has active-high, passive pull-up outputs which provide a typical source current of 6.0 mA at an output voltage of 1.7V. The applications are the same as for the DM5448/DM7448 except that more design freedom is allowed with higher source current levels. This circuit was designed to drive the MAN-4 or equivalent type display directly without the use of external current limit resistors, and replaces the MSD101.

The DS8857 has active-high outputs and is designed to be used with common cathode LED's in the multiplex mode. It provides a typical source current of 50 mA at an output voltage of 2.3V.

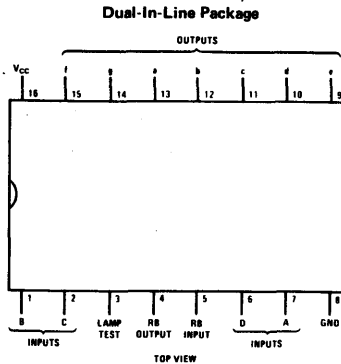
In addition, with the use of an external current limit resistor per segment, this circuit can be used in higher current non-multiplex LED applications. It replaces the MSD102.

The DS7858/DS8858 has active high outputs with source current adjustable with the use of external current limit resistors, one per segment. This feature allows extreme flexibility in source current value selection for either multiplex or non-multiplex common cathode LED drive applications. It allows the system designer freedom to tailor the drive current for his particular applications.

### Features

- Lamp-test input
- Leading/trailing zero suppression (RBI and RBO)
- Blanking input that may be used to modulate lamp intensity or inhibit output
- TTL and DTL compatible
- Input clamping diodes

### Connection Diagram



Order Number DS7856J, DS8856J,  
DS8857J, DS7858J, DS8858J

Order Number DS8856N  
or DS8858N

Order Number DS7856W  
or DS7858W

### Output Display



## DS8859, DS8869 Open Collector Hex Latch LED Drivers

### General Description

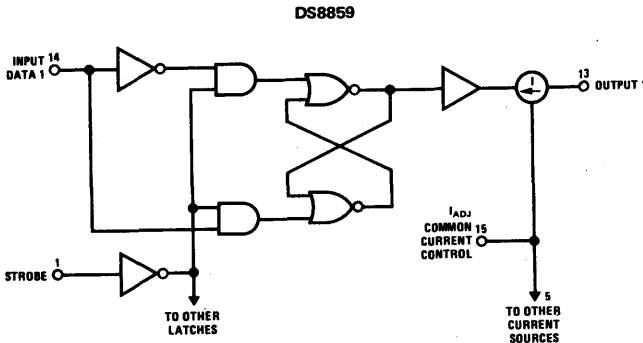
The DS8859, DS8869 are TTL compatible open collector hex latch LED drivers with programmable current sink outputs. The current sinks are nominally set at 20 mA but may be adjusted by external resistors for any value between 0–40 mA. Each device contains six latches which may be set by input data terminals. An active low strobe common to all six latches enables the data input terminals. The DS8859 current sink outputs are switched on by entering a high level into the latches and the DS8869 current sink outputs are switched on by entering a low level into the latches.

The devices are available in either a molded or cavity package. In order not to damage the devices there is a limit placed on the power dissipation allowable for each package type. This information is shown in the graph included in this data sheet.

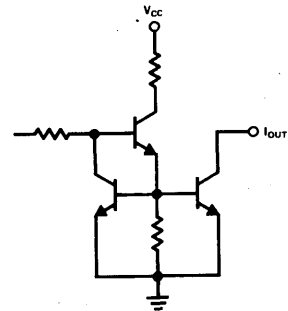
### Features

- Built-in latch
- Programmable output current
- TTL compatible inputs
- 40 mA output sink

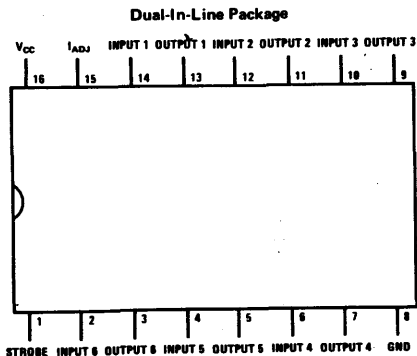
### Logic Diagram



### Output Circuit



### Connection Diagram



### Truth Table

COMMON STROBE	INPUT DATA	DS8859 OUTPUT (t + 1)	DS8869 OUTPUT (t + 1)
0	0	OFF	ON
0	1	ON	OFF
1	X	OUTPUT (t)	OUTPUT (t)

TOP VIEW  
Order Number DS8859J, DS8869J  
or DS8859N, DS8869N





# DS8867 8-Segment Constant Current Driver

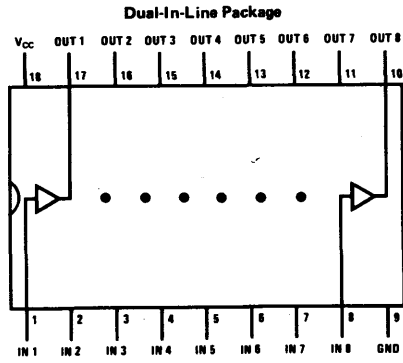
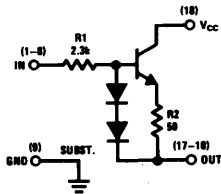
## General Description

The DS8867 is an 8-segment driver designed to be driven from MOS circuits operating at 8V ±10% minimum V<sub>SS</sub> supply and will supply 14 mA typically to an LED display. The output current is insensitive to V<sub>CC</sub> variations.

## Features

- Internal current control—no external resistors
- 100% efficient, no standby power
- Operates in three and four cell battery systems
- Inputs and outputs grouped for easy PC layout

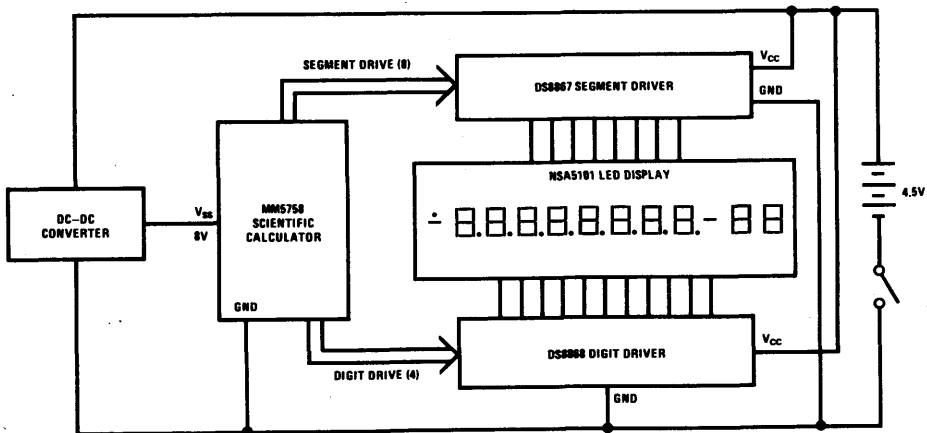
## Schematic and Connection Diagrams



Order Number DS8667N

## Typical Application

Typical 3 Cell Scientific Calculator Circuit





# National Semiconductor

## DS8871, DS8872, DS8873, DS8920, DS8977

### Saturating LED Cathode Drivers

#### General Description

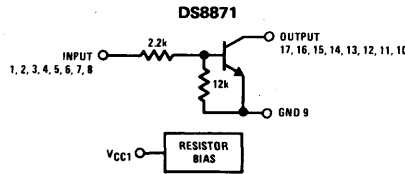
The DS8871, DS8872, DS8873, DS8920 and DS8977 are bipolar integrated circuits designed to interface between MOS calculator circuits and common cathode LED displays operating in the multiplexed mode with a digit current of up to 40 mA. The DS8871 is an 8-digit driver; the DS8920 and the DS8872 are 9-digit drivers; and the DS8873 is a 9-digit driver with a built-in battery condition indicator that turns on the digit 9 decimal point when the battery voltage drops to 6.5V (typical). The DS8977 is a 7-digit version of the DS8873. In a typical calculator system operating on a 9V battery, the low battery indicator comes on as a warning that

the battery should be replaced. But the calculator (MM5737 or equivalent) will still function properly for awhile. The DS8920 is identical to the DS8872 in a 20-pin package.

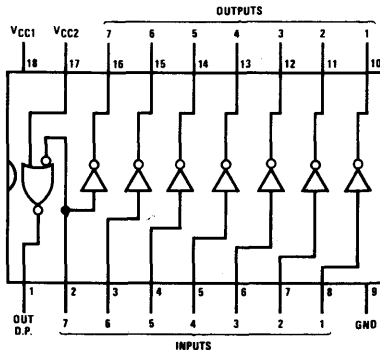
#### Features

- Single saturating transistor output
- Low battery indicator
- MOS compatible inputs
- Inputs and outputs clustered for easy wiring
- Drivers consume no standby power

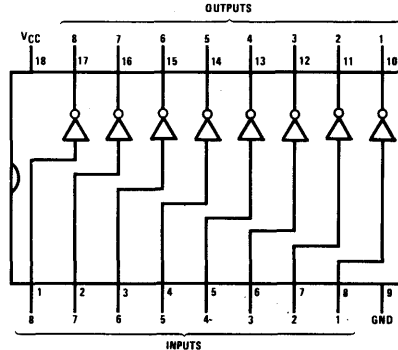
#### Schematic Diagram



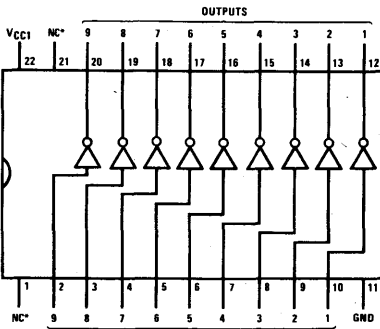
#### Connection Diagrams (Dual-In-Line Packages, Top Views)



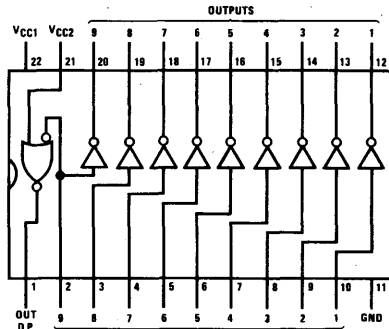
Order Number DS8977N



Order Number DS8871N



Order Number DS8872N



Order Number DS8873N



## DS8877 6-Digit LED Driver

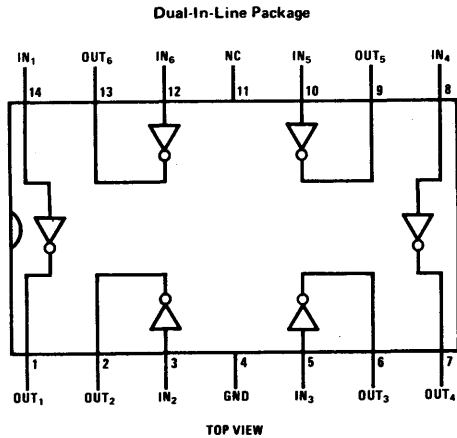
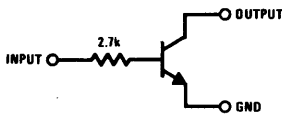
### General Description

The DS8877 is a 6-digit LED driver designed as a pin-for-pin replacement for the DS75492 in applications where digit current is in the 5 to 50 mA range. Since the outputs saturate to less than 0.6V, the DS8877 will work on lower battery voltages than most digit drivers. The DS8877 draws *no* standby power.

### Features

- No standby power
- No supply connection
- Operates in 4.5V, 6V or 9V systems
- Pin-for-pin replacement for DS75492 in low current applications

### Logic and Connection Diagrams



Order Number DS8877N



# DS8973, DS8974, DS8975, DS8976, DS8978

## 9-Digit LED Drivers

### General Description

The DS8973, DS8974 and DS8976 are 9-digit drivers designed to operate from 3-cell (DS8973) or 4-cell (DS8974) or 6-cell (DS8976) battery supplies. Each driver will sink 100 mA to less than 0.7V when driven by only 0.1 mA. Each input is blocked by diodes so that the input can be driven below ground with virtually no current drain. This is especially important in calculator systems employing a dc-to-dc converter on the negative side of the battery. If the converter were on the positive side of the battery, the converter would have to handle all of the display current, as well as the MOS calculator chip current. But if it is on the negative side, it only has to handle the MOS current. The DS8973 and DS8974

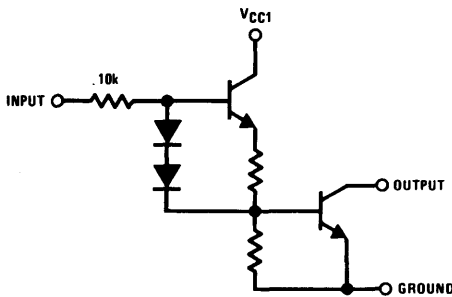
are designed for the more efficient operating mode. The DS8975 is identical to the DS8973, DS8974 and DS8976 but does not specify the low battery indicator. DS8978 is identical to the DS8975 but is in a 20-pin package without low battery pins.

### Features

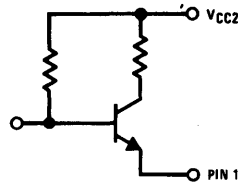
- Nine complete digit drivers
- Built-in low battery indicator
- High current outputs—100 mA
- Choice of 3 or 4-cell operation
- Straight through pin out for easy board layout

### Equivalent Circuit Diagrams

Typical Driver Circuit

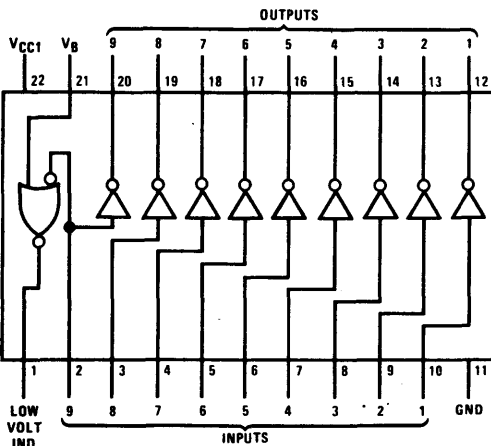


Typical D.P. Out Circuit



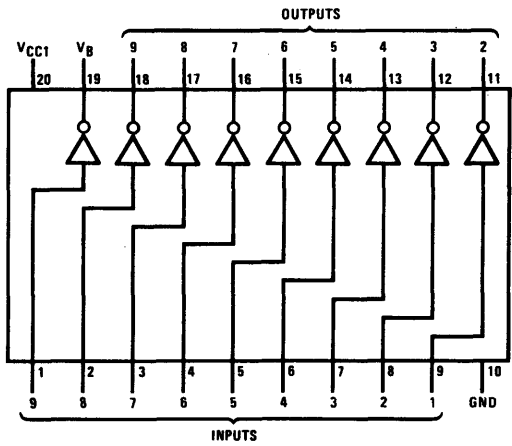
### Connection Diagram

Dual-In-Line Package



TOP VIEW  
Order Number DS8973N, DS8974N,  
DS8975N or DS8976N

Dual-In-Line Package



TOP VIEW  
Order Number DS8978N



# LM3909 LED Flasher/Oscillator

## General Description

The LM3909 is a monolithic oscillator specifically designed to flash Light Emitting Diodes. By using the timing capacitor for voltage boost, it delivers pulses of 2 or more volts to the LED while operating on a supply of 1.5V or less. The circuit is inherently self-starting, and requires addition of only a battery and capacitor to function as a LED flasher.

Packaged in an 8-lead plastic mini-DIP, the LM3909 will operate over the extended consumer temperature range of  $-25^{\circ}\text{C}$  to  $+70^{\circ}\text{C}$ . It has been optimized for low power drain and operation from weak batteries so that continuous operation life exceeds that expected from battery rating.

Application is made simple by inclusion of internal timing resistors and an internal LED current limit resistor. As shown in the first two application circuits, the timing resistors supplied are optimized for nominal flashing rates and minimum power drain at 1.5V and 3V.

Timing capacitors will generally be of the electrolytic type, and a small 3V rated part will be suitable for any LED flasher using a supply up to 6V. However, when picking flash rates, it should be remembered that some electrolytics have very broad capacitance tolerances, for example  $-20\%$  to  $+100\%$ .

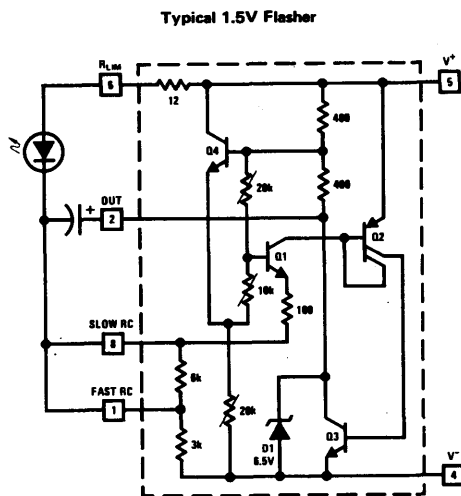
## Features

- Operation over one year from one C size flashlight cell
- Bright, high current LED pulse
- Minimum external parts
- Low cost
- Low voltage operation, from just over 1V to 5V
- Low current drain, averages under 0.5 mA during battery life
- Powerful; as an oscillator directly drives an 8Ω speaker
- Wide temperature range

## Applications

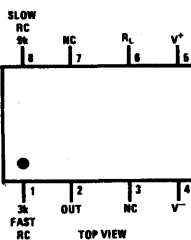
- Finding flashlights in the dark, or locating boat mooring floats
- Sales and advertising gimmicks
- Emergency locators, for instance on fire extinguishers
- Toys and novelties
- Electronic applications such as trigger and sawtooth generators
- Siren for toy fire engine, (combined oscillator, speaker driver)
- Warning indicators powered by 1.4 to 200V

## Schematic Diagram



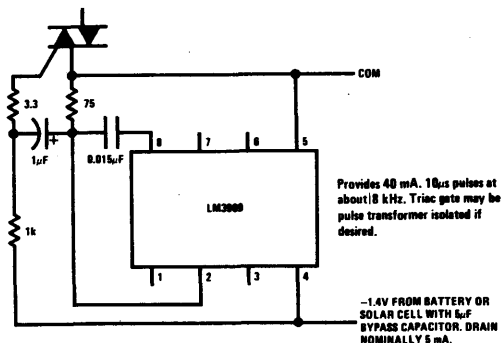
## Connection Diagram

Dual-In-Line Package



## Typical Application

Triac Trigger





## LM3914 Dot/Bar Display Driver

### General Description

The LM3914 is a monolithic integrated circuit that senses analog voltage levels and drives 10 LEDs, providing a linear analog display. A single pin changes the display from a moving dot to a bar graph. Current drive to the LEDs is regulated and programmable, eliminating the need for resistors. This feature is one that allows operation of the whole system from less than 3V.

The circuit contains its own adjustable reference and accurate 10-step voltage divider. The low-bias-current input buffer accepts signals down to ground, or  $V^-$ , yet needs no protection against inputs of 35V above or below ground. The buffer drives 10 individual comparators referenced to the precision divider. Indication non-linearity can thus be held typically to 1/2%, even over a wide temperature range.

Versatility was designed into the LM3914 so that controller, visual alarm, and expanded scale functions are easily added on to the display system. The circuit can drive LEDs of many colors, or low-current incandescent lamps. Many LM3914s can be "chained" to form displays of 20 to over 100 segments. Both ends of the voltage divider are externally available so that 2 drivers can be made into a zero-center meter.

The LM3914 is very easy to apply as an analog meter circuit. A 1.2V full-scale meter requires only 1 resistor and a single 3V to 15V supply in addition to the 10 display LEDs. If the 1 resistor is a pot, it becomes the LED brightness control. The simplified block diagram illustrates this extremely simple external circuitry.

When in the dot mode, there is a small amount of overlap or "fade" (about 1 mV) between segments. This assures that at no time will all LEDs be "OFF", and

thus any ambiguous display is avoided. Various novel displays are possible.

Much of the display flexibility derives from the fact that all outputs are individual, DC regulated currents. Various effects can be achieved by modulating these currents. The individual outputs can drive a transistor as well as a LED at the same time, so controller functions including "staging" control can be performed. The LM3914 can also act as a programmer, or sequencer.

### Features

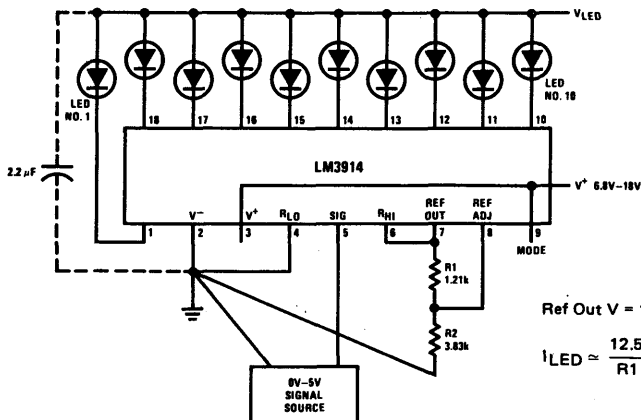
- Bar or dot display mode externally selectable by user
- Expandable to displays of 100 steps
- Internal voltage reference from 1.2V to 12V
- Operates with single supply of less than 3V
- Inputs operate down to ground
- Output current programmable from 2 to 30 mA
- No multiplex switching or interaction between outputs
- Input withstands  $\pm 35V$  without damage or false outputs
- LED driver outputs are current regulated, open-collectors
- Outputs can interface with TTL or CMOS logic
- The internal 10-step divider is floating and can be referenced to a wide range of voltages

The LM3914 is rated for operation from  $0^{\circ}C$  to  $+70^{\circ}C$ . The LM3914N is available in an 18-lead molded (N) package and the LM3914D comes in the 18-lead side-brazed cavity DIP.

The following typical application illustrates adjusting of the reference to a desired value, and proper grounding for accurate operation, and avoiding oscillations.

### Typical Applications

0V to 5V Bar Graph Meter



Note 1: Grounding method is typical of all uses. The 2.2  $\mu F$  capacitor is needed if leads to the LED supply are 6" or longer.

Note 2: Supply voltage ( $V^+$  at pin 2) is recommended to be 1.8V above high signal (pin 5) and 1.5V above Reference V (pin 7) for correct operation at  $25^{\circ}C$ .

$$\text{Ref Out } V = 1.25 \left( 1 + \frac{R2}{R1} \right)$$

$$I_{LED} \approx \frac{12.5}{R1}$$



## LM3915 Dot/Bar Display Driver

### General Description

The LM3915 is a monolithic integrated circuit that senses analog voltage levels and drives ten LEDs, LCDs or vacuum fluorescent displays, providing a logarithmic 3 dB/step analog display. One pin changes the display from a bar graph to a moving dot display. LED current drive is regulated and programmable, eliminating the need for current limiting resistors. The whole display system can operate from a single supply as low as 3V or as high as 25V.

The IC contains an adjustable voltage reference and an accurate ten-step voltage divider. The high-impedance input buffer accepts signals down to ground and up to within 1.5V of the positive supply. Further, it needs no protection against inputs of  $\pm 35V$ . The input buffer drives 10 individual comparators referenced to the precision divider. Accuracy is typically better than 1 dB.

The LM3915's 3 dB/step display is suited for signals with wide dynamic range, such as audio level, power, light intensity or vibration. Audio applications include average or peak level indicators, power meters and RF signal strength meters. Replacing conventional meters with an LED bar graph results in a faster responding, more rugged display with high visibility that retains the ease of interpretation of an analog display.

The LM3915 is extremely easy to apply. A 12V full-scale meter requires only one resistor in addition to the ten LEDs. One more resistor programs the full-scale anywhere from 1.2V to 12V independent of supply voltage. LED brightness is easily controlled with a single pot.

The LM3915 is very versatile. The outputs can drive LCDs, vacuum fluorescents and incandescent bulbs as well as LEDs of any color. Multiple devices can be cascaded for a dot or bar mode display with a range of 60 or 90 dB. LM3915s can also be cascaded with LM3914s for a linear/log display or with LM3916s for an extended-range VU meter.

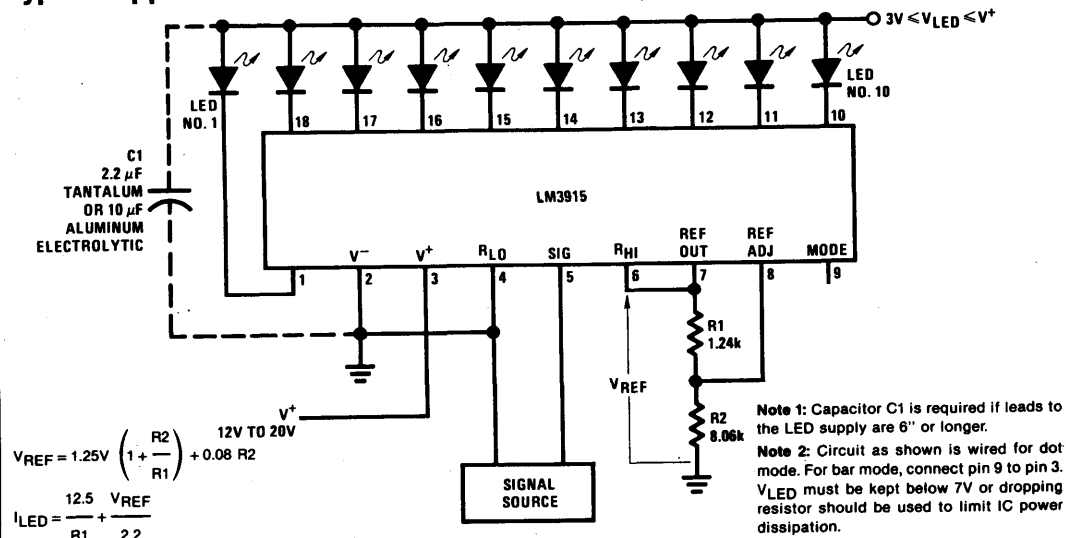
### Features

- 3 dB/step, 30 dB range
- Drives LEDs, LCDs, or vacuum fluorescents
- Bar or dot display mode externally selectable by user
- Expandable to displays of 90 dB
- Internal voltage reference from 1.2V to 12V
- Operates with single supply of 3V to 25V
- Inputs operate down to ground
- Output current programmable from 1 mA to 30 mA
- Input withstands  $\pm 35V$  without damage or false outputs
- Outputs are current regulated, open collectors
- Directly drives TTL or CMOS
- The internal 10-step divider is floating and can be referenced to a wide range of voltages

The LM3915 is rated for operation from  $0^{\circ}C$  to  $+70^{\circ}C$ . The LM3915N is available in an 18-lead molded DIP package and the LM3915J comes in the 18-lead ceramic DIP.

### Typical Applications

#### 0V to 10V Log Display





## MM5421, MM5422 Digital Alarm Clocks

### General Description

The MM5421, MM5422 digital alarm clock radio chips are monolithic MOS integrated circuits utilizing N-channel, low threshold, enhancement mode and ion-implanted depletion mode devices.

Each circuit contains all the logic necessary for a digital clock with sleep and alarm control and is intended for clock-radio applications.

Real time and alarm time are displayed in hours-minutes and sleep time is displayed in minutes when setting the sleep counter.

An alarm output is provided that "beeps" a ~15% duty cycle, 700 Hz signal gated at 2 Hz rate when the alarm set time and the real time matches. A sleep output that provides a DC level is used to control the radio. It is activated with the alarm output or programmed via the sleep counter to turn OFF from 0 to 59 minutes after the sleep counter is set.

A snooze feature is provided for a 9-minute recurrence of the alarm after it has sounded.

Setting is done via the standard fast and slow set buttons when in the time set, alarm set or sleep set modes. These control inputs are TRI-STATE® inputs to reduce pin count.

The 50/60 Hz clock selects what segment data is on the outputs, i.e., a duplex LED display interface.

The MM5421, MM5422 are bonded in a 22-pin package. The MM5422 has a 24-hour/50 Hz option and the MM5421 has the 12-hour/50 Hz or 12-hour/60 Hz options.

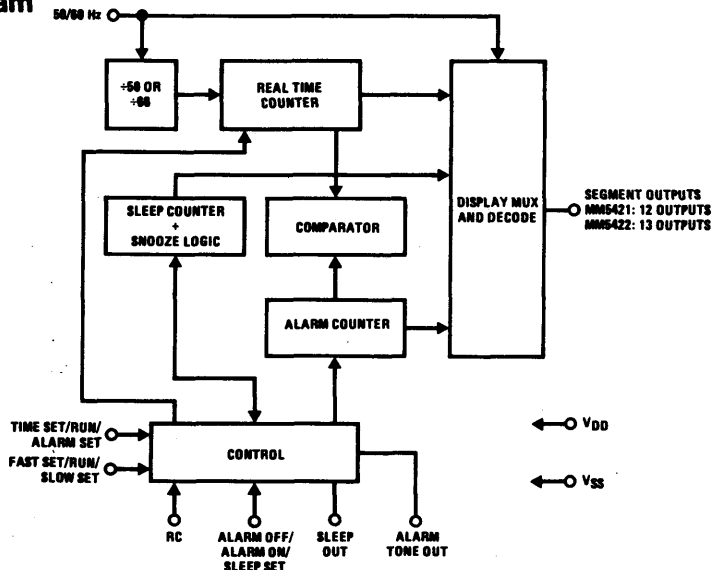
### Features

- Duplex LED display drive
- Fast/slow set capability
- 24-hour alarm
- "Snooze" function (9 minutes)
- On-chip alarm oscillator
- Alarm tone output gated at a 2 Hz rate
- Power fail indication—entire display flashes at a 1 Hz rate
- Automatic power-on reset
- PM display indicator
- Presetable 59 minute sleep timer

### Applications

- Alarm clocks
- Desk clocks
- Clock radios
- Automobile clocks
- Stopwatches
- Industrial clocks
- Portable clocks
- Timers

### Block Diagram





# MM5450, MM5451 LED Display Drivers

## General Description

The MM5450 and MM5451 are monolithic MOS integrated circuits utilizing N-channel metal gate low threshold, enhancement mode and ion-implanted depletion mode devices. They are available in 40-pin molded or cavity dual-in-line packages. Each output can sink up to 15 mA at 1.0V maximum output voltage. A single pin controls the LED display brightness by setting a reference current through a variable resistor connected to VDD.

- Enable (on MM5450)
- Wide power supply operation
- TTL compatibility
- 34 or 35 outputs, 15 mA sink capability
- Alphanumeric capability
- Pin compatible to the MM5452, MM5453 LCD drivers

## Features

- Continuous brightness control
- Serial data input
- No load signal required

## Applications

- COPs or microprocessor displays
- Industrial control indicator
- Relay driver
- Digital clock, thermometer, counter, voltmeter
- Instrumentation readouts

## Block Diagram

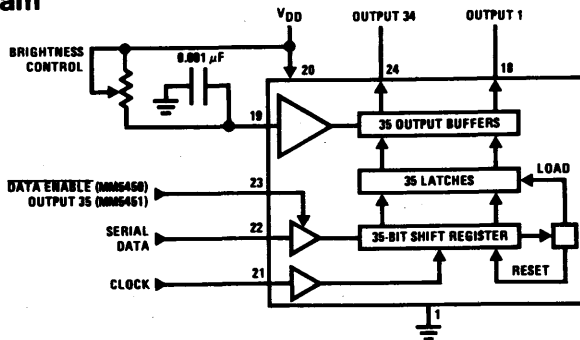
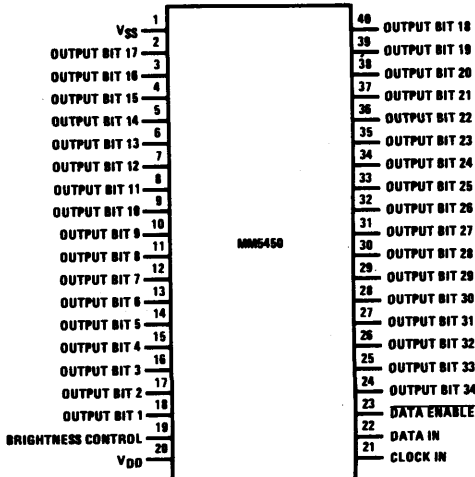
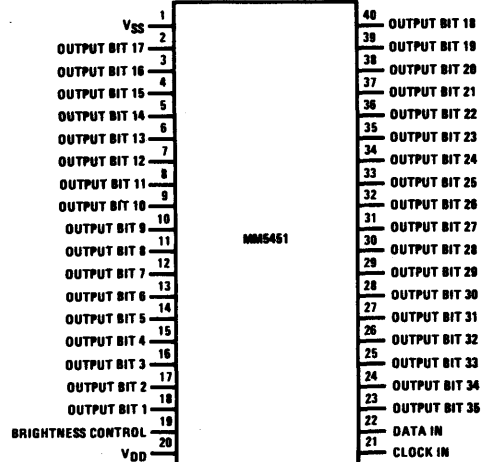


FIGURE 1

## Connection Diagrams (Dual-In-Line Packages)



TOP VIEW  
FIGURE 2a



TOP VIEW  
FIGURE 2b



## MM5455 Digital Alarm Clock

### General Description

The MM5455 digital alarm clock radio chip is a monolithic MOS integrated circuit utilizing N-channel, low threshold, enhancement mode and ion-implanted depletion mode devices.

The MM5455 contains all the logic necessary for a digital clock with sleep and alarm control and is intended for clock-radio applications.

Real time and alarm time are displayed in hours-minutes and sleep time is displayed in minutes when setting the sleep counter.

An alarm output is provided that "beeps" a 700 Hz tone gated by 2 Hz rate when the alarm set time and the real time matches. A sleep output that provides a DC level is used to control the radio. It is activated with the alarm output or programmed via the sleep counter to turn OFF from 0 to 59 minutes after the sleep counter is set.

A snooze feature is provided for a 9-minute recurrence of the alarm after it has sounded. Setting is done via the standard fast and slow set buttons when in the time set, alarm set or sleep set modes. These control inputs are TRI-STATE® inputs to reduce pin count.

The 50/60 Hz clock selects what segment data is on the outputs, i.e. a duplex LED display interface.

The MM5455 is bonded in a 24-pin package and is capable of 24-hour/50 Hz, 12-hour/60 Hz and 12-hour/50 Hz operations.

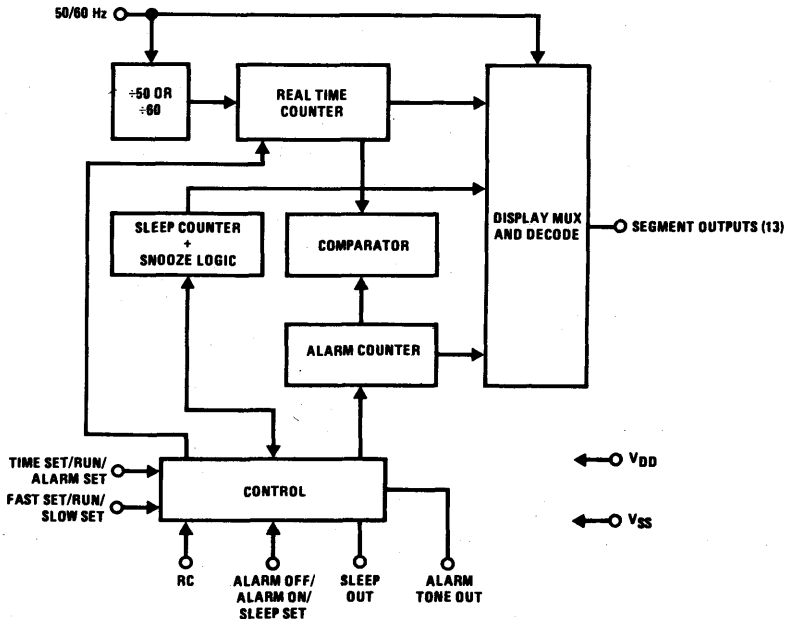
### Features

- Duplex LED display drive
- Fast/slow set capability
- 24-hour alarm
- "Snooze" function (9 minutes)
- On-chip alarm oscillator
- Alarm tone output gated at a 2 Hz rate
- Power fail indication—entire display flashes at a 1 Hz rate
- Automatic power-on reset
- PM display indicator
- Presetable 59 minute sleep timer

### Applications

- Alarm clocks
- Desk clocks
- Clock radios
- Automobile clocks
- Stopwatches
- Industrial clocks
- Portable clocks
- Timers

### Block Diagram







## MM5456, MM5457 Digital Alarm Clocks

### General Description

The MM5456, MM5457 digital alarm clock radio chips are monolithic MOS integrated circuits utilizing N-channel, low threshold, enhancement mode and ion-implanted depletion mode devices.

Each circuit contains all the logic necessary for a digital clock with sleep and alarm control and is intended for clock-radio applications.

Real time and alarm time are displayed in hours-minutes and sleep time is displayed in minutes when setting the sleep counter.

An alarm output is provided that "beeps" a 50% duty cycle, 700 Hz signal gated at 2 Hz rate when the alarm set time and the real time matches. A sleep output that provides a DC level is used to control the radio. It is activated with the alarm output or programmed via the sleep counter to turn OFF from 0 to 59 minutes after the sleep counter is set.

A snooze feature is provided for a 9-minute recurrence of the alarm after it has sounded.

Setting is done via the standard fast and slow set buttons when in the time set, alarm set or sleep set modes. These control inputs are TRI-STATE® inputs to reduce pin count.

The 50/60 Hz clock selects what segment data is on the outputs, i.e., a duplex LED display interface.

The MM5456, MM5457 are bonded in a 22-pin package. The MM5457 has a 24-hour/50 Hz option and the MM5456 has the 12-hour/50 Hz or 12-hour/60 Hz options.

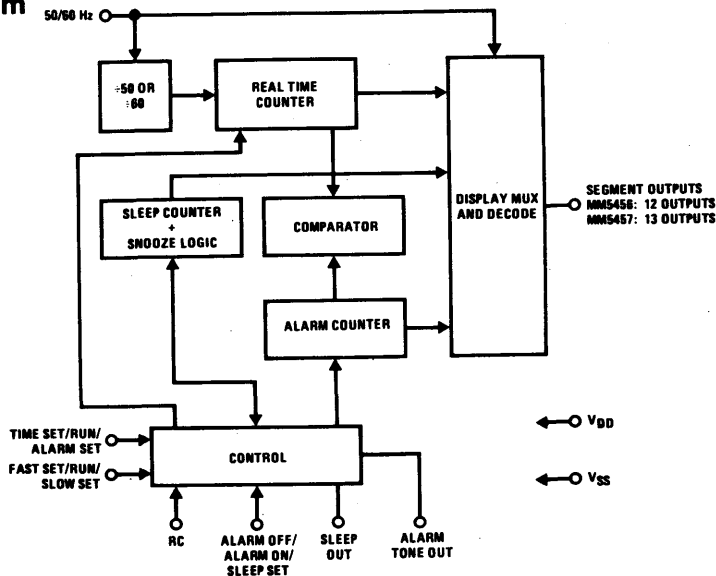
### Features

- Duplex LED display drive
- Fast/slow set capability
- 24-hour alarm
- "Snooze" function (9 minutes)
- On-chip alarm oscillator
- Alarm tone output gated at a 2 Hz rate
- Power fail indication—entire display flashes at a 1 Hz rate
- Automatic power-on reset
- PM display indicator
- Presetable 59 minute sleep timer

### Applications

- Alarm clocks
- Desk clocks
- Clock radios
- Automobile clocks
- Stopwatches
- Industrial clocks
- Portable clocks
- Timers

### Block Diagram





# MM54C48/MM74C48 BCD-to-7 Segment Decoder

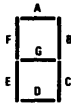
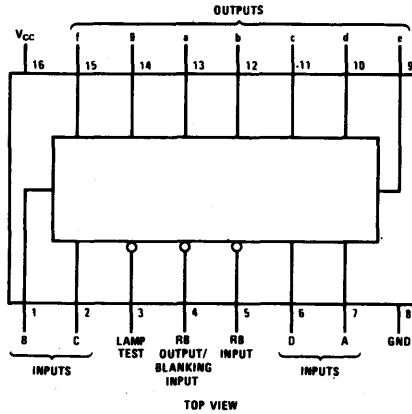
## General Description

The MM54C48/MM74C48 BCD-to-7 segment decoder is a monolithic complementary MOS (CMOS) integrated circuit constructed with N- and P-channel enhancement transistors. Seven NAND gates and one driver are connected in pairs to make binary-coded decimal (BCD) data and its complement available to the seven decoding AND-OR-INVERT gates. The remaining NAND gate and three input buffers provide test blanking input/ripple-blanking output, and ripple-blanking inputs.

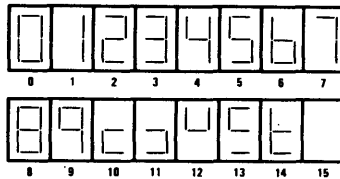
## Features

- Wide supply voltage range 3.0V to 15V
- Guaranteed noise margin 1.0V
- High noise immunity 0.45 V<sub>CC</sub> typ
- Low power fan out of 2
- TTL compatibility driving 74L
- High current sourcing output (up to 50 mA)
- Ripple blanking for leading or trailing zeros (optional)
- Lamp test provision

## Connection Diagram



Segment Identification



Numerical Designations and Resultant Displays

**MM54C901/MM74C901 Hex Inverting TTL Buffer**  
**MM54C902/MM74C902 Hex Non-Inverting TTL Buffer**  
**MM54C903/MM74C903 Hex Inverting CMOS Buffer**  
**MM54C904/MM74C904 Hex Non-Inverting CMOS Buffer**

**General Description**

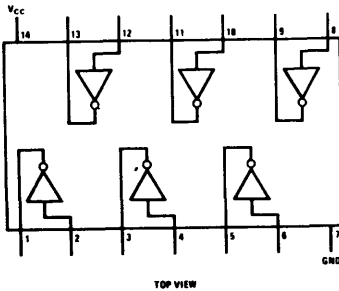
These hex buffers employ complementary MOS to achieve wide supply operating range, low power consumption, high noise immunity. These buffers provide direct interface from PMOS into CMOS or TTL and direct interface from CMOS to TTL or CMOS operating at a reduced  $V_{CC}$  supply. For specific applications see MOS Brief 18 in the back of this catalog.

**Features**

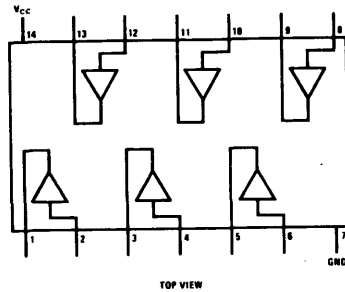
- Wide supply voltage range            3.0V to 15V
- Guaranteed noise margin                1.0V
- High noise immunity                    0.45  $V_{CC}$  typ
- TTL compatibility                        fan out of 2 driving standard TTL

**Connection and Logic Diagrams**

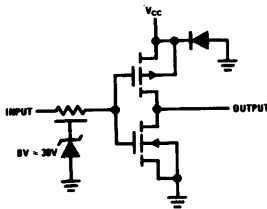
**MM54C901/MM74C901**  
**MM54C903/MM74C903**



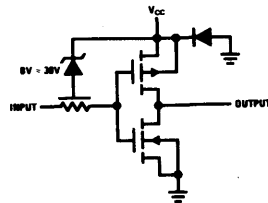
**MM54C902/MM74C902**  
**MM54C904/MM74C904**



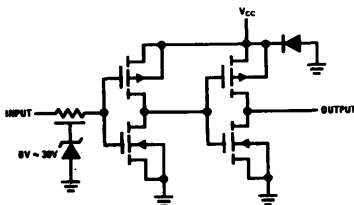
**MM54C901/MM74C901**  
**CMOS to TTL Inverting Buffer**



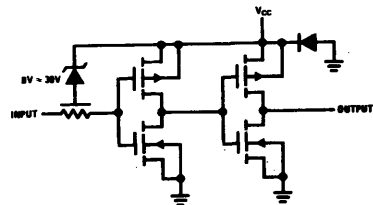
**MM54C903/MM74C903**  
**PMOS to TTL or CMOS Inverting Buffer**



**MM54C902/MM74C902**  
**CMOS to TTL Buffer**



**MM54C904/MM74C904**  
**PMOS to TTL or CMOS Buffer**



**MM54C901/MM74C901, MM54C902/MM74C902,  
 MM54C903/MM74C903, MM54C904/MM74C904**

## Notes

## Notes

## Notes

## Notes

**National Semiconductor Corporation**

2900 Semiconductor Drive  
Santa Clara, California 95051  
Tel: (408) 737-5000  
TWX: (910) 339-9240

**National Semiconductor**

District Sales Office  
345 Wilson Avenue, Suite 404  
Downsview, Ontario M3H 5W1  
Canada  
Tel: (416) 635-7260

**Mexicana de Electronica**

Industrial S.A.  
Tlacoquemecatl No 139-401  
Esquina Adolfo Prieto  
Mexico 12, D.F.  
Tel: 575-78-68, 575-79-24

**NS Electronics Do Brasil**

Avda Brigadeiro Faria Lima 844  
11 Andar Conjunto 1104  
Jardim Paulistano  
Sao Paulo, Brasil  
Telex: 1121008 CABINE SAO PAULO

**National Semiconductor GmbH**

Eisenheimerstrasse 61-II  
8000 München 21  
West Germany  
Tel: (089) 576091  
Telex: 05-22772

**National Semiconductor (UK) Ltd.**

301 Harpur Centre  
Horne Lane  
Bedford MK40 1TR  
United Kingdom  
Tel: 0234-47147  
Telex: 826 209

**National Semiconductor**

789 Ave. Houba de Strooper  
1020 Bruxelles  
Belgium  
Tel: (02) 4783400  
Telex: 61007

**National Semiconductor Ltd.**

Vodroffsvej 44  
1900 Copenhagen V  
Denmark  
Tel: (01) 356533  
Telex: 15179

**National Semiconductor France**

Expansion 10000  
28, rue de la Redoute  
92 260 Fontenay aux Roses  
France  
Tel: 660 81 40  
Telex: NSF250956

**National Semiconductor SRL**

Via Alberto Mario 26  
20149 Milano  
Italy  
Tel: (02) 469 28 64/469 24 31  
Telex: 332835

**National Semiconductor Sweden**

Algrytevagen 23  
S-127 32 Skarholmen  
Sweden  
Tel: (8) 970835  
Telex: 10731

**NS International Inc., Japan**

Miyake Building  
1-9 Yotsuya, Shinjuku-ku 160  
Tokyo, Japan  
Tel: (04) 355-5711  
TWX: 232-2015 JSCJ-J

**National Semiconductor (Hong Kong) Ltd.**

8th Floor,  
Cheung Kong Electronic Bldg.  
4 Hing Yip Street  
Kwun Tong  
Kowloon, Hong Kong  
Tel: 3-899235  
Telex: 73866 NSEHK HX  
Cable: NATSEMI

**NS Electronics Pty. Ltd.**

Cnr Stud Rd. & Mtn. Highway  
Bayswater, Victoria 3153  
Australia  
Tel: 03-729-6333  
Telex: 32096

**National Semiconductor (Pty.) Ltd.**

No. 1100 Lower Delta Road  
Singapore 3  
Tel: 2700011  
Telex: NAT SEMI RS 21402

**National Semiconductor (Taiwan) Ltd.**

3rd Floor, Apollo Bldg.,  
No. 218-7 Chung Shiao E. Road,  
Sec 4, Taipei, Taiwan  
P.O. Box 68-332 Taipei  
Tel: 7310393-4, 7310465-6  
Telex: 22837 NSTW  
Cable: NSTW Taipei

**National Semiconductor (Hong Kong) Ltd.**

Korea Liaison Office  
6th Floor, Kunwon Bldg.  
1-2 Mookjung-Dong  
Choong-Ku, Seoul  
C.P.O. Box 7941 Seoul  
Tel: 267-9473  
Telex: K24942